

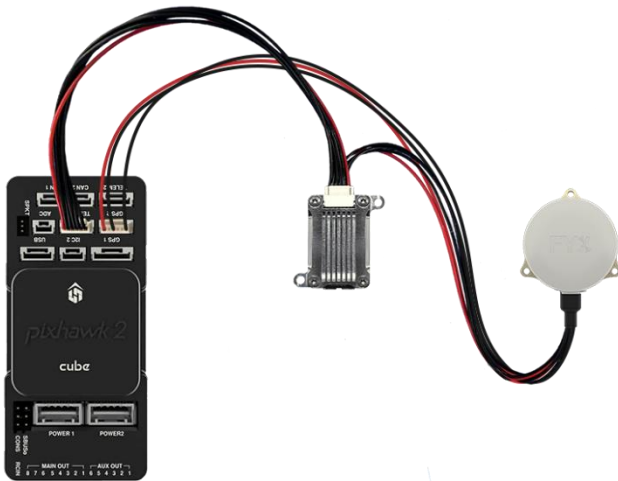

microLink

User and Installation Guide



UAV-1003064-001 Rev O



© 2021 – 2023 uAvionix Corporation. All rights reserved.

uAvionix Corporation
300 Pine Needle Lane
Bigfork, MT 59911

<http://www.uavionix.com>

support@uavionix.com

Except as expressly provided herein, no part of this guide may be reproduced, transmitted, disseminated, downloaded or stored in any storage medium, for any purpose without the express written permission of uAvionix. uAvionix grants permissions to download a single copy of this guide onto an electronic storage medium to be viewed for personal use, provided that the complete text of this copyright notice is retained. Unauthorized commercial distribution of this manual or any revision hereto is strictly prohibited.

uAvionix® and Ping® are registered trademarks of uAvionix Corporation, and may not be used without express permission of uAvionix.

1 Revision History

Revision	Date	Comments
A	6/23/2019	Initial release
B	07/17/2019	Modified the FCC and added the IC regulatory statement
C	08/09/2019	Updated the skyStation statistics definitions and modified for uav files updating
D	08/12/2019	Updated the FCC and IC statements per the TCB
E	08/28/2019	Updated the RF exposure limits per the TCB
F	12/18/2019	Added Updating instructions for skyStation and microLink radios
G	7/21/2020	Updated configuration item descriptions. Updated firmware upgrade instructions.
H	10/27/2020	Add Transmit and Receive Masking configuration instructions.
I	1/25/2021	Quick Start and Here2 appendices moved to separate documents. Updated screen captures. Added remote configuration instructions.
J	5/15/2021	Corrected USER connector pin-out table. Updated skyLinkApp and web page screenshots.
K	07/12/2021	Updated images for skyStation 2.
M	9/7/2021	New integration image with Pixhawk and ardupilot parameters. All updated instructions and images for using radio ID link.
N	9/20/2021	Update integration instructions for Pixhawk with new GPS connection and dual GPS connection.
O	3/27/2023	Specify compatible browsers. Update specifications.

2 Limited Warranty

uAvionix products are warranted to be free from defects in material and workmanship for one year from purchase. For the duration of the warranty period, uAvionix, at its sole option, will repair or replace any product which fails under normal use. Such repairs or replacement will be made at no charge to the customer for parts or labor, provided that the customer shall be responsible for any transportation cost.

This warranty does not apply to cosmetic damage, consumable parts, damage caused by accident, abuse, misuse, water, fire or flood, damage caused by unauthorized servicing, or product that has been modified or altered.

IN NO EVENT, SHALL UAVIONIX BE LIABLE FOR ANY INCIDENTAL, SPECIAL, INDIRECT OR CONSEQUENTIAL DAMAGES, WHETHER RESULTING FROM THE USE, MISUSE OR INABILITY TO USE THE PRODUCT OR FROM DEFECTS IN THE PRODUCT. SOME STATES DO NOT ALLOW THE EXCLUSION OF INCIDENTAL OR CONSEQUENTIAL DAMAGES, SO THE ABOVE LIMITATIONS MAY NOT APPLY TO YOU.

Warranty Service

Warranty repair service shall be provided directly by uAvionix.

3 Contents

1	Revision History	3
2	Limited Warranty	4
3	Contents	5
4	Introduction	7
5	Specification	8
5.1	microLink Radio Technology	8
5.2	Regulatory Statements	9
5.2.1	FCC Statement	9
5.2.2	Industry Canada Statement	9
5.3	Ground Radio System (GRS) – skyStation	10
5.4	Airborne Radio System (ARS)	11
5.5	Typical System Configuration	12
5.6	Mechanical Specifications	13
6	Configuration	15
6.1	MicroLink	15
6.1.1	Wiring	15
6.1.2	Mission Planner Configuration	16
6.2	skyStation	18
6.3	Connection to the POE Network	19
6.4	skyStation Start-up and Connection	20
6.4.1	Run skyLinkApp.exe	20
6.4.2	Configure Hop Table	21
6.4.3	Verify Link	22
6.4.4	Connecting to Mission Planner	22
6.5	skyLinkApp	25
6.5.1	Status Tab	26
6.5.2	Maps Tab	28

6.5.3	Configuration Tab	29
6.6	skyStation Configuration and Health Webpage	32
6.6.1	Firmware Information	34
6.6.2	Configuration Items	34
6.6.3	Status	35
6.6.4	Network Configuration	36
6.6.5	skyStation Firmware Update	37
6.6.6	microLink Radio Firmware Update	39

4 Introduction

microLink is an aviation grade, miniature, Beyond Visual Line Of Sight (BVLOS) data link radio specifically designed for long range, robust, Unmanned Aircraft Systems (UAS) telemetry data links. Ideal for size, weight, power and performance sensitive applications, microLink operates in the 902-928MHz license-free ISM band.

5 Specification

5.1 microLink Radio Technology

- Dual radio architecture for true diversity
 - Path (spatial) diversity
 - Frequency diversity
 - Polarization gain
- Dynamic Medium and Multiple access, time and position synchronized, to support 100s of simultaneous links
 - Adaptive time and frequency spreading
- Global Positioning System (GPS) Coordinated Universal Time (UTC) link synchronization
- Status, integrity and health monitoring
- Environmental RTCA/DO-160G
- Software RTCA/DO-178C Level C
- Complex Hardware RTCA/DO-254 Level C
- FCC 47 CFR Part 15.247 ID 2AFFTC2XISM

Radio Specifications	
Band	902-928MHz ISM Band
Architecture	Dual Diversity Radios
Transmit Power	1W (4W EIRP)
Spreading	Code and Frequency
Bandwidth	200kHz
Receiver Sensitivity	
User Receiver	-118dBm
Control Receiver	-121dBm
Doppler Capture Range	±16kHz

5.2 Regulatory Statements

5.2.1 FCC Statement

FCC ID: 2AFFTC2XISM

This device meets the FCC requirements for RF exposure in public or uncontrolled environments.

Changes or modifications not expressly approved by the party responsible for compliance could void the user's authority to operate the equipment

This device complies with part 15 of the FCC Rules. Operation is subject to the following two conditions: (1) This device may not cause harmful interference, and (2) this device must accept any interference received, including interference that may cause undesired operation.

5.2.2 Industry Canada Statement

IC ID: 25261-C2XISM

In order to comply with FCC / ISED RF Exposure requirements, this device must be installed to provide at least 20 cm separation from the human body at all times.

Afin de se conformer aux exigences d'exposition RF FCC / ISED, cet appareil doit être installé pour fournir au moins 20 cm de séparation du corps humain en tout temps.

This device complies with Industry Canada's licence-exempt RSSs. Operation is subject to the following two conditions:

- (1) This device may not cause interference; and
- (2) This device must accept any interference, including interference that may cause undesired operation of the device.

Le présent appareil est conforme aux CNR d'Industrie Canada applicables aux appareils radio exempts de licence. L'exploitation est autorisée aux deux conditions suivantes :

- 1) l'appareil ne doit pas produire de brouillage;
- 2) l'appareil doit accepter tout brouillage radioélectrique subi, même si le brouillage est susceptible d'en compromettre le fonctionnement."

5.3 Ground Radio System (GRS) – skyStation

Specification	Value
Input Power	POE 13W Peak
Size	122x82x60mm
Weight	500 grams
Operating Temp	-45 to 70°C
Interfaces	
User	
Protocol	TCP
Control	
Protocol	TCP
Timing/Position	
Position	Internal
Environmental	
DO-160G	Temperature Cat B2



- All-Weather Network-Ready microLink GRS
- TCP Power Over Ethernet (POE) connectivity.
- IP67 grade enclosure.
- Dual Dipole Antennas
- Pole Mounting Kit

5.4 Airborne Radio System (ARS)

- Protocol agnostic autopilot telemetry interface
- Dual MMCX antenna connectors
- Supports NMEA/UBX GPS Sensors such as HERE2 and microFYX



USER Interface (top connector)

Pi n	Typ e	Physica l	Port
1	5V	5V	
2	RXD	IN	TELEM
3	TXD	OUT	TELEM
4	RFU		
5	RFU		
6	GND		

Timing/Position, CTRL Interface (bottom connector)

Pi n	Typ e	Physica l	Port
1	5V	5V	
2	RXD	IN	GPS
3	UTC	IN	1PPS
4	RXD	IN	Control
5	TXD	OUT	Control
6	GND		

The USER interface is the data connection to the auto pilot. The Control interface is for changing settings like frequency hop tables, serial port parameters, etc.

5.5 Typical System Configuration

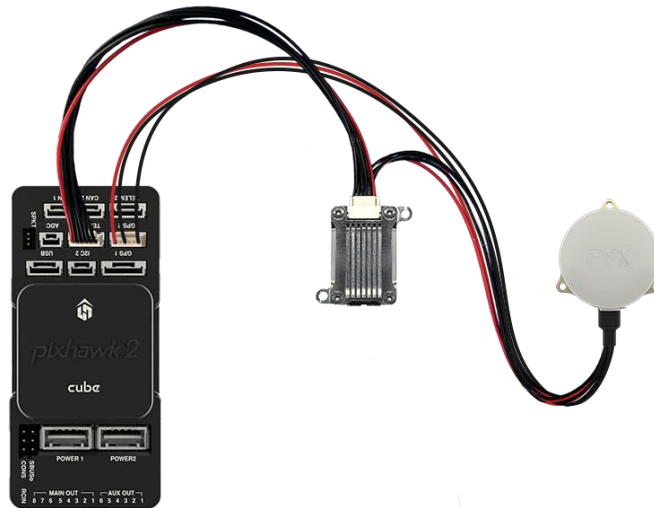
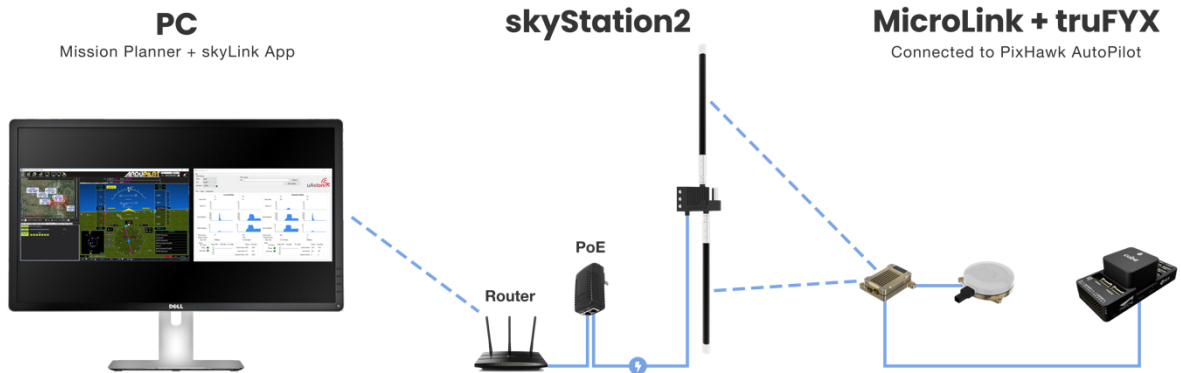

Ordering Part Numbers	
skyStation 2	UAV-1005539-001
microLink	UAV-1002868-001
GPS Options	
microFYX kit	UAV-1002500-001
HERE2 kit	UAV-1002956-001
Replacement Parts	
MMCX 100mm	UAV-1003063-001
MMCX 200mm	UAV-1003063-002
GH 6p Cable	UAV-1003061001
GH 8p Cable	UAV-1003062-001

5.6 Mechanical Specifications

Airborne Radio System (ARS)

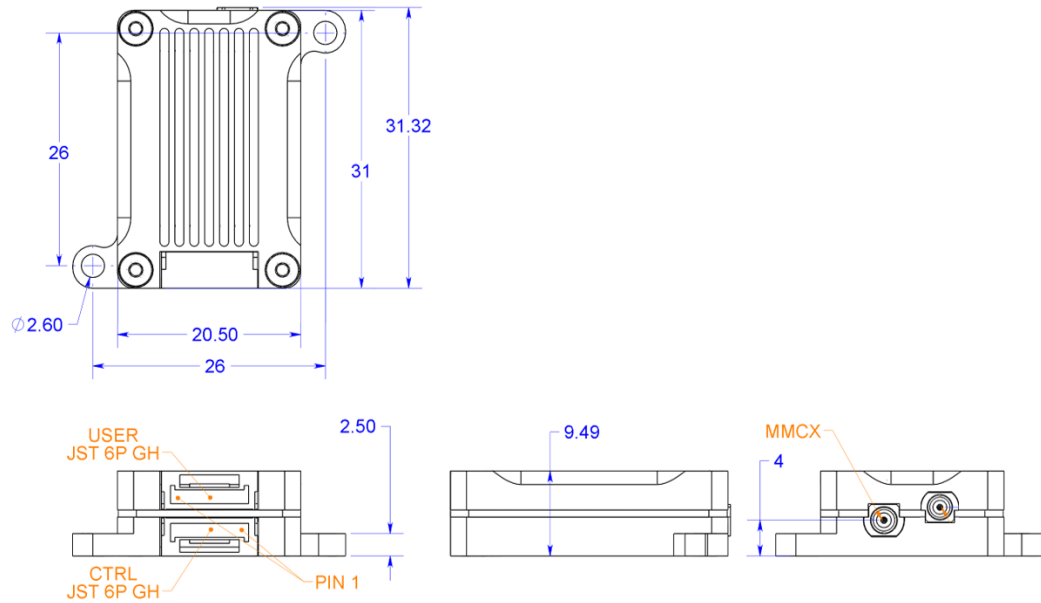

Ground Radio System (GRS) – skyStation

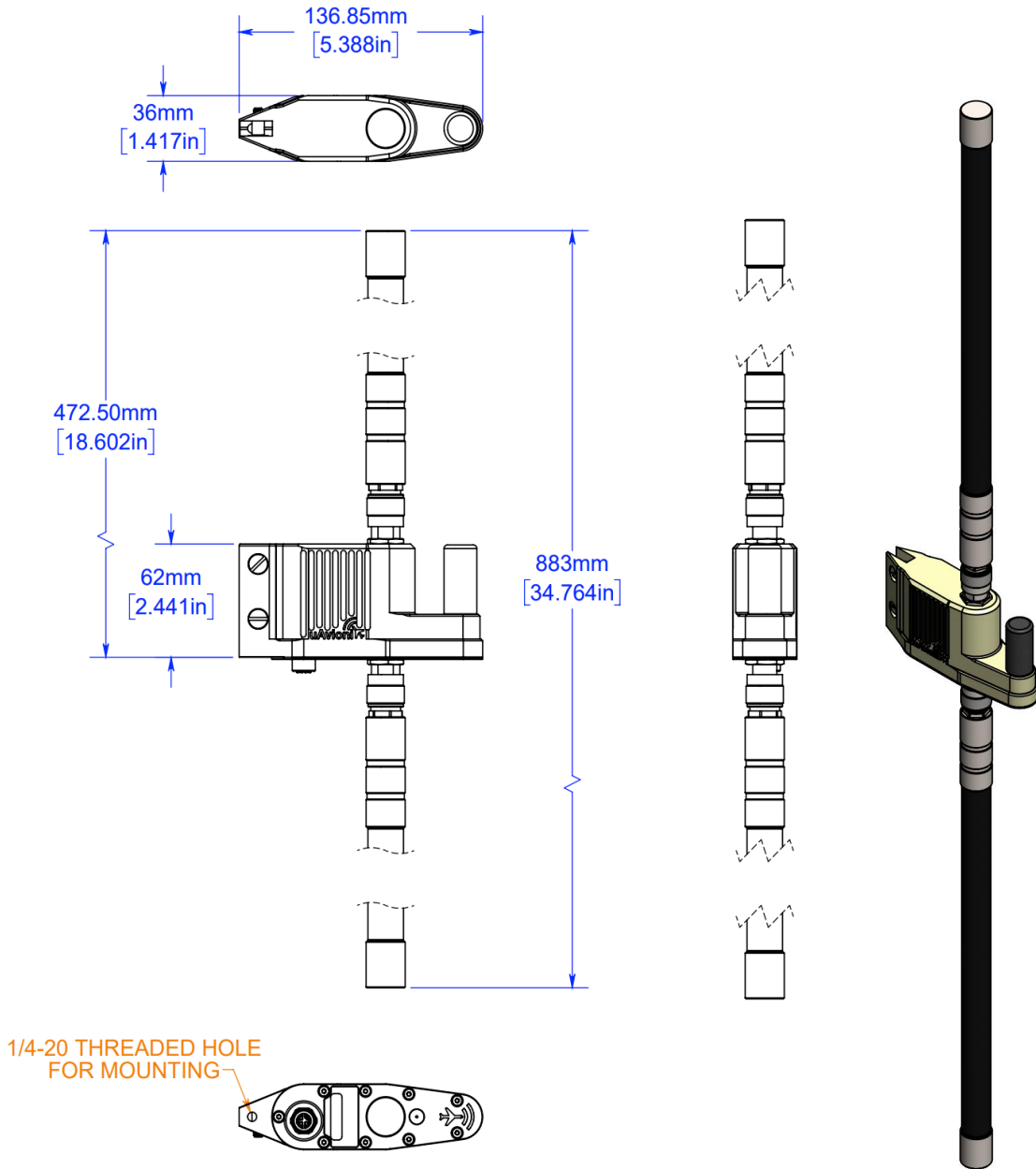

6 Configuration

6.1 MicroLink

Connect the microLink ARS to an available telemetry point on the Pixhawk Autopilot. The microFYX provides GPS and PPS to both the microLink and the Pixhawk through the GPS 2 port (serial 4).

6.1.1 Wiring

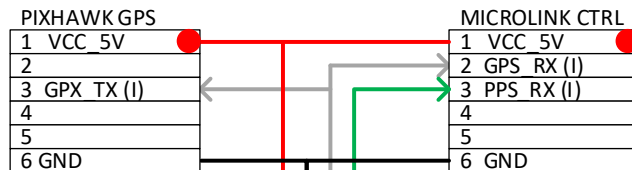
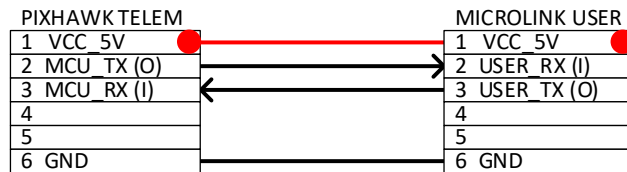

6.1.2 Mission Planner Configuration

The following parameters need to be configured in Mission Planner when using microLink. The serial port depends on which telemetry port the microLink is connected to. For this instance, microLink is connected to Telem1

Function	Parameter	Value	Description
microLink C2 Control	SERIAL 1::BAUD	57	Baud rate = 57600
	SERIAL 1::PROTOCOL	1	Protocol type Mavlink

The following parameters need to be configured in mission planner when using the microFYX as the primary GPS on GPS 2 (serial 4)

Function	Parameter	Value	Description
GPS	GPS_AUTO_CONFIG	2 *	Enable GPS Auto Config
	GPS_SAVE_CONFIG	2*	Enable GPS Save Config
	GPS_TYPE	5	GPS = NMEA
	SERIAL4_BAUD	115	Baud Rate = 115200
	SERIAL4_PROTOCOL	5	Serial 4 = GPS
	BRD_SAFETYENABLE	0	Disable Safety Switch
	SERIAL3_BAUD	57	Baud Rate = 57600
	SERIAL3_PROTOCOL	1	MAVLINK 1

The following parameters need to be configured in Mission Planner when using the microFYX and Here2 GPS in a dual GPS configuration. microFYX is on GPS 2 (serial 4) and the Here2 GPS is on GPS 1 (serial 3).

Function	Parameter	Value	Description
GPS	GPS_AUTO_CONFIG	2 *	Enable GPS Auto Config
	GPS_SAVE_CONFIG	2*	Enable GPS Save Config
	GPS_TYPE	1	GPS = AUTO (Here 2)
	GPS_TYPE2	5	GPS = NMEA (microFYX)
	SERIAL3_BAUD	38	Baud = 38400 (Here 2)
	SERIAL3_PROTOCOL	5	Serial 3 = GPS (Here 2)
	SERIAL4_BAUD	115	Baud Rate = 115200 (microFYX)
	SERIAL4_PROTOCOL	5	Serial 4 = GPS (microFYX)
	BRD_SAFETYENABLE	0	Disable Safety Switch

6.2 skyStation

Connect skyStation to a POE switch or POE power injector.

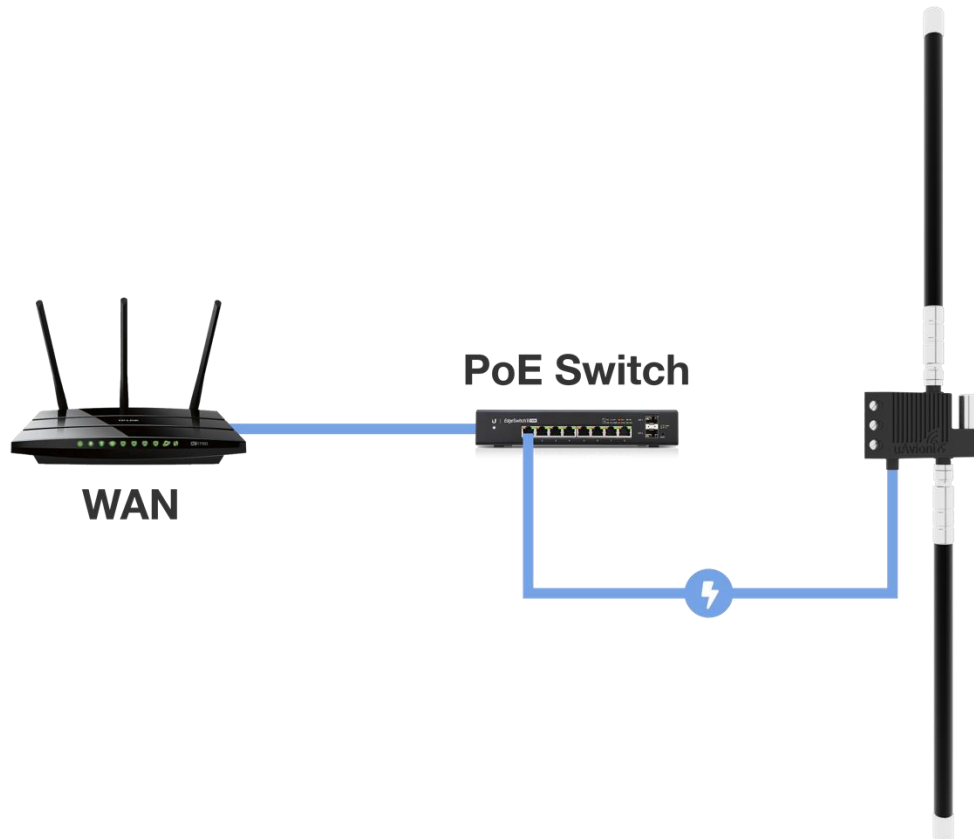

6.3 Connection to the POE Network

The skyStation connects to a network via POE using an M12 X-Coded connector.

POE Specifications:

Parameter	Value
Standard	803.3af (802.3at Type1)
Maximum power	15.4W
Voltage Range	37 – 57V
Maximum Current	350mA
Maximum Cable Resistance	20Ω
Supported Cabling	Shielded Cat 3, Shielded Cat 5 and Shielded Cat 6
Supported Modes	Mode A (endspan), Mode B (midspan)
Power Management	Power Class 0
Maximum Cable Length	100 meters

M12 plug

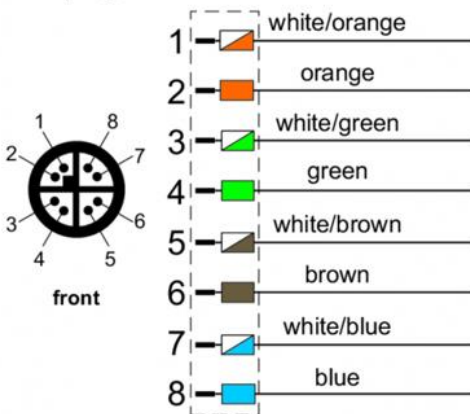

M12 jack

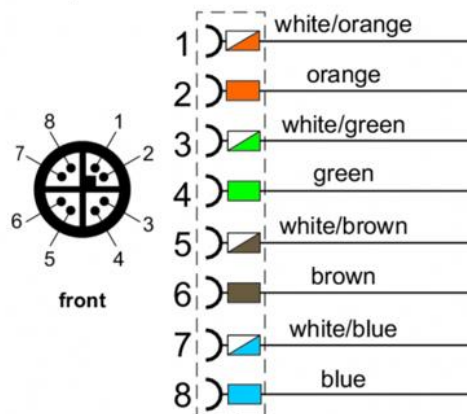

Caution!

Absolute maximum DC voltage +57 V. A higher DC voltage value will permanently damage the equipment!

UAV-1003064-001 Rev O

6.4 skyStation Start-up and Connection

Connect the skyStation to a POE capable network switch. At power-up an IP address will be assigned to the skyStation by the local DHCP server. By default, the skyStation will accept TCP connections for User channel information on TCP port 42430 and the Control channel information on port 42431. An IP Scan can be used to find the IP address of the skyStation. MAC addresses are printed on the skyStation label.

See section 6.6.4 for configuring the network settings on skyStation.

6.4.1 Run skyLinkApp.exe

Included in your document and software package is SkyLinkApp. Run the skyLinkApp.exe, configure the Mode Settings to TCP, enter the IP address of the skyStation, and enter the default Control port 42431. The Status box in the upper left-hand corner will turn green indicating a successful connection to the skyStation.

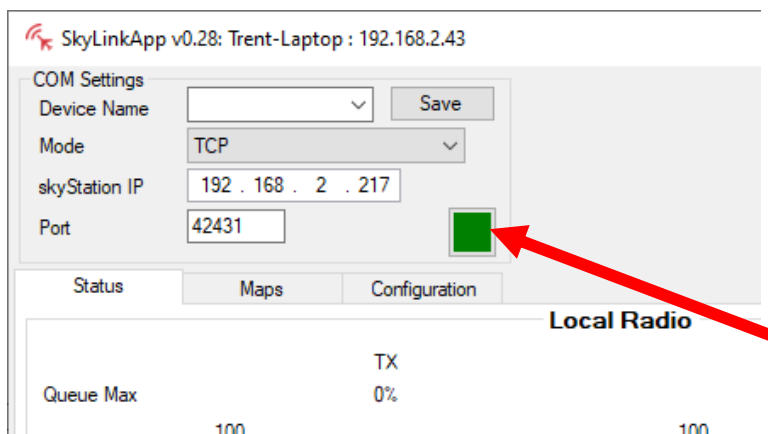

NOTE: If you are not able to connect to the skyStation it is likely your firewall is blocking access on port 42431. Please setup your firewall to allow skyLinkApp.exe TCP access on port 42431.

Please see section 6.6.4 to change or view the network configuration settings on the skyStation. See section 6.5 for more details on the skyLinkApp.

6.4.2 Configure Hop Table

Once connected via the SkyLinkApp, go to the Configuration tab.

At first power up the user may need to configure the Hop Table to link with the microLink. On the label on the back of the microLink is a Radio ID.

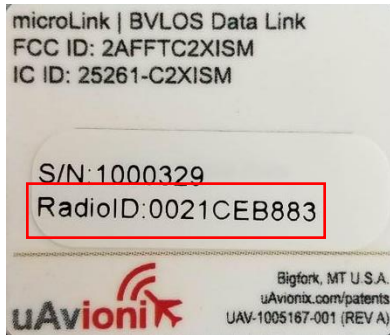

- Enter the Radio ID into the “Radio ID Input” field on the SkyLinkApp.
- Press the “Generate “Radio ID Hop Table” button
- Press “Save Hop Table To Radio”

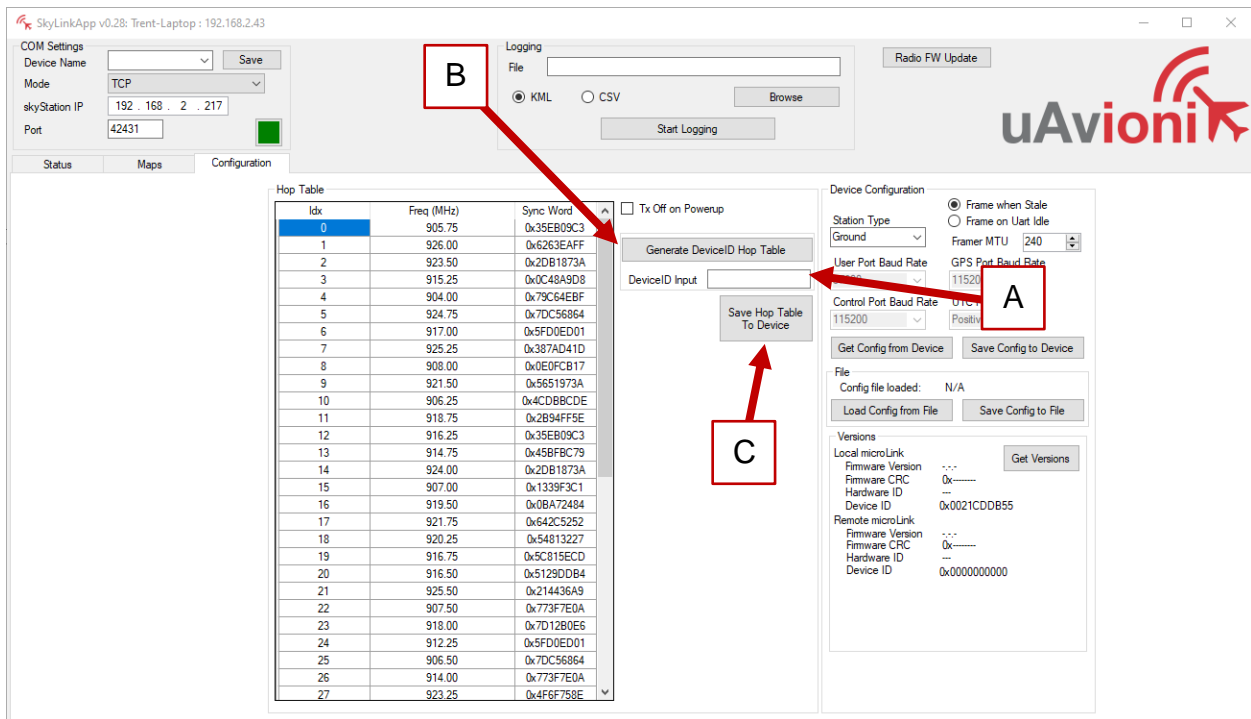

The skyStation and microLink now share the same unique Hop Table.

6.4.3 Verify Link

To verify link go to the Status Tab of the skyLinkApp. When the data arrives, skyLinkApp will begin graphing the radio link statistics.

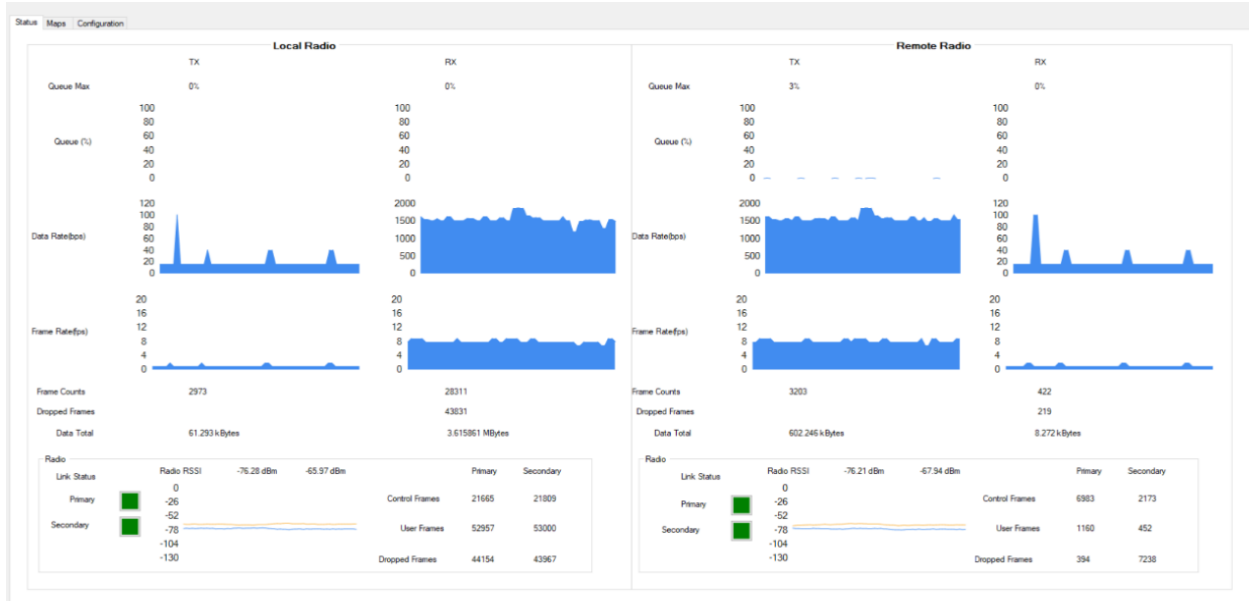

6.4.4 Connecting to Mission Planner

Download and install Mission Planner from:

<http://firmware.ardupilot.org/Tools/MissionPlanner/>

<http://ardupilot.org/planner/docs/mission-planner-installation.html>

Verify that the flight controller and skyStation are powered and running and that skyLinkApp.exe is receiving data. Run Mission Planner and select the communications drop down menu.

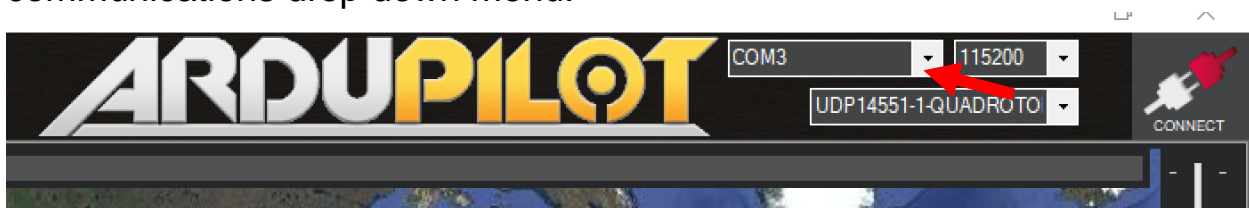

Select TCP as the communication mode and hit the Connect button on the upper right-hand corner.

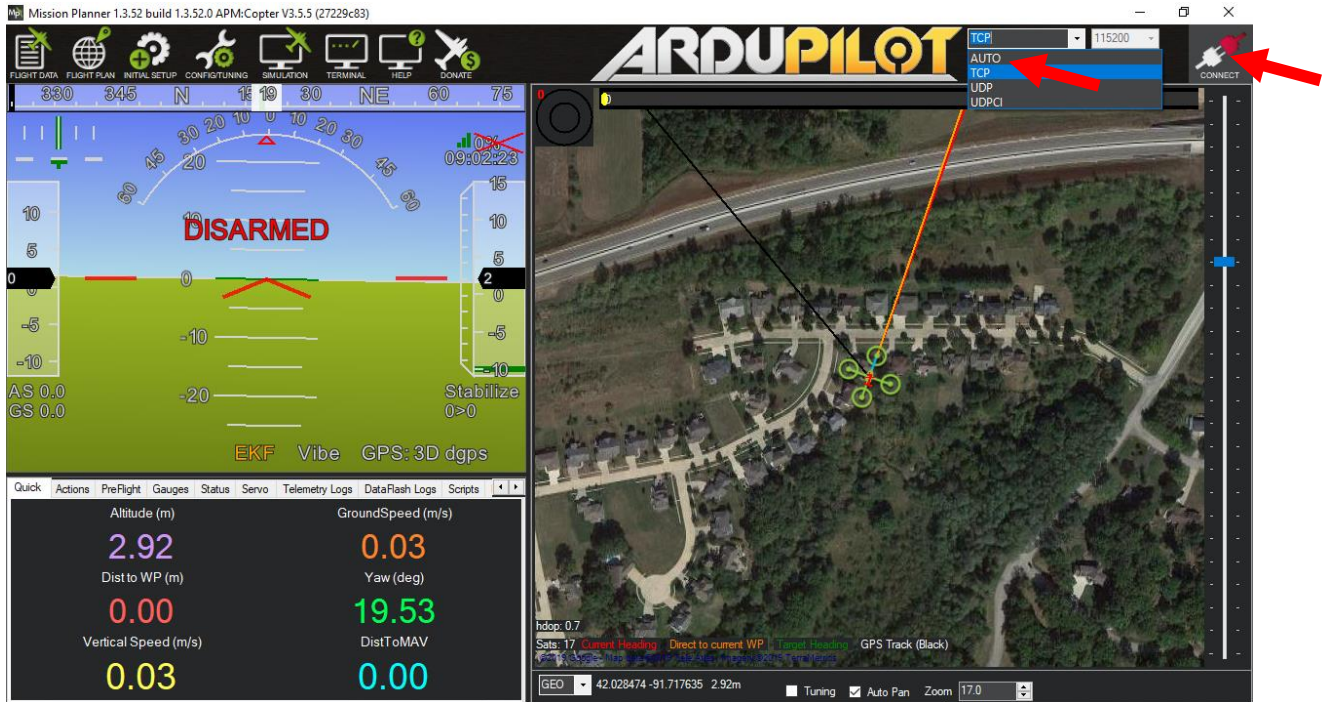

Enter the skyStation IP address as found earlier in skyLinkApp.exe and click OK.

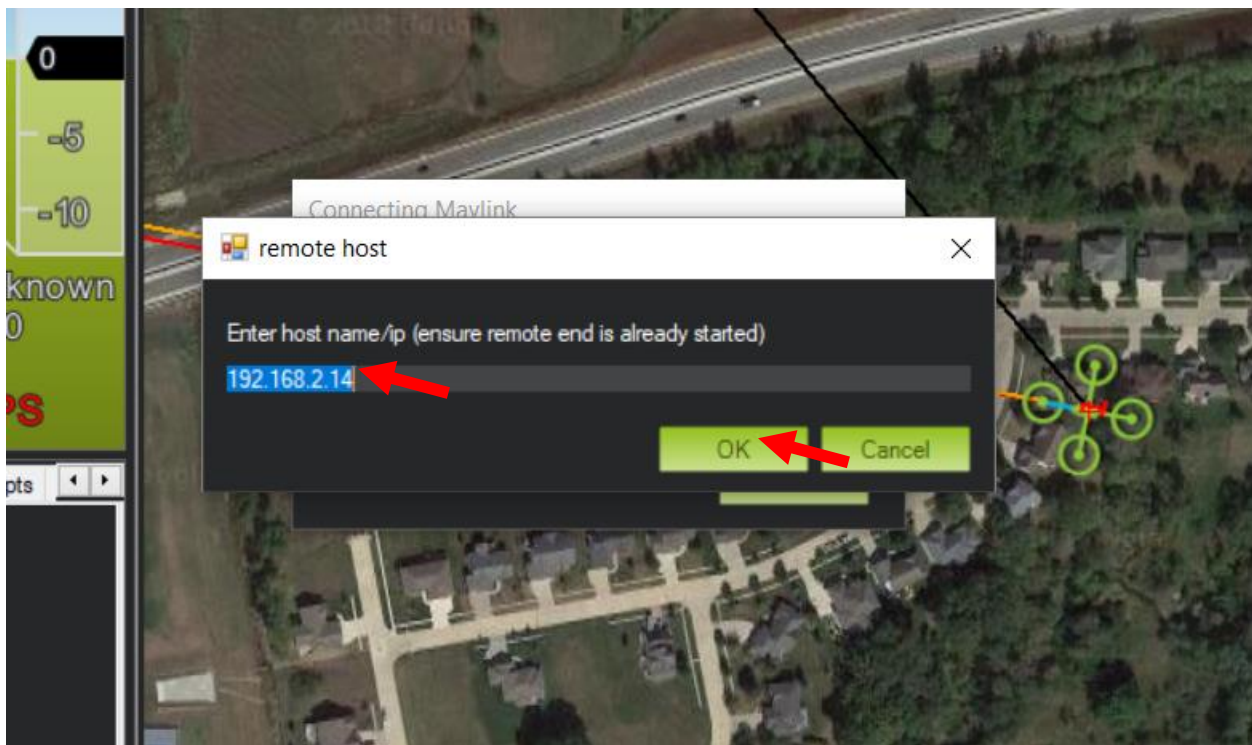

Enter port 42430 which is the skyStation default TCP port for Mission Planner and click OK.

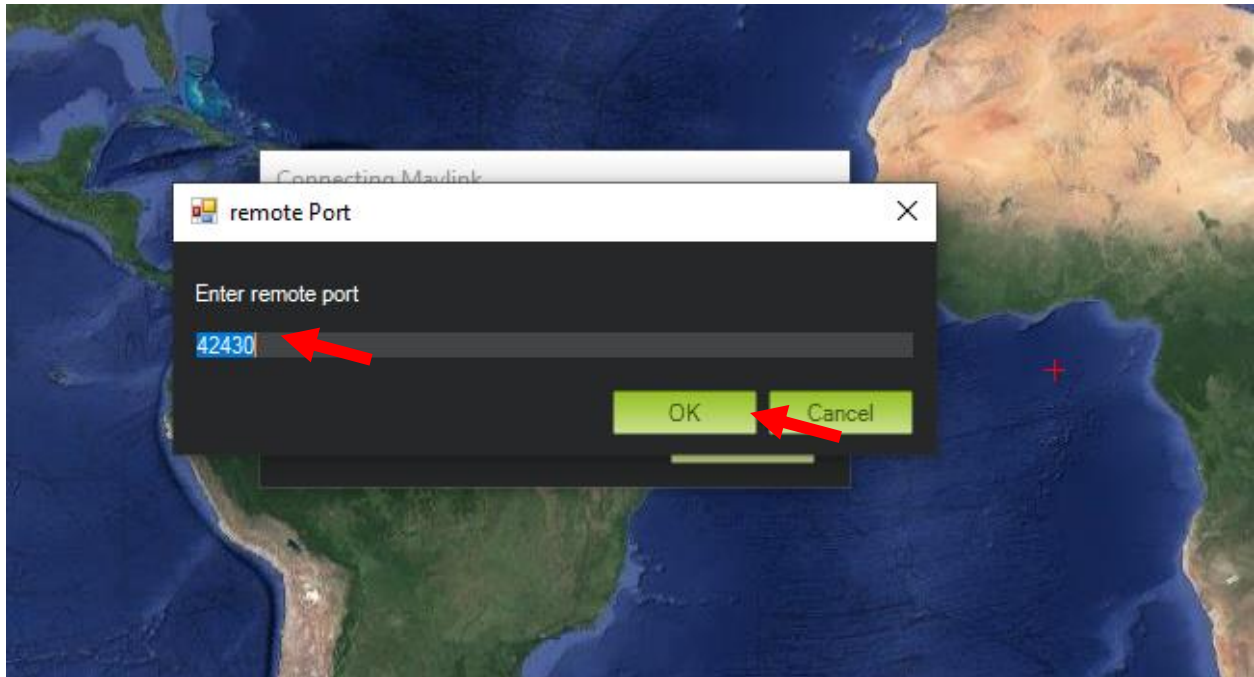

The TCP connection will now take off and you will see the system retrieving parameters as follows for the flight controller.

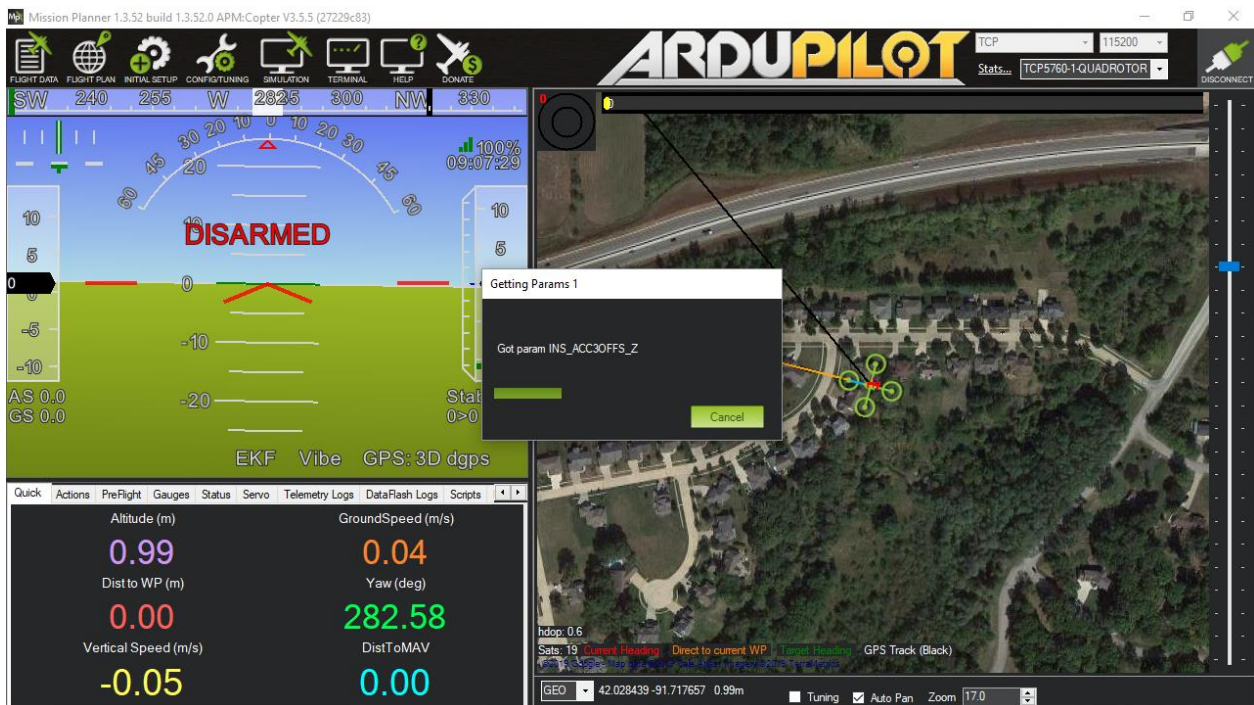

The skyStation is now in place and ready to host missions.

6.5 skyLinkApp

skyLinkApp.exe is the uAvionix Control channel monitoring application used for showing Status, Maps, and Configuration information. It can be connected to the skyStation in TCP mode and the ports are configurable for network flexibility. The port selection must match the skyStation Configuration page setup and the IP address is always the IP address of the skyStation.

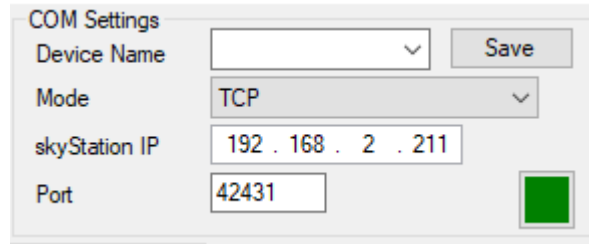

The Device Name field allows the user to enter a name for a set of connection parameters and save them for easy switching between radio connections. Just type in a name and press Save.

There is also a KML logging feature for importation into mapping software. Logging may also be captured in comma separated value (CSV) format.

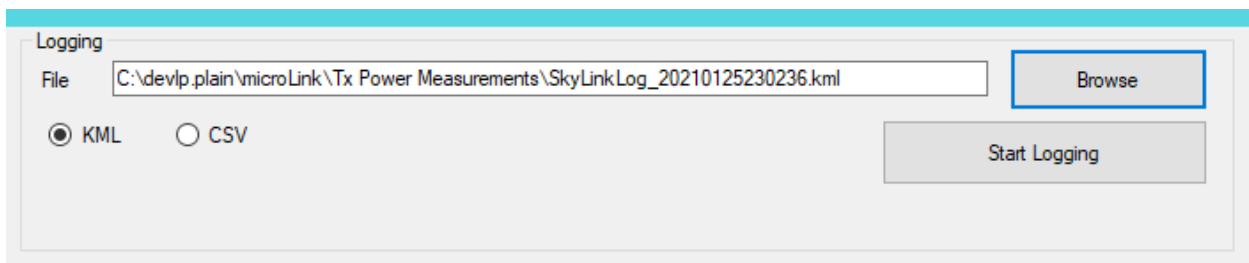

6.5.1 Status Tab

The status data is shown for both the local and the remote radios. It contains both transmit and receive information for the local and remote radios. This information includes memory queue depth information, transmit and receive data rates, frame rates, dropped frames and data totals. It also shows the RSSI's on the primary and secondary radios for both the local and remote radios giving the user comprehensive information on the state of the system.

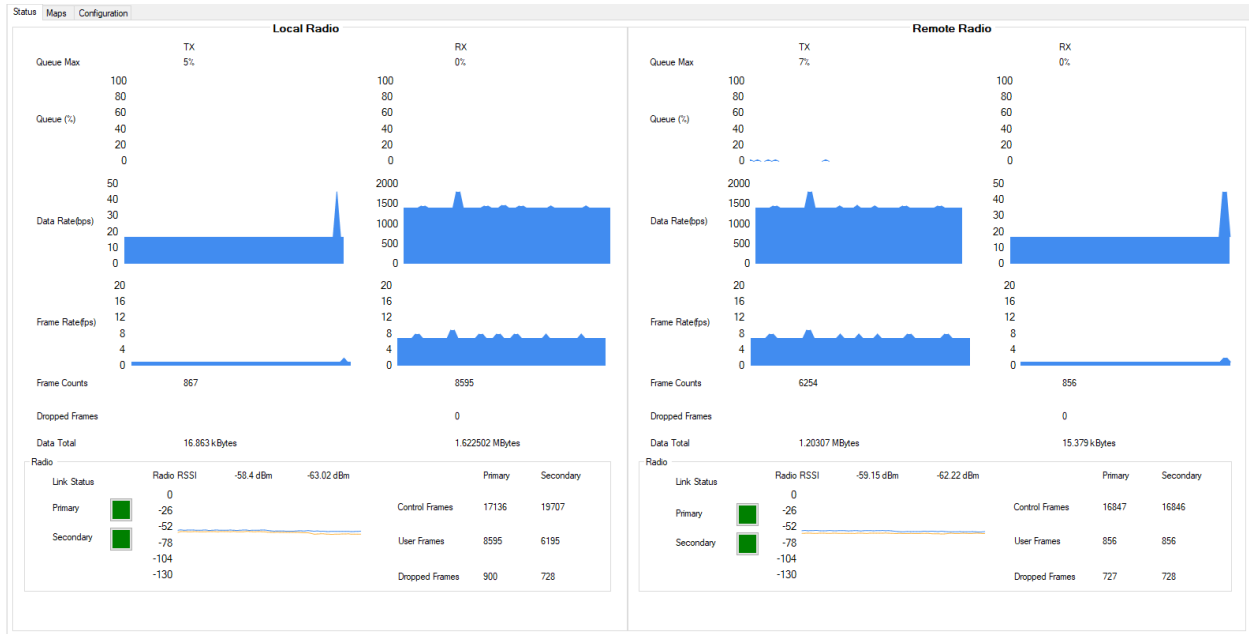

Radio throughput and statistics detail shown below.



RSSI detail shown below.

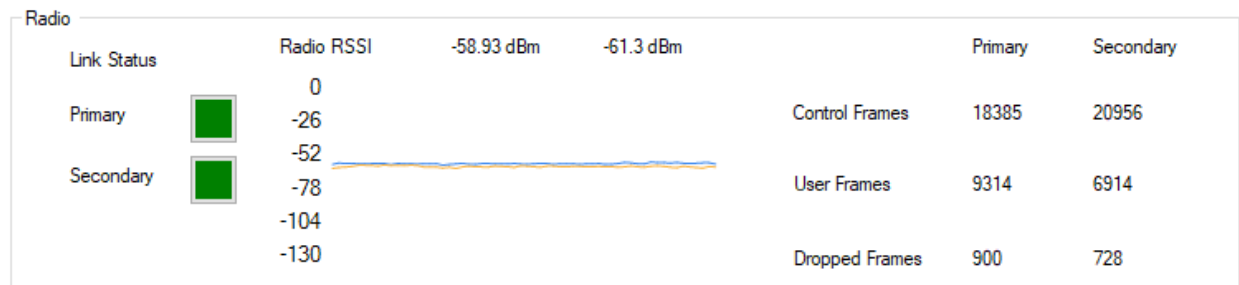

6.5.2 Maps Tab

skyLinkApp.exe has a mapping tab for mapping the local radio skyStation radio as well as the remote aircraft radio. It includes latitude, longitude, altitude, GPS fix type, Slant Range and SV count.

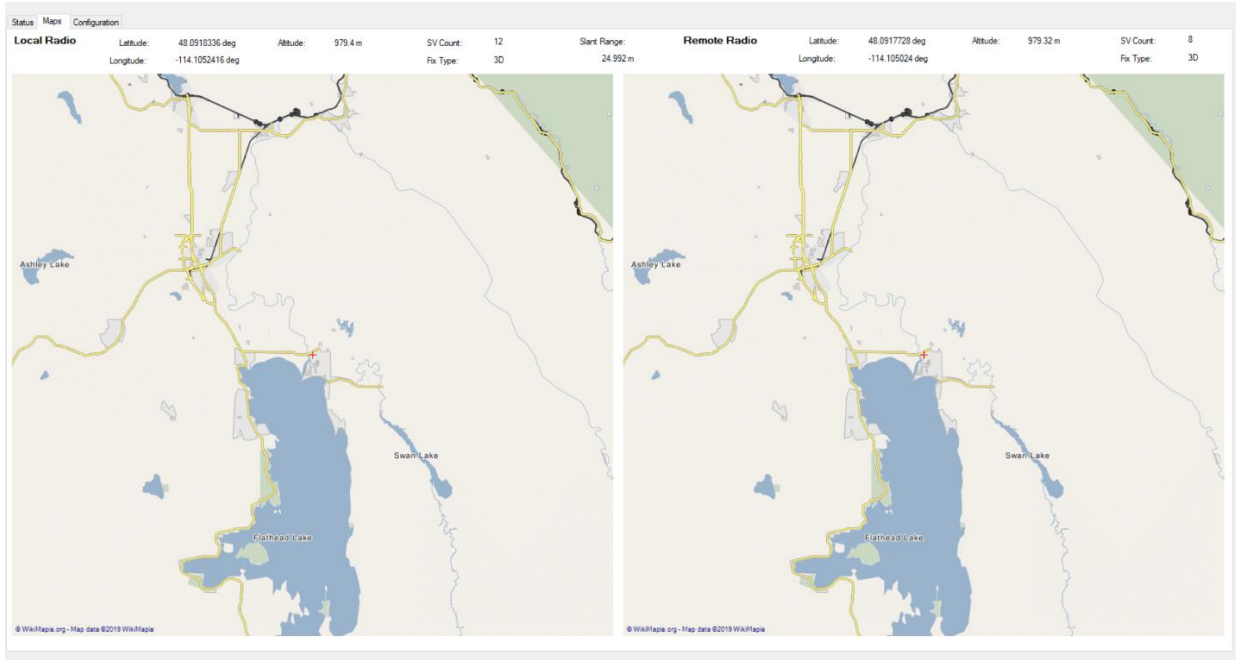

6.5.3 Configuration Tab

skyLinkApp.exe also contains a Configuration page. This page is used for device settings and setup as well as selecting the hop table scheme for the system.

COM Settings

Device Name: [] Save

Mode: TCP

skyStation IP: 192.168.2.217

Port: 42431

Logging

File: []

KML CSV

Browse

Start Logging

Radio FW Update

uAvioni

Status Maps Configuration

Hop Table

Idx	Freq (MHz)	Sync Word
0	905.75	0x35EB09C3
1	926.00	0x6263EAFB
2	923.50	0x2DB1873A
3	915.25	0x0C48A9D8
4	904.00	0x79C64EBF
5	924.75	0x7DC56864
6	917.00	0x5FD0ED01
7	925.25	0x387AD41D
8	908.00	0x0E0FCB17
9	921.50	0x5651973A
10	906.25	0x4CDBBCDE
11	918.75	0x2B94FF5E
12	916.25	0x35EB09C3
13	914.75	0x45BFBC79
14	924.00	0x2DB1873A
15	907.00	0x1339F3C1
16	919.50	0x0BA72494
17	921.75	0x642C5252
18	920.25	0x54813227
19	916.75	0x5C815ECD
20	916.50	0x5129DB4
21	925.50	0x214436A9
22	907.50	0x773F7E0A
23	918.00	0x7D1260E6
24	912.25	0x5FD0ED01
25	906.50	0x7DC56864
26	914.00	0x773F7E0A
27	923.25	0x4F6F758E

Tx Off on Powerup

Generate DeviceID Hop Table

DeviceID Input: 0021CEBF15

Save Hop Table To Device

Device Configuration

Frame when State Frame on Uart Idle

Station Type: Ground

Framer MTU: 240

User Port Baud Rate: 57600

GPS Port Baud Rate: 115200

Control Port Baud Rate: 115200

UTC Pulse Polarity: Positive

Get Config from Device Save Config to Device

File

Config file loaded: N/A

Load Config from File Save Config to File

Versions

Local microLink

Firmware Version: 1.0.12

Firmware CRC: 0x78C363F9

Hardware ID: 0x38

Device ID: 0x0021CDD855

Get Versions

Remote microLink

Firmware Version: ...

Firmware CRC: 0x---

Hardware ID: --

Device ID: 0x0000000000

Hop Table

Idx	Freq (MHz)	Sync Word
0	905.75	0x35EB09C3
1	926.00	0x6263EAFB
2	923.50	0x2DB1873A
3	915.25	0x0C48A9D8
4	904.00	0x79C64EBF
5	924.75	0x7DC56864
6	917.00	0x5FD0ED01
7	925.25	0x387AD41D
8	908.00	0x0E0FCB17
9	921.50	0x5651973A
10	906.25	0x4CDBBCDE
11	918.75	0x2B94FF5E
12	916.25	0x35EB09C3
13	914.75	0x45BFBC79
14	924.00	0x2DB1873A
15	907.00	0x1339F3C1
16	919.50	0x0BA72484
17	921.75	0x642C5252
18	920.25	0x54813227
19	916.75	0x5C815ECD
20	916.50	0x5129DDB4
21	925.50	0x214436A9
22	907.50	0x773F7E0A
23	918.00	0x7D12B0E6
24	912.25	0x5FD0ED01
25	906.50	0x7DC56864
26	914.00	0x773F7E0A
27	923.25	0x4F6F758E

Tx Off on Powerup

Generate DeviceID Hop Table

DeviceID Input

Save Hop Table To Device

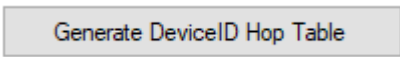
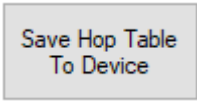
	Generates the Hop Table per the Radio ID input
DeviceID Input <input type="text" value="0021CEBF15"/>	Radio ID input allows the user to enter the airborne radio ID to match Hop Tables.
	Saves the Hop Table currently displayed in the Hop Table window to the device.

Device Configuration

Station Type:

User Port Baud Rate:

Control Port Baud Rate:

Frame when Stale: Frame when Stale

Frame on Uart Idle: Frame on Uart Idle

Framer MTU:

GPS Port Baud Rate:

UTC Pulse Polarity:

The Device Configuration window shows the current device settings for the radio in the skyStation. Clicking the button will pull the configuration parameters currently stored on the device and display them in the window. Clicking the button will push any new configuration parameters to the device.

File

Config file loaded: N/A

The File window allows the user to save or load all the Configuration parameters to a PC.

Versions

Local microLink		<input type="button" value="Get Versions"/>
Firmware Version	1.0.11	
Firmware CRC	0xF1B92857	
Hardware ID	0x38	
Device ID	0x0021CDD855	
Remote microLink		
Firmware Version	---	
Firmware CRC	0x-----	
Hardware ID	---	
Device ID	0x0000000000	

The Versions window shows the microLink radio information for both the Local radio, and the Remote radio when a Link has been made.

6.6 skyStation Configuration and Health Webpage

The skyStation IP address can be determined by accessing the local DHCP server and reviewing the connected devices or by using industry accepted network scanning tools. Directions for each DHCP server, router, or network scanning tool differ. Refer to the instruction manual for these devices or tools to help determine the IP address assigned to the skyStation. The MAC address for each skyStation can be found on the device housing.

The following pages can be viewed in your web browser.

Note nnn.nnn.nnn.nnn is the IP address of the skyStation.

- skyStation base URL:

<http://nnn.nnn.nnn.nnn/>

Displays Health statistics, position and version information. Use to program the target TCP address and Port number.

- skyStation status URL:

<http://nnn.nnn.nnn.nnn/stats>

Displays the status json sentence.

- skyStation update URL:

<http://nnn.nnn.nnn.nnn/update>

Provides ability to update skyStation firmware.

The base URL displays configuration items as well as dynamic skyStation health statistics. The defaults for the User and Control channel connections is shown. All parameters can also be modified to fit your network needs.

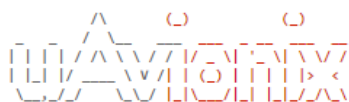

Firmware Information

SkyStation Version: V 0. 0.10 [Update](#)
Radio Version: V1.0.11
Node ID: 0x21CDD855

Settings

Skyline Information

Websocket URL:

Datamux Information

IP Address: (0.0.0.0 for listen)

User Port:

Control Port:

[Network Configuration](#)

Status Information

Name	Value
Up Time	7h:33m:28s
GPS Fix	3
Num GPS Sats	9
Latitude	48.0914496
Longitude	-114.1049344
GPS Altitude	2956
PPS Detected	true
SkyLine Up Time	0s
User Skt Up Time	0s
Ctrl Skt Up Time	37m:3s
Mission Timeout	0

6.6.1 Firmware Information

The skyStation firmware version, microLink radio version and the microLink radio ID associated are displayed here. The user can update the skyStation firmware and microLink radio firmware through the webpage by clicking the “update” link. See section 6.6.5 and 6.6.6.

6.6.2 Configuration Items

Configuration Item	Description
Skyline Websocket URL	When using Skyline or a websocket to manage missions, the mission data will be forwarded through to the URL address entered in this field.
Data Mux IP Address	When this parameter is 0.0.0.0, the skyStation will act as a TCP server and listen for incoming connections. Alternatively, if this address is a valid IP address, the skyStation will act as a TCP client and will attempt to connect to a TCP server listening on [User TCP IP Address : User TCP Port]. 0.0.0.0 is the default setting for this parameter.
Data Mux User Port	This is the port number used for the User connection. Typically, the ground control software uses the User connection to communicate with the aircraft. The skyStation listens on this port and forwards any received TCP datagrams from ethernet to the aircraft. Any User connection data coming from the aircraft will be sent as an ethernet TCP datagram to [User TCP IP Address : User TCP Port].
Data Mux Control Port	This is the port number used for the Control connection. The Control connection is used for device configuration and device monitoring. The skyStation will forward all local data metrics through this port.

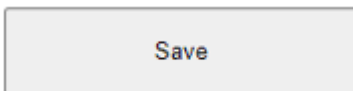

When you modify any configuration item, press the Save button to store the changes. These fields are non-volatile and persist through power cycles.

6.6.3 Status

The Status Information section shows real time statistics updated once every second. It will show skyStation Up Time, GPS and PPS metrics. It will also show SkyLine metrics when connected through to the websocket.

Status Information

Name	Value
Up Time	7h:43m:57s
GPS Fix	3
Num GPS Sats	10
Latitude	48.0914496
Longitude	-114.1049344
GPS Altitude	2957
PPS Detected	true
SkyLine Up Time	0s
User Skt Up Time	0s
Ctrl Skt Up Time	47m:37s
Mission Timeout	0

6.6.4 Network Configuration

Clicking the Network Configuration link on the main landing page will forward you to the Network Configuration page where the user can adjust the network connectivity settings used by the skyStation when a DHCP server is not available.

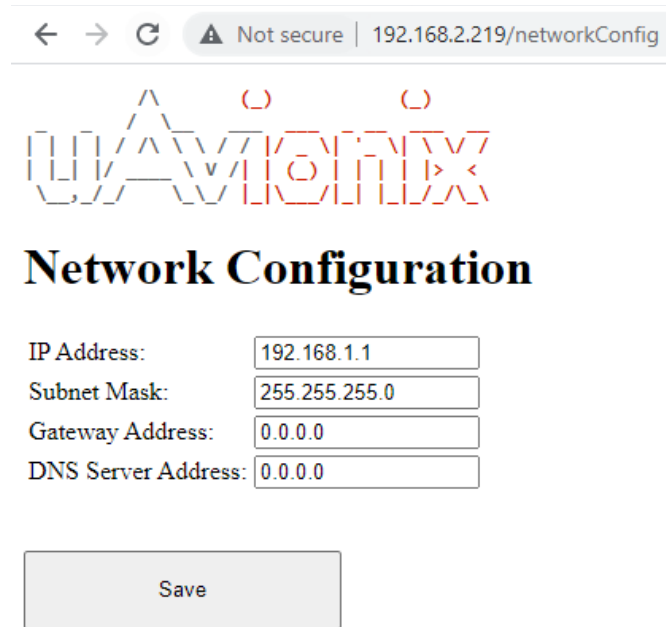

← → ↻ ⚠ Not secure | 192.168.2.219/networkConfig

Network Configuration

IP Address:

Subnet Mask:

Gateway Address:

DNS Server Address:

[Main Page](#)

Configuration Item	Description
IP Address	This is the IP address number of the skyStation which will be used when a DHCP server is not available. The network administrator should assign this number.
Subnet Mask	Mask used with the skyStation IP address to differentiate between local and remote subnet destinations.
Gateway IP Address	Address used to send packets out of the local network.
DNS Address	IP address of the Domain Name Service.

When you modify any configuration item, press the Save button to store the changes. These fields are non-volatile and persist through power cycles.

6.6.5 skyStation Firmware Update

The firmware on the skyStation can be updated through the skyStation Configuration Webpage by clicking the Update link next to the version number. It is recommended updates are performed from a PC using the Chrome, Firefox or Microsoft Edge web browser.



Choose the appropriate file to upload and click Start Update.

DO NOT power off the skyStation or close the web browser until the update is complete.

← → ↻ 192.168.50.80/update?0

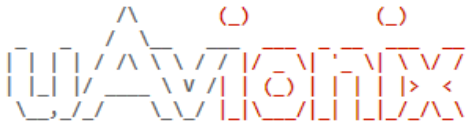

Firmware Update

Rebooting...

Release_UA...c9c558.uav

Target Device:

[Main Page](#)

When the file transfer is complete, click the Main Page link to return to the skyStation Configuration Webpage¹. The version number on the Configuration Webpage should reflect the firmware version uploaded.

¹ The reboot of the skyStation could take up to 45s to complete
UAV-1003064-001 Rev O

6.6.6 microLink Radio Firmware Update

The firmware on the microLink radio can be updated through the skyStation Configuration Webpage by clicking the Update link next to the version number. It is recommended updates are performed from a PC using the Chrome, Firefox or Microsoft Edge web browser.

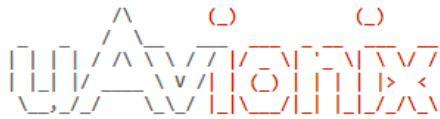
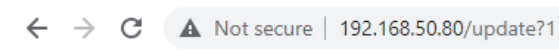

Firmware Update

UAV-10043...7004235.uav

Target Device:

[Main Page](#)

Choose the appropriate file to upload and click Start Update.

DO NOT power off the skyStation or close the web browser until the update is complete.

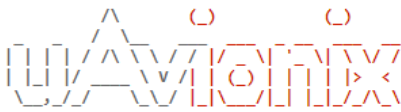

Firmware Update

Rebooting...

Choose File UAV-10043...7004235.uav

Target Device: Radio ▾

Start Update

[Main Page](#)

When the file transfer is complete, click the Main Page link to return to the skyStation Configuration Webpage². The version number on the Configuration Webpage should reflect the firmware version uploaded.

² The reboot of the skyStation could take up to 45s to complete
UAV-1003064-001 Rev O