



AV-30-C

Installation Manual



© 2020 - 2024 uAvionix Corporation. All rights reserved.

uAvionix Corporation

Bigfork, MT

www.uavionix.com

support@uavionix.com

Except as expressly provided herein, no part of this guide may be reproduced, transmitted, disseminated, downloaded, or stored in any storage medium, for any purpose without the express written permission of uAvionix. uAvionix grants permissions to download a single copy of this guide onto an electronic storage medium to be viewed for personal use, provided that the complete text of this copyright notice is retained. Unauthorized commercial distribution of this manual or any revision hereto is strictly prohibited.

uAvionix® and Ping® are registered trademarks of uAvionix Corporation and may not be used without express permission of uAvionix.

AV-30, AV-30-E, AV-30-C, AV-Mag, AV-Link, AV-APA, AV-HSI, BeaconX, tailBeaconX, and skyBeaconX are trademarks of uAvionix Corporation and may not be used without express permission of uAvionix.

Patents www.uavionix.com/patents

1 Revision History

Revision	Date	Comments
A	4/24/2020	Initial release
B	7/13/2020	Added installation log-book entry requirement. Added method to determine proper screw length. Highlighted primary functions. Added items included in the ICA. Added startup time and AoA reference per MOPS requirement. Added reference to CFR 23.1321.
C	8/10/2020	Added reference to AoA operation in inverted flight and operation in excess of G limits. Added reference to utilize wire type in accordance with AC 43.13-1B.
D	6/3/2021	Updated Top Level Assembly references.
E	9/2/2021	Software update to 2.1.2 Added Definition of Acronyms & Terms section Added requirement for pitot / static connection Add vibration check to System Checkout
F	12/3/2021	Software update to 2.1.4 Update mounting screw length guidance Add transponder control
G	5/10/2022	Update Installation Limitations Update battery guidance Update trim guidance Update mislabeled note on DG wiring diagram
H	9/29/2022	Software update to 2.1.5 Add display of bootloader version number. Add BeaconX Ground Test Mode
I	2/15/2023	Add SAE AS8013A to Table 2 - Applicable Performance Standards Add Serial 4 to Serial Inputs Add AV-Mag optional equipment description Add AV-Mag to pinout diagram Add AV-Mag wire color coding table Add AV-Mag installation and calibration Add display of AV-Mag software part number and software version number Add Pitot zero-point field calibration Add Multi-point altitude field calibration Change pitch trim limits to +-27 degrees

		<p>Add additional fields to Table 13 Installation Menu Setting</p> <p>“MAG CAL” flag added to indicate magnetometer calibration needed</p> <p>Add AV-Link and AV-Mag to trademarked terms list</p>
J	5/10/2023	<p>Add AV-Mag parallel operation</p> <p>Add field update pins to wiring and pin diagrams</p> <p>Clarify airspeed and altimeter limitation</p> <p>Describe installation kit contents</p> <p>Add tailBeaconX parallel operation figure</p>
K	8/10/2023	<p>Fix reference and update units on IAS Vspeeds</p>
L	12/18/2023	<p>Update feature matrix</p> <p>Add AV-Link and autopilot optional interfaces</p> <p>Update power and interconnect specifications</p> <p>Update AV-Mag orientation options</p>
M	2/2/2024	<p>Add AV-Link</p> <p>Add extended NiMH Battery Pack</p> <p>Add Appendix A: Example Wiring Schematics</p> <p>Add Angle of Attack to Mandatory Settings</p> <p>Replaced guidance of AC 43.13-1B with ASTM F2639-18</p> <p>Update Wiring diagrams in § 11.7</p> <p>Add Pitot Zero as required during checkout</p> <p>Update Table 13 with new installation options</p>
N	5/2/2024	<p>Add instructions to set AV-Link password</p> <p>Clarify wording around pitot/static interfaces for DG installation</p> <p>Clarified max and min exposed threads for screw lengths in section 11.6</p> <p>Corrected a typo in step 2.f in section 11.6 about the thread engagement calculation</p>

2 Warnings / Disclaimers

All device operational procedures must be learned on the ground.

uAvionix is not liable for damages arising from the use or misuse of this product.

This equipment is classified by the United States Department of Commerce's Bureau of Industry and Security (BIS) as Export Control Classification Number (ECCN) 7A994.

These items are controlled by the U.S. Government and authorized for export only to the country of ultimate destination for use by the ultimate consignee or end-user(s) herein identified. They may not be resold, transferred, or otherwise disposed of, to any other country or to any person other than the authorized ultimate consignee or end-user(s), either in their original form or after being incorporated into other items, without first obtaining approval from the U.S. government or as otherwise authorized by U.S. law and regulations.

3 Limited Warranty

uAvionix products are warranted to be free from defects in material and workmanship for two years from the installation of AV-30-C on the aircraft. For the duration of the warranty period, uAvionix, at its sole option, will repair or replace any product which fails in normal use. Such repairs or replacement will be made at no charge to the customer for parts or labor, provided that the customer shall be responsible for any transportation cost.

Restrictions: This warranty does not apply to cosmetic damage, consumable parts, damage caused by accident, abuse, misuse, fire or flood, theft, damage caused by unauthorized servicing, or product that has been modified or altered.

Disclaimer of Warranty: IN NO EVENT, SHALL UAVIONIX BE LIABLE FOR ANY INCIDENTAL, SPECIAL, INDIRECT OR CONSEQUENTIAL DAMAGES, WHETHER RESULTING FROM THE USE, MISUSE, OR INABILITY TO USE THE PRODUCT OR FROM DEFECTS IN THE PRODUCT. SOME STATES DO NOT ALLOW THE EXCLUSION OF INCIDENTAL OR CONSEQUENTIAL DAMAGES, SO THE ABOVE LIMITATIONS MAY NOT APPLY TO YOU.

Warranty Service: Warranty repair service shall be provided directly by uAvionix. Proof of purchase for the product from uAvionix or authorized reseller is required to obtain and better expedite warranty service.

Please email or call uAvionix support with a description of the problem you are experiencing. Also, please provide the model, serial number, shipping address and a daytime contact number.

You will be promptly contacted with further troubleshooting steps or return instructions. It is recommended to use a shipping method with tracking and insurance.

4 Table of Contents

1	Revision History	3
2	Warnings / Disclaimers.....	5
3	Limited Warranty	6
4	Table of Contents	7
5	Introduction	11
	5.1 Purpose	11
	5.2 Definition of Acronyms & Terms.....	11
6	AV-30-C System Information.....	12
	6.1 System Description.....	12
	6.2 System Functions	14
7	Certification	17
	7.1 Mechanical Instrument Replacement.....	18
	7.2 Non-Required Instrument Addition.....	18
	7.3 Vacuum System Removal.....	18
	7.4 Applicable Performance Standards.....	19
8	Installation Limitations	20
	8.1 Installation Approval Limitations.....	20
9	Installation Locations & Operating Modes	22
	9.1 Installation Locations	22
	9.2 Operating Mode Configuration	23
10	Functionality and Required Interfaces	24
	10.1 Aircraft Systems Connections	24
	10.2 Feature Matrix.....	25
	10.2.1 Power Input (Required)	26
	10.2.2 Pitot and Static Interfaces (Required)	26
	10.2.3 Outside Air Temp Input (Optional)	26
	10.2.4 Audio Output (Optional).....	27
	10.2.5 GPS Interface (Optional)	28
	10.2.6 Internal Magnetometer (Optional).....	29
	10.2.7 AV-Mag External Magnetometer (Optional)	29
	10.2.8 Transponder Control (Optional)	29
	10.2.9 AV-Link Interface (Optional)	29
	10.2.10 Autopilot Interfaces (Optional)	30
	10.3 Internal Battery Operation.....	30

11	Equipment Installation	32
11.1	Overview.....	32
11.2	Supplied Components.....	32
11.3	Non-Supplied Components	33
11.4	Installation Records	33
11.5	Mechanical Drawing.....	34
11.6	Mounting Screw Length Restriction.....	35
11.7	Wiring Diagrams	39
11.8	Bonding Requirements	42
11.9	Unit Pinout	44
12	Optional Equipment Installation	45
12.1	AV-Link	45
12.1.1	System Function.....	45
12.1.2	FCC ID	45
12.1.3	AV-Link Specifications.....	46
12.1.4	AV-Link Software.....	47
12.1.5	AV-Link Installation Materials and Tools.....	47
12.1.6	Additional Required Equipment	47
12.1.7	Mounting	47
12.1.8	Removing AV-30-C From Instrument Panel (Optional)	47
12.1.9	AV-30-C Backshell Connector Removal	47
12.1.10	AV-Link Attachment.....	48
12.1.11	AV-30-C Reinstallation in Instrument Panel.....	49
12.1.12	Continued Airworthiness.....	50
12.1.13	System Limitations	50
12.1.14	Connecting to the AV-Link via Wi-Fi	50
12.1.15	Wi-Fi Firmware Update Page	52
12.1.16	AV-Link Factory Reset.....	52
12.2	Transponder (tailBeaconX)	54
12.2.1	Transponder Control.....	55
12.2.2	Transponder Testing with AV-30-C	55
12.3	AV-Mag External Magnetometer	55
12.3.1	Magnetometer Overview	55
12.3.2	System Function.....	55
12.3.3	AV-Mag Specifications	56
12.3.4	AV-Mag Software	57

12.3.5	AV-Mag Installation Overview.....	57
12.3.6	AV-Mag Installation Materials and Tools	58
12.3.7	Additional Required Equipment	58
12.3.8	Enable the AV-Mag	58
12.3.9	AV-Mag Installation Location and Interference Monitor	60
12.3.10	AV-Mag Installation Orientation and Attitude	62
12.3.11	Calibration	66
12.3.12	AV-Mag Yaw Angle	67
12.4	AV-APA (Reserved)	67
12.5	Digital Autopilots (Reserved).....	67
12.6	AV-HSI (Reserved)	67
13	Setup & Configuration	68
13.1	Startup and Common Controls.....	68
13.2	Available Menus.....	69
14	Installation Menu	70
14.1	Mandatory Settings	74
14.1.1	Unit Function	74
14.1.2	Function Lock.....	75
14.1.3	Trim.....	75
14.1.4	Speed Assist	75
14.1.5	Angle of Attack	76
14.1.6	V-Speeds	76
14.1.7	Display Units	76
14.1.8	Serial Inputs	76
14.1.9	AID Mode	79
14.1.10	Demo Mode.....	80
14.2	System Checkout.....	80
14.2.1	Alignment	80
14.2.2	Gyro Calibration	81
14.2.3	On-Ground External Magnetometer Calibration.....	83
14.2.4	OAT Interface.....	87
14.2.5	GPS Navigator Interface.....	88
14.2.6	Vibration Check.....	88
14.2.7	Air Data - Pitot Zero.....	90
14.2.8	Air Data - Altitude Trim	91
14.2.9	Air Data – IAS Trim	92

	14.2.10 AV-APA Checkout (Reserved).....	93
	14.2.11 EMC Checkout	93
15	Troubleshooting	96
16	Instructions for Continued Maintenance & Operation	98
17	Aircraft Flight Manual Supplements.....	99
18	Serial Interface Specification.....	100
19	Field Update Capability	101
20	Appendix A: Example Wiring Schematics.....	102

5 Introduction

5.1 Purpose

This installation manual applies to the following articles:

- AV-30-C (Certified)
- AV-Mag (Certified)
- AV-Link (Certified)

5.2 Definition of Acronyms & Terms

Acronym	Definition
AI	Attitude Indicator
AoA	Angle of Attack
BARO	Barometer; barometric
DALT	Density Altitude
DG	Directional Gyroscope
GPS	Global Positioning System
HIRF	High-Intensity Radiated Field
IAS	Indicated Airspeed
MFD	Multi-Function Display
OAT	Outside Air Temperature
TAS	True Airspeed
TSO	Technical Standard Order
V _{MC}	Minimum controllable airspeed
V _{YSE}	Best rate-of-climb speed with one engine inoperative
V _{SO}	Minimum stall speed with gear and full flaps. The bottom end of the ASI white arc.
V _{S1}	Minimum steady flight velocity while still controllable. The bottom end of the ASI green arc.
V _{FE}	Maximum flap extended velocity. The top end of the ASI white arc.
V _{NO}	Maximum normal operating velocity. The top end of the ASI green arc.
V _{NE}	Maximum velocity in smooth air (never exceed). The red line at the top end of the ASI yellow arc.
V _{MC}	Minimum control airspeed with the critical engine inoperative
V _{YSE}	Speed for best rate of climb OEI (single engine)

6 AV-30-C System Information

This document provides instructions on the installation requirements for the uAvionix AV-30-C multi-mode instrument and related accessories.

6.1 System Description

The uAvionix AV-30-C is a fully digital multi-mode instrument that mounts in the legacy 3-1/8" round instrument panel. It can be field configured as an Attitude Indicator (AI), Directional Gyro (DG), or Multi-Function Display (MFD). It is fully self-contained with dual-precision inertial and pressure sensors and allows for a wide variety of pilot customization. Transponder control is available in both AI and DG modes.



Figure 1 – AV-30-C Multi Mode AI/DG/Transponder – Basic Display

When configured as an AI, primary attitude and slip are always displayed. The unused portions of the display area can be customized by the pilot to show a variety of textual and graphical data overlay fields. Three pages may be customized by the pilot while a fourth page presents a fully decluttered view of attitude and slip, while optionally presenting transponder controls.

When configured as a Directional Gyro (DG), direction of flight information is presented. The flight direction can be configured to be presented as a non-slaved heading or inertially stabilized GPS track when connected to an external GPS navigator. Multiple display presentations, including compass rose, GPS HSI, and GPS ARC views can be selected by the pilot. The unused portions of the display area can similarly be configured for a variety of textual data-overlays.

When configured as a Multi-Function Display (MFD) with the optional AV-Link accessory, traffic information is displayed from compatible ADS-B receivers. Note that this information is for advisory purposes only.

In all operating modes, the pilot may select from multiple visual styles which are intended to improve visual compatibility with legacy aircraft instrumentation and preserve the look-and-feel of older aircraft applications.

A wide variety of supplemental functions, including audio alerting, derived angle of attack presentation, g-load display, and more are provided. An internal, rechargeable battery allows for operation for a nominal 1 hour with the standard Lithium-Ion battery pack or 2.5 hours with the extended NiMH battery pack in the event of aircraft power loss in flight and 30 minutes minimum under all temperature conditions.

See *AV-30-C Pilots Guide UAV-1003946-001* for additional details.

6.2 System Functions

Primary Functions:

- Primary Attitude (AI Mode)
- Primary Slip (AI Mode)
- Primary Direction of Flight Indication (DG Mode)

Supplemental Functions:

- Indicated Airspeed
- Altitude
- V-Speeds
- Angle of Attack
- Vertical Trend
- Vertical Speed
- Set Altitude
- Heading
- Bus Voltage
- G Load
- Outside Air Temp
- True Airspeed
- Density Altitude
- GPS Navigator / Waypoint Data
- GPS Navigator Nav Data
- GPS Navigator Route Line
- Heading Bug
- MFD traffic page with AV-Link
- Transponder Control (AI / DG Mode)

Audio and Visual Alerting Functions:

- AoA Alerting
- G Limit Alerting
- Excessive Roll Alerting
- Set Altitude Alerting
- Carbon Monoxide Alert with AV-Link and Sentry

Misc. Functions:

- Internal Battery Operation
- Auto / Manual Brightness

Table 1 - System Specifications

Electrical Attributes	
Input Voltage Nominal	+10 to +32 VDC
Input Voltage Max	+60 VDC
Input Power Nominal	6 Watts (0.5 Amps @ 12VDC)
Input Power Max	12 Watts (1.0 Amps @ 12VDC)
Required Circuit Breaker	2 Amp
Operation on Battery	1 Hrs. Typ. @ 20°C / 30 Min Minimum @ -20C
Physical Attributes	
Mounting Configuration	3-1/8" Round Instrument Hole
Electrical Connector	15 Pin Male D-Sub
Pneumatic Connectors	1/4" OD Quick Connect
Mounting	(4X) #6-32 Machine Screws
Case Material	Billet Aluminum
With Standard Lithium-Ion Battery Pack - UAV-1003429-001 or UAV-1003429-002	
Dimensions w/o Connector	3.38" x 3.38" x 2.49"
Weight	0.56 Lbs.
With Extended NiMH Battery Pack – UAV-1003429-003	
Dimensions w/o Connector	3.38" x 3.38" x 3.49"
Weight	0.90 Lbs.
Environmental	
Ground Survival Low	-55°C
Operating Low	-20°C
Ground Survival High	+85°C
Operating High	+55°C
Altitude	25,000 Feet (maximum)
Optical Characteristics	
Diagonal Size	3" Circular
Contrast Ratio (Typical)	500
Brightness (Typical)	1000 cd/m ²

Viewing Angle Left/Right	60°
Viewing Angle Up	45°
Viewing Angle Down	10°
Backlight Lifetime (Typical)	50,000 Hours

7 Certification

This installation manual provides mechanical and electrical information necessary to install the AV-30-C. The content of this manual assumes use by competent and qualified personnel using standard maintenance procedures in accordance with Title 14 of the Code of Federal Regulation (CFR) and other related accepted procedures.

The certification basis for the AV-30-C is 14 CFR Part 23, Amendment 23-61. Installation is approved as a Level A system and is robust to High Intensity Radiated Field (HIRF) and lightning levels applicable for both metallic and non-metallic aircraft.

 The AV-30-C is approved for primary Attitude, Slip and Direction of Flight.

All other functionality is supplemental in nature and may not satisfy regulatory requirements for required instrumentation.

 The installer must ensure that all installation limitations as defined in this document are observed.

The internal battery capacity has been tested and verified to provide 30 minutes of operational capacity (with reserve), and meets the requirements defined in CFR 23.1311(a)(5) and 23.1353(h), allowing independent operation from the primary electrical power system.

See §10.3 Internal Battery Operation for additional battery operational characteristics.

 For aircraft capable of acrobatic flight, the AoA indication may become unreliable for operation in inverted flight and maneuvers exceeding ± 8 G.

7.1 Mechanical Instrument Replacement

Approval is granted to replace legacy mechanical instrumentation as follows:

- Installation of the AV-30-C (Dedicated AI mode) as the primary source for attitude and slip. Installation replaces the existing stand-alone vacuum or electrically powered attitude indicator.
- Installation of the AV-30-C (Dedicated DG mode) as the primary source for direction-of-flight. Installation replaces the existing stand-alone vacuum or electrically powered non-slaved directional gyro indicator.

Note that when installed as a DG, a reversionary AI is available for display. This functionality is supplemental only and does not satisfy requirements for a backup or standby attitude, turn and slip, or turn coordinator.

7.2 Non-Required Instrument Addition

Approval is granted to install the AV-30-C as a non-required instrument, augmenting existing required instrumentation. In this configuration, the AV-30-C must not replace an existing required instrument.

7.3 Vacuum System Removal

The aircraft's vacuum system typically may be removed under a field approval process (FAA Form 337) if no other systems or equipment requires it. The AV-30-C installation approval does not address this alteration.

7.4 Applicable Performance Standards

The AV-30-C and associated accessories were designed to, and satisfy, the applicable performance requirements defined in the following design standards:

Table 2 - Applicable Performance Standards

MOPS	Title	Category
SAE AS8019	Airspeed Instruments	Type B
SAE AS392C	Altimeter, Pressure Actuated, Sensitive Type	Type I
SAE AS8005A	Standard Temperature Instruments	Class IIIc
SAE AS8034	Airborne Multipurpose Electronic Displays	N/A
RTCA DO-334	Attitude and Heading Reference Systems (AHRS)	A5 H9 T7
SAE AS8013A	Minimum Performance Standard for Direction instrument, Magnetic (Gyroscopically Stabilized)	N/A
ASTM F3011-13	Angle Of Attack System	N/A
RTCA DO-347	Cert and Test for Small and Med LiPo Batteries	Medium Size

8 Installation Limitations

The following section provides the FAA approved installation limitations.

8.1 Installation Approval Limitations

This article meets the minimum performance and quality control standards required by an Approved Model List - Supplemental Type Certificate (AML-STC) and when installed on aircraft approved on the AML can be approved for return to service after installation.

If installation for an aircraft that is not listed on the AML, separate approval must be obtained. The following installation limitations apply:

- **Installation is restricted to CFR Part 23, Class I and II (gross take-off weight of no more than 6000 lbs) aircraft.**
- **Installation is restricted to aircraft with a 25,000-foot maximum (or less) ceiling limitation.**
- **Installation is restricted to aircraft with equal to or less than 300 knot Vne airspeed.**
- **Installation may not be performed as part of an integrated autopilot system including heading bug interface, attitude source or flight director display.**
- **Installation may not be performed as a replacement of a Horizontal Situational Awareness Indicator (HSI).**
- **In installations where the primary attitude indicator is being replaced, the existing airspeed and altimeter must remain in their current locations.**
- **An electrical load analysis must be performed in association with the installation.**
- **Connection to the Audio interface is not allowed for IFR approved non-metallic aircraft due to indirect lightning protection limitations.**
- **A magnetic direction indicator must be installed in the aircraft.**
- **An EMI/EMC checkout must be performed in association with the installation (This limitation is added to ensure verification of non-interference with Wi-Fi functionality).**

- **A magnetic interference checkout must be performed in association with AV-Mag installation.**

9 Installation Locations & Operating Modes

9.1 Installation Locations

The following figure shows a typical “six-pack” and one possible arrangement of instrument locations:

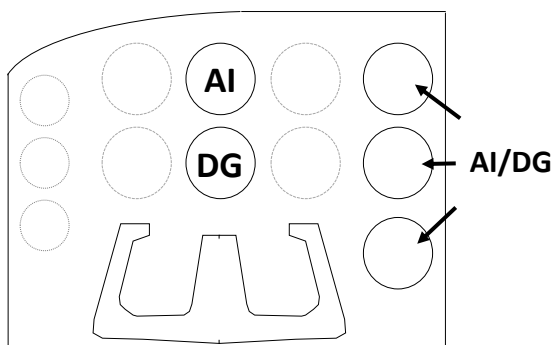





Figure 2 – Mechanical Gauge Replacement

Note that the physical arrangement in many aircraft varies from the configuration shown above. The AI/DG locations are examples of installation locations as a non-required instrument.

-  The existing mechanically based altimeter and airspeed indicator must remain in their current locations for this installation configuration.
-  Installation as a pilot configurable AI/DG may not replace a primary instrument.

The replaced instruments may NOT be part of an autopilot or primary navigational display, such as an integrated autopilot system, autopilot heading bug source, attitude source, CDI, HSI or flight director display.

-  Reference CFR 23.1321 Arrangement and Visibility for additional FAA guidance on instrument installation location.

9.2 Operating Mode Configuration

The AV-30-C operating mode is configured during installation and can be set as follows:

- Unit locked as a dedicated Attitude Indicator (AI Mode)
- Unit locked as a dedicated Direction Indicator (DG Mode); can be toggled between DG and MFD mode.
- Unit unlocked; can be toggled between AI, DG, and MFD modes by the pilot.

Installations where dedicated functionality is required must have the associated setting configured in the setup procedures. This setting is mandatory and non-pilot accessible.

If the functionality is not locked, pressing and holding the rotary knob will toggle between AI, DG, and MFD modes. This mode is only applicable for installation as a non-required instrument.

 An AV-30-C that replaces the Attitude Indicator must have the operating mode locked as an AI.

 An AV-30-C that replaces that Directional Gyro must have the operating mode locked as a DG.

 An AV-30-C installed as a non-required indicator may be configured in any operating mode based on pilot preference.

Replaced instruments may NOT be part of an autopilot system such as the rate-of-turn source for an autopilot or display of flight director information from an autopilot.

10 Functionality and Required Interfaces

10.1 Aircraft Systems Connections

All aircraft systems connections are provided on a single 15-Pin D-sub connector and two quick-connect pneumatic fittings. Various interfaces are optional, and interface to some systems may require additional installation approval. Do not plug the pitot and static lines.

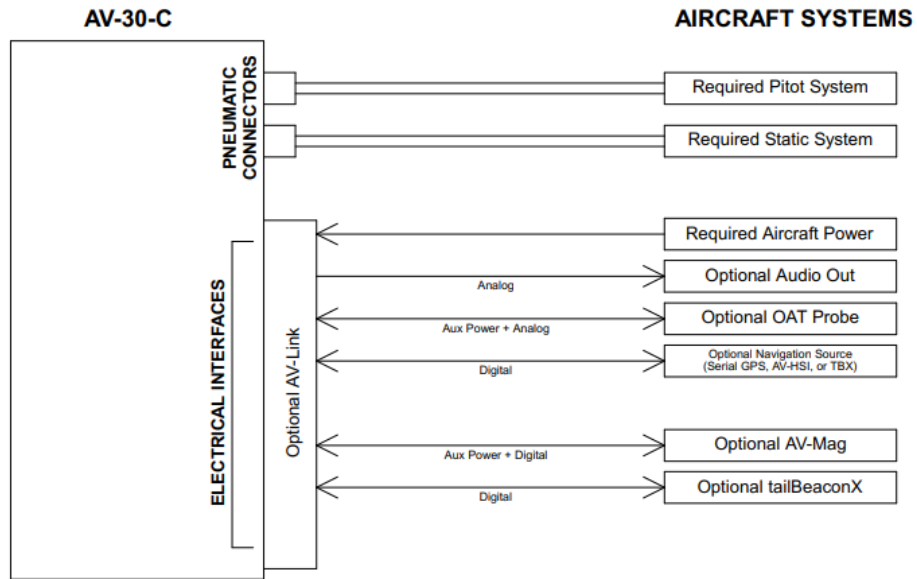

Figure 3 – AV-30-C Aircraft Systems Interfaces – AI Mode

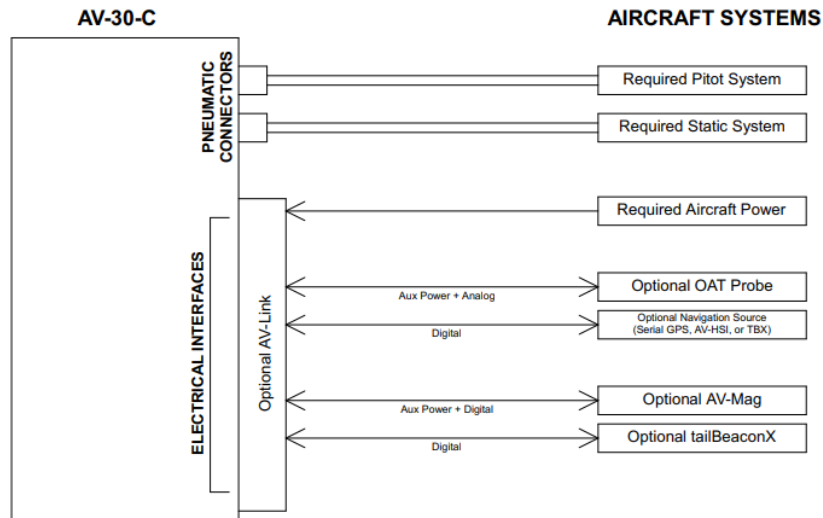

Figure 4 - AV-30-C Aircraft Systems Interfaces – DG Mode

10.2 Feature Matrix

The following matrix shows primary and supplemental data and any required external interface.

Table 3 - Feature Matrix

Feature	AI Mode	DG Mode	Required Interface
Primary Attitude and Slip			
Primary Attitude	✓	✗	Pitot & Static
Primary Slip	✓	✗	Pitot & Static
Reversionary Attitude / Slip	✓	✓	Pitot & Static
Primary Direction of Flight Indication			
Direction Tape (DG / [GPS])	✓	✗	Pitot & static / [GPS Navigator]
Direction Rose (DG / [GPS])	✗	✓	Pitot & static / [GPS Navigator]
Direction Arc (DG / [GPS])	✗	✓	Pitot & static / [GPS Navigator]
Direction HSI (DG / [GPS])	✗	✓	Pitot & static / [GPS Navigator]
Supplemental Data Overlays – Pilot Configurable (Textual or Graphical)			
Indicated Airspeed (Textual)	✓	✗	Pitot & Static
V-Speeds (Graphical)	✓	✗	Pitot & Static
Baro Altitude (Textual)	✓	✓	Pitot & Static
Angle Of Attack (Graphical)	✓	✗	Pitot & Static
Vertical Trend (Graphical)	✓	✗	Pitot & Static
Vertical Speed (Textual)	✓	✓	Pitot & Static
Set Altitude (Textual)	✓	✓	None
Heading (Textual)	✓	✓	Pitot & Static
Bus Voltage (Textual)	✓	✓	None
G Load (Textual)	✓	✓	None
Outside Air Temp (Textual)	✓	✓	OAT Probe
True Airspeed (Textual)	✓	✓	Pitot & Static, OAT Probe
Density Altitude (Textual)	✓	✓	Pitot & Static, OAT Probe
Carbon Monoxide (Textual)	✓	✓	AV-Link + Sentry ADS-B Receiver
GPS Navigation / Waypoint Data			
Textual Nav Data	✓	✓	GPS Navigator
Graphical Nav Data	✗	✓	GPS Navigator
Heading Bug			
Hdg Bug – Ref Only, no AP	✓	✓	None
Audio and Visual Alerting			
AoA Alerting	✓	✗	Pitot & Static
G Limit Alerting	✓	✗	None
Excessive Roll Alerting	✓	✗	None
Carbon Monoxide	✓	✓	AV-Link + Sentry ADS-B Receiver
Misc.			
Internal Battery Operation	✓	✓	Pitot & Static
Auto / Manual Brightness	✓	✓	None
Transponder Control	✓	✓	Transponder Serial, Pitot & Static
Traffic display	✓	✓	AV-Link + ADS-B Receiver, Pitot & Static
External Magnetometer aid	✓	✓	AV-MAG, Pitot & Static

10.2.1 Power Input (Required)

Power input is required in all configurations and each unit has a dedicated circuit breaker. The power input is internally connected, and diode protected with the unit's internal battery via a processor-controlled switch. This architecture allows the unit to continue operation if external power fluctuates or is completely lost. Input range is compatible with both 12V and 24V aircraft.

Each AV-30-C must have a dedicated, properly labeled, pilot resettable circuit breaker as part of the installation. Power for the unit should be supplied from the main battery master relay. It is recommended to shield the power wire.

10.2.2 Pitot and Static Interfaces (Required)

Pitot and static connections are required for all modes.

Airspeed, altitude, attitude, derived angle of attack (AoA), True Airspeed (TAS), Density Altitude (DALT), DG heading, and traffic altitude all require pitot and static connections as they are based on either altitude or airspeed measured from those connections.

When installed as a DG, backup battery in flight, and DG heading aid require the pitot and static connections to be connected. TAS, DALT, altitude and vertical speed are the only air-data related parameters that can be displayed when in DG mode.

Pitot and static data aids the attitude algorithm, using a feature called speed assist.

10.2.3 Outside Air Temp Input (Optional)

The optional outside air temperature interface requires a dedicated external analog probe. This port connection is compatible with the Davtron P/N C307PS (not supplied).

This is a differential two-wire current source based on the Analog Devices AD590KH component and supplies a current that corresponds to the ambient temperature.



If two displays are connected to the same probe, the current will be split between the two and incorrect readings will be shown by both.

The sensor reading must be trimmed during the installation process to compensate for probe-to-probe variations.

The OAT probe is automatically detected by the system, and when detected, allows temperature related parameters to be selected for display by the pilot.

If the OAT probe is not detected, display of these parameters will automatically be inhibited.

10.2.4 Audio Output (Optional)

The optional audio panel connection is a low-voltage analog output that is designed to connect directly to an audio panel (typically a non-switched or unswitched audio input). High power outputs capable of directly driving a cockpit speaker are not provided.

Other unswitched unmuted inputs can be used but they may need to be mixed with an existing audio source. Audio shields must be grounded only at audio panel to avoid ground loops. Contact audio manufacturer for further instructions.

When installed as a DG, no audio alerting is supported, and this output should remain disconnected.



In non-metallic, IFR capable aircraft, this connection **MUST** remain disconnected due to lightning strike limitations.

10.2.5 GPS Interface (Optional)

The GPS interface is an optional RS-232 serial input that is compatible with the industry standard “Aviation” output provided by most panel mounted GPS units, and NMEA serial interfaces provided by most hand-held GPS units.

This is a text/binary protocol output by the GPS navigator that contains situational awareness information such as ground speed, track, distance to destination, cross track, etc., and is typically utilized by remote mapping/display products to provide additional pilot awareness.

This output does not provide IFR compliant lateral or vertical guidance, therefore all deviation related data presented is for VFR operations only.

The AV-30-C does not alter the data obtained from the GPS navigator and simply displays the received data in a textual or graphical format as configured by the pilot. The AV-30 will convert ground speed units to match IAS units for textual display.



Aviation and NMEA GPS may be connected in parallel between multiple AV-30 units and is supported in both AI and DG modes.

The supported protocols are listed in §18 - Serial Interface Specification.

Table 4 GPS Functions by receiver type

GPS Receiver	GPS Track	VFR Guidance	MFD Traffic Display
uAvionix BeaconX	✓	✗	✗
Aviation 4800	✓	✓	✗
Aviation 9600	✓	✓	✗
NMEA 4800	✓	✓	✗
uAvionix Sentry + AV-Link	✗	✗	✓
GDL90 ADS-B Receiver + AV-Link	✗	✗	✓

Table 4 depicts the GPS functions performed by each receiver type. BeaconX transponders provide GPS track but do not have a waypoint database to provide navigation guidance.

10.2.6 Internal Magnetometer (Optional)

The internal magnetometer, when available, is detected in software version 2.1.2 or later. It is currently disabled by configuration.

10.2.7 AV-Mag External Magnetometer (Optional)

The AV-Mag external magnetometer is supported in software version 2.3.9 or later. It is enabled with manual configuration in the installation menu. The installation of the AV-Mag magnetometer is sensitive to orientation and tilt so the installation instructions must be followed carefully. The magnetometer also requires calibration before use. The AV-Mag receives power from the AV-30-C and will run off the AV-30-C internal battery in case of power loss. The AV-Mag transmits data to the AV-30-C via an RS-232 serial interface.



The RS-232 serial interface may be connected in parallel to multiple AV-30-C units.

10.2.8 Transponder Control (Optional)

The AV-30-C has the option of being the control interface for select uAvionix transponders (including the BeaconX family). This provides pressure altitude, mode, squawk code, and IDENT information to the transponder, and displays status and annunciations from the transponder.



The transponder is not powered by the AV-30-C internal battery. Transponder operations will be unavailable during a power loss.

10.2.9 AV-Link Interface (Optional)

The AV-30-C has the option of being a traffic display using AV-Link as an integrated Wi-Fi bridge that allows for communication between AV-30-C and Wi-Fi capable ADS-B receivers. The AV-30-C will display a

separate MFD page with traffic when appropriate configured and connected to a supported receiver.



The AV-Link accessory is not powered by the AV-30-C internal battery. Wi-Fi traffic data provided to the MFD mode will be unavailable during a power loss.

10.2.10 Autopilot Interfaces (Optional)

Integrations with autopilots are not approved in certified aircraft. They are currently disabled by configuration.

10.3 Internal Battery Operation

The internal battery consists of a rechargeable battery system with automatic recharge, self-test, and power switching capability.

AV-30-C part numbers UAV-1003429-001 and UAV-1003429-002 include a standard Li-Ion battery pack that will provide approximately 1 hour of operation at standard temperatures and 30 minutes (minimum) of operational capacity over the operational temperature range.

AV-30-C part number UAV-1003429-003 includes an extended NiMH battery pack that will provide approximately 2.5 hours of operation at standard temperatures and 30 minutes (minimum) of operational capacity over the operational temperature range.

When power is lost to the AV-30-C, the following will occur:

1. While AV-30-C is aligning, the unit will continue to battery mode if power is lost. Once aligned it will shut down.
2. If any button is pressed after power is lost, the AV-30-C will stay in battery mode.
3. If the AV-30-C senses airspeed or GPS groundspeed, it will stay in battery mode. For this reason, it is crucial that the AV-30-C is connected to pitot and static air system..

If the AV-30-C needs to be shut down after removing power, press and hold the left and right buttons until the unit shuts down.

See the *AV-30-C Pilots Guide UAV-1003946-001* §10 Internal Battery Operation for additional operational information.

11 Equipment Installation

11.1 Overview

Installation consists of the following steps:

- Remove / relocate any legacy instrumentation
- Add or locate an appropriate power source / breaker
- Wire power and system interfaces as needed
- Mount the unit to the instrument panel with supplied screws
- Apply power and perform setup
- Connect pitot and static to both AI and DG. Perform leak check after installation.

11.2 Supplied Components

Table 5 - Supplied Components

Component	Part Number	Description
AV-30-C Unit	UAV-1003429-001	AV-30-C Unit
	UAV-1003429-002	AV-30-C Unit with Internal Magnetometer
	UAV-1003429-003	AV-30-C Unit with Extended NiMH Battery Pack
AV-30-C Installation Kit	UAV-1004091-001	Installation Kit
AV-30-C Operating Software	UAV-1003494-007	AV-30-C Operating Software v2.5.0
AV-Mag (optional)	UAV-1006518-001	AV-Mag External Magnetometer
AV-Link (optional)	UAV-1004414-001	AV-Link

The AV-30-C Installation Kit includes the following:

- 6-32 mounting screws
- 15-pin harness housing and associated pins
- Braided ground cable
- Ring terminals

Note: the installation kit has been updated to use close barrel machined pins instead of the original open barrel stamped pins.

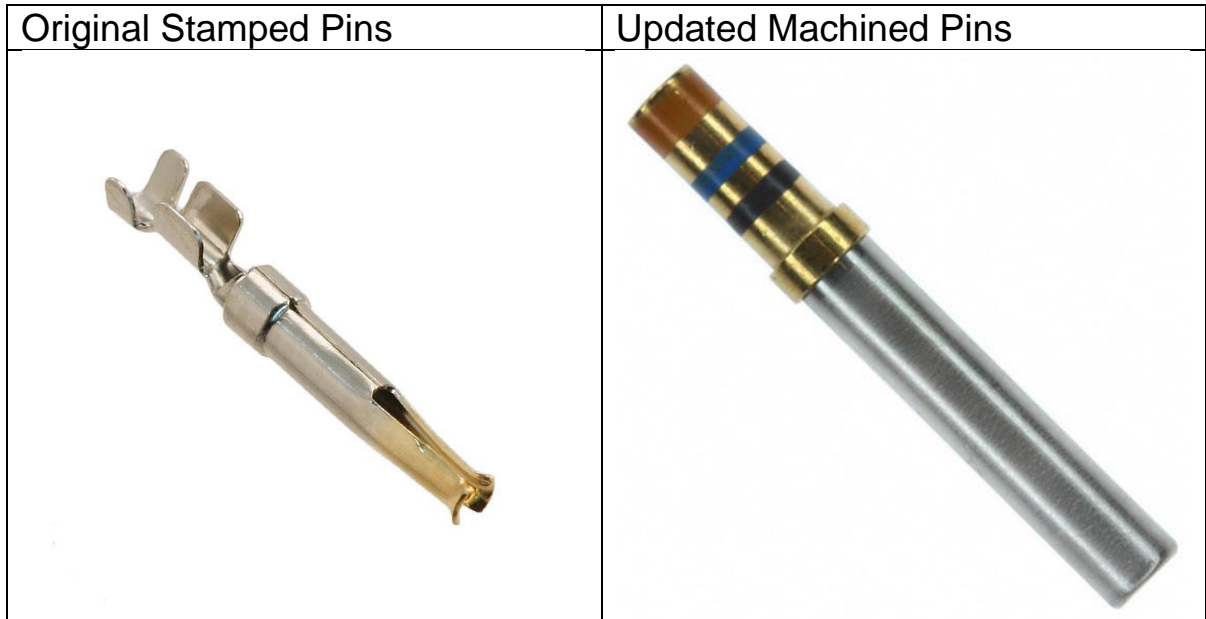

If your kit includes machined pins, a Daniels AFM8 crimp tool using a K13-1 positioner or equivalent M22520/2-01 tool should be used. If your installation kit includes the original stamped pins, a NorComp 180-701-170-000 hand crimper or equivalent should be used.

11.3 Non-Supplied Components

Table 6 - Non-Supplied Components

Component	Description
Pitot / Static Tubing	Length as required
Pitot Static T's	Quantity as required
Circuit Breakers (2A)	One required for each instrument
OAT Probe	Davtron P/N C307PS
Power and Interconnect Wire	22 or 24 AWG MIL-C-27500 shielded wire

11.4 Installation Records

The date of installation should be recorded in the aircraft's log-book.

Entry should include instrument(s) being replaced (AI or DG, or both), or, if the installation is being performed as a non-required instrument.

Entry should also include a description of any optional connections made.

Entry should include AV-Mag installation location, orientation, and attitude angles.

11.5 Mechanical Drawing

AV-30-C part numbers UAV-1003429-001 and UAV-1003429-002 include a standard depth Li-Ion battery pack, with mechanical dimensions shown in Figure 5 – Mechanical Drawing. The center drawing depicts an AV-30-C with an optional AV-Link attached.

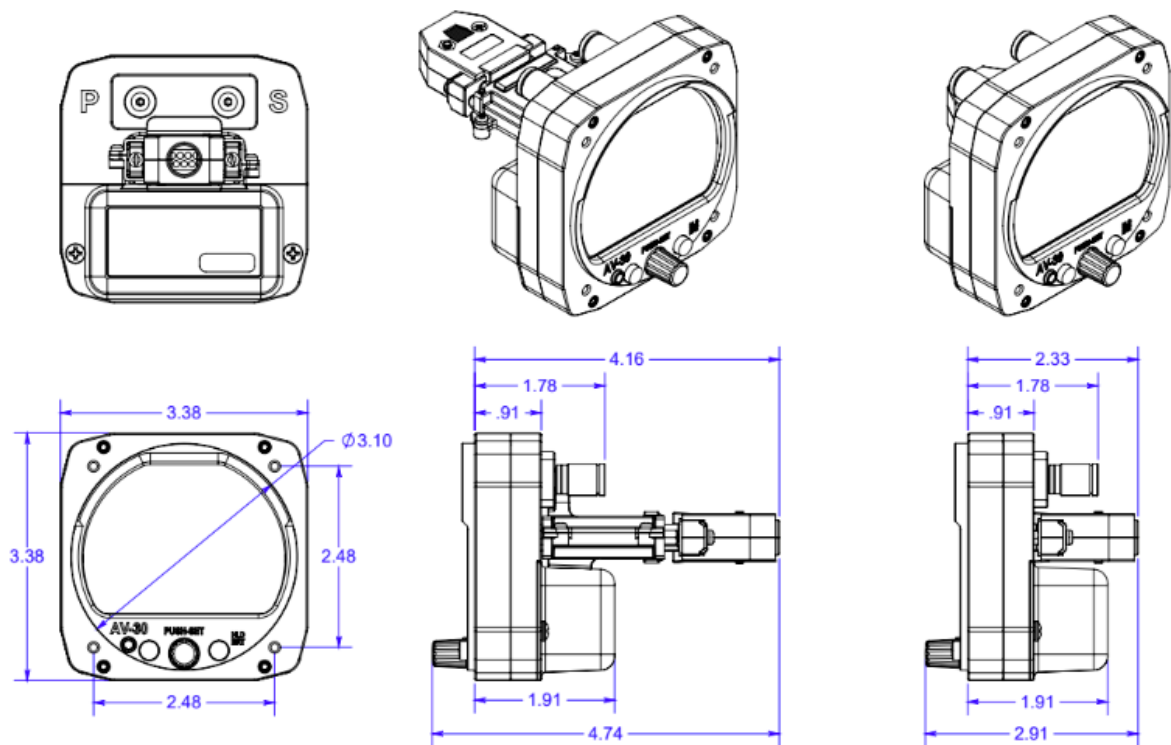

Figure 5 – Mechanical Drawing with Standard Li-Ion Battery

AV-30-C part number UAV-1003429-003 includes an extended NiMH battery pack, with mechanical dimensions shown in Figure 6 – Mechanical Drawing with Extended NiMH Battery. The center drawing depicts an AV-30-C with an optional AV-Link attached.

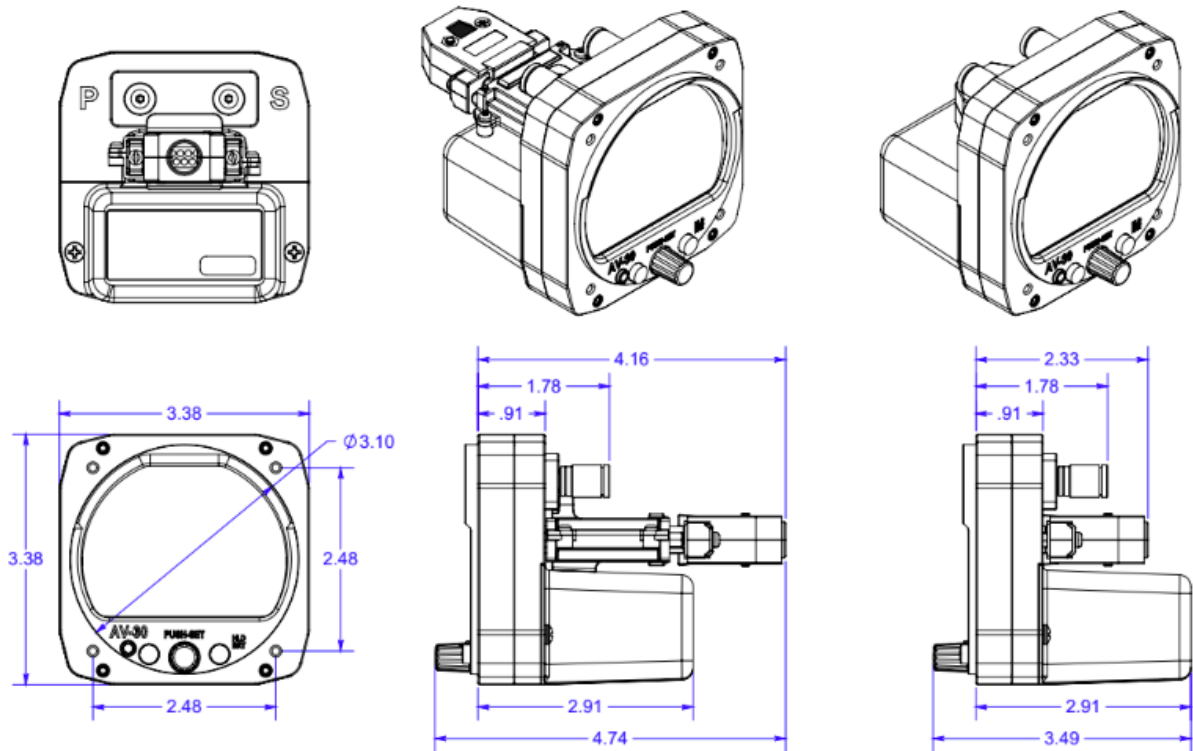

Figure 6 – Mechanical Drawing with Extended NiMH Battery

11.6 Mounting Screw Length Restriction

The AV-30 is fastened to the instrument panel with four Stainless Steel 6-32 screws. The unit mounts from the rear of the instrument panel, with the screws being inserted from the front of the panel.



The four 6-32 Mounting screws **must** observe depth limits given the internal component design. Using screws that are too long can break the housing and damage the components inside. For top screws, the maximum exposed thread length is 3.2 mm and the minimum is 2.7 mm. For bottom screws, the maximum is 4.2 mm and the minimum is 3.7 mm.



Torque screws to 6 (+/-1) inch-lbs. Do not over-torque or damage may occur.

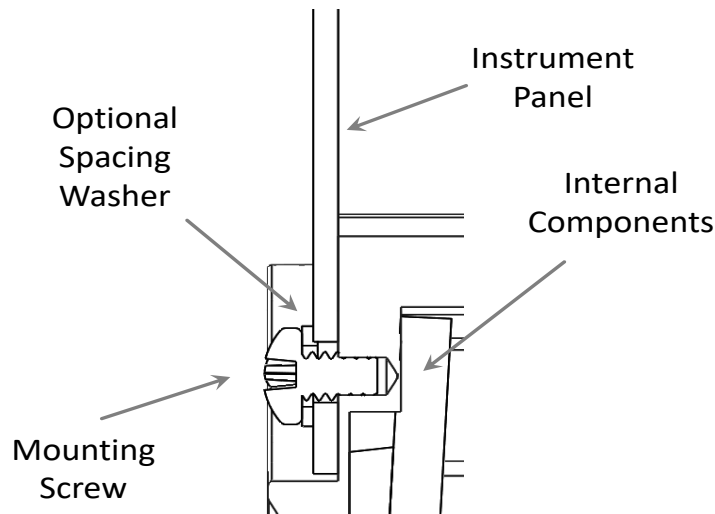

Figure 7 – Mounting Screw Depth Limits

Caution must be observed when mounting the AV-30. If too long a screw is used, damage to the unit can occur, and the unit may not be securely fastened to the panel. The installation kit contains multiple length screws to assist in compensating for different instrument panel thicknesses. Due to the short thread engagement, if you will be providing your own screws, be sure to choose stainless steel instead of brass as typically used for instrument mounting.

The objective when mounting the AV-30 is to achieve the greatest screw engagement without exceeding the limits of the housing, causing damage. Using screws that are too short could lead to stripped mounting holes. Always use caution when tightening the mounting screws, if the screw feels like it is bottoming out, STOP, and correct the screw thread engagement. Correct screw thread engagement may be determined and adjusted in the following ways.

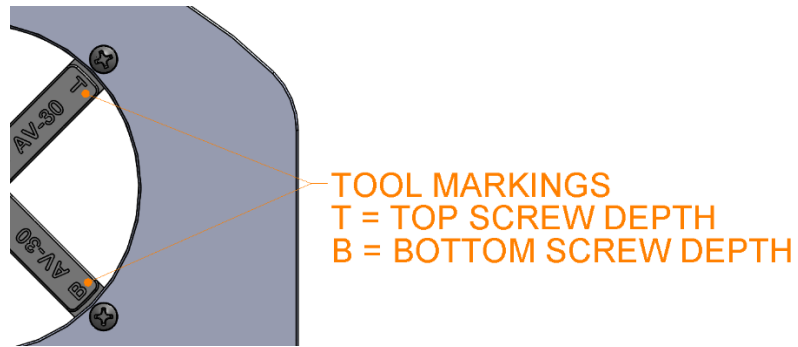

Figure 8 - Install tool used for Top and Bottom Screw Engagement Check

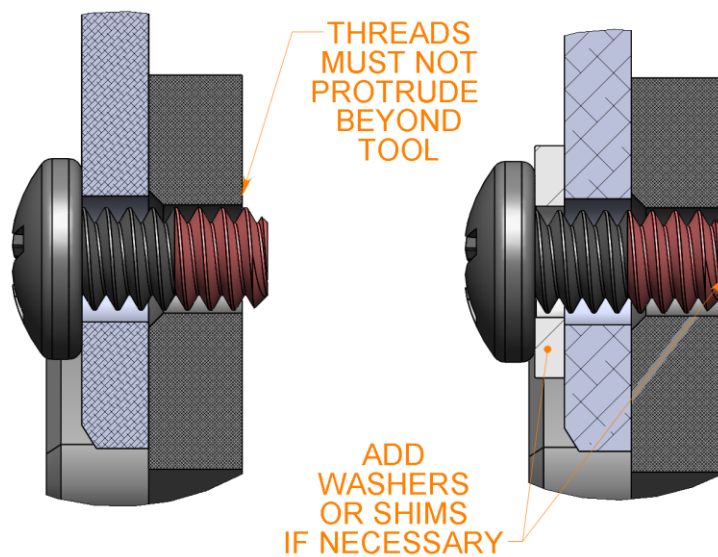

Figure 9 - Proper Screw Engagement Adjustment

- 1) Installation Tool: If the installation kit contains a screw depth gauge, perform the following steps to determine the correct screw lengths:
 - a. Hold the depth gauge behind the panel so the “T” hole on the depth gauge aligns with the top left screw hole in the panel. Place a mounting screw through the panel and feel the back surface of the tool where the screw should be. The screw can be flush with the tool surface or up to 0.5mm (0.020in) below the surface. If the screw protrudes past the depth gauge the screw is too long. Select a shorter screw or use standard hardware shims/washers installed under the head of the screw (not provided) to adjust the screw depth.
 - b. Perform step a. again, measuring the top right screw hole.

- c. Hold the depth gauge behind the bottom left screw hole, aligning the “B” hole on the depth gauge with the panel screw hole. Again, if the screw protrudes past the depth gauge the screw is too long. Select a shorter screw or use standard hardware shims/washers installed under the head of the screw (not provided) to adjust the screw depth.
- d. Perform step c. again, measuring the bottom right screw hole. Note that the lower two holes accommodate slightly longer screws than the upper two holes, but the same process should be used to achieve the greatest thread engagement.

2) Measurement: The permissible thread engagement in the top mounting holes is 3.2mm. The permissible thread engagement in the bottom mounting holes is 4.2mm. You can use digital calipers or other accurate means to measure the length of the screw (each screw may have manufacturing length variation), then measure your panel thickness. Subtract the panel thickness from your screw length. If this length is greater than 3.2 or 4.2 for each respective Top or Bottom location, you will need to add washers when installing the screws. Repeat this measurement of exposed threads with shims/washers on the screws until you are under and within 0.5mm (0.020in) of the listed depths.

- a. Screw thread length measured = 6.35mm (0.250in screw)
- b. Panel thickness measured = 2.29mm (0.090in panel)
- c. Thread engagement = $6.35 - 2.29 = 4.06\text{mm}$
 - i. This screw may be used in the Bottom Mounting holes since $4.06\text{mm} < 4.2\text{mm}$, but NOT in the top mounting holes as it is too long.
- d. Screw thread length measured = 4.76mm (0.1875in screw)
- e. Panel thickness measured = 2.29mm (0.090in panel)
- f. Thread engagement = $4.76 - 2.29 = 2.47\text{mm}$
 - i. This screw may NOT be used in the Top or Bottom Mounting holes since the length is too short. You will

need to use a longer screw or a longer screw with shims/washers.

- 3) Note: Installing an AV-30 into panel cutouts where one of the 4 mounting hole locations has been enlarged for prior Baro Setting knob, DG Adjustment knob, or Heading Bug knob clearance will increase the mounting difficulty. Use extreme caution when using reducing washers while adjusting screw engagement in these locations. The reducing washers will flex more than traditional washers causing the screws to have deeper engagement. You can still use the installation tool in this case by turning the tool over and aligning the Bottom depth gauge hole with the mounting hole while 'bridging' the tool across the opening to ensure it is flat on the back of the panel as shown below. Insert your reducing washer and screw and repeat the process from 1c above. Use caution when tightening the screw.

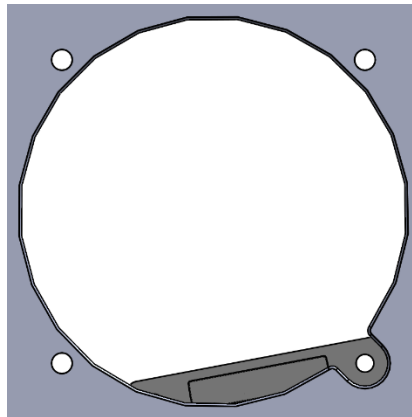

Figure 10 - Bridging using back side of tool when working with enlarged holes and reducing washers.

11.7 Wiring Diagrams

The AV-30-C performs different functions when installed as an AI or DG, and therefore wiring varies based on installation. Figure 11 and Figure 12 show connections for each configuration.

The primary difference is that the DG does not support audio alerting.

See ASTM F2639-18 Standard Practice for Design, Alteration, and Certification of Aircraft Electrical Wiring Systems §5.1 for acceptable wire types for both power and interconnect purposes.

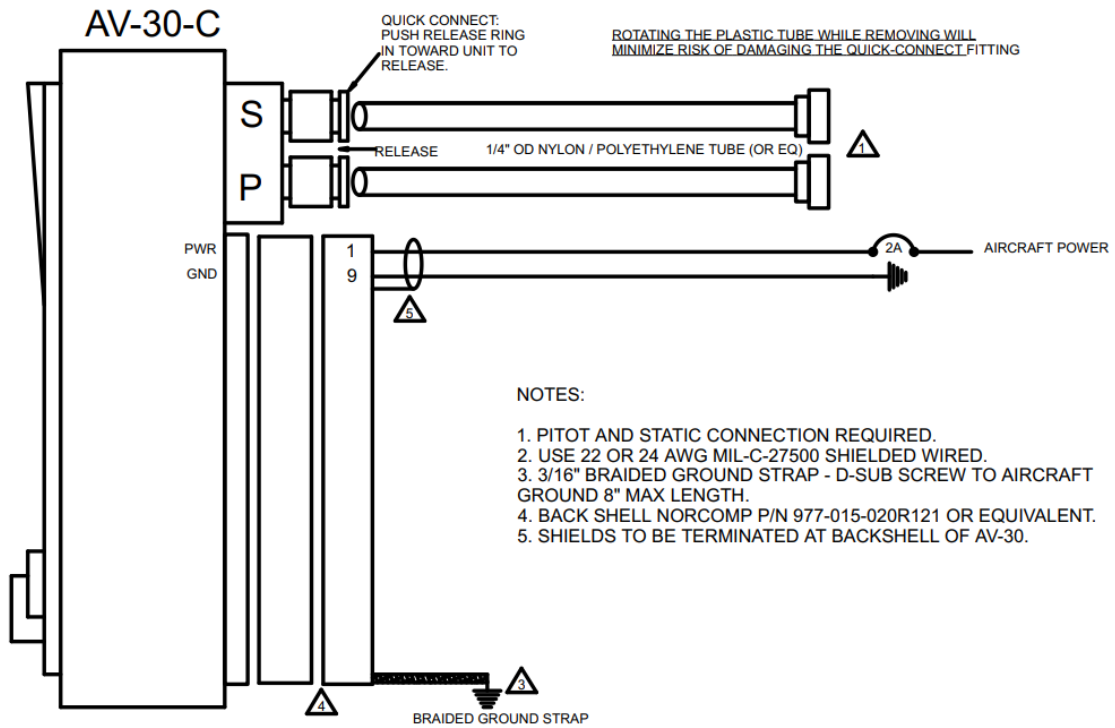
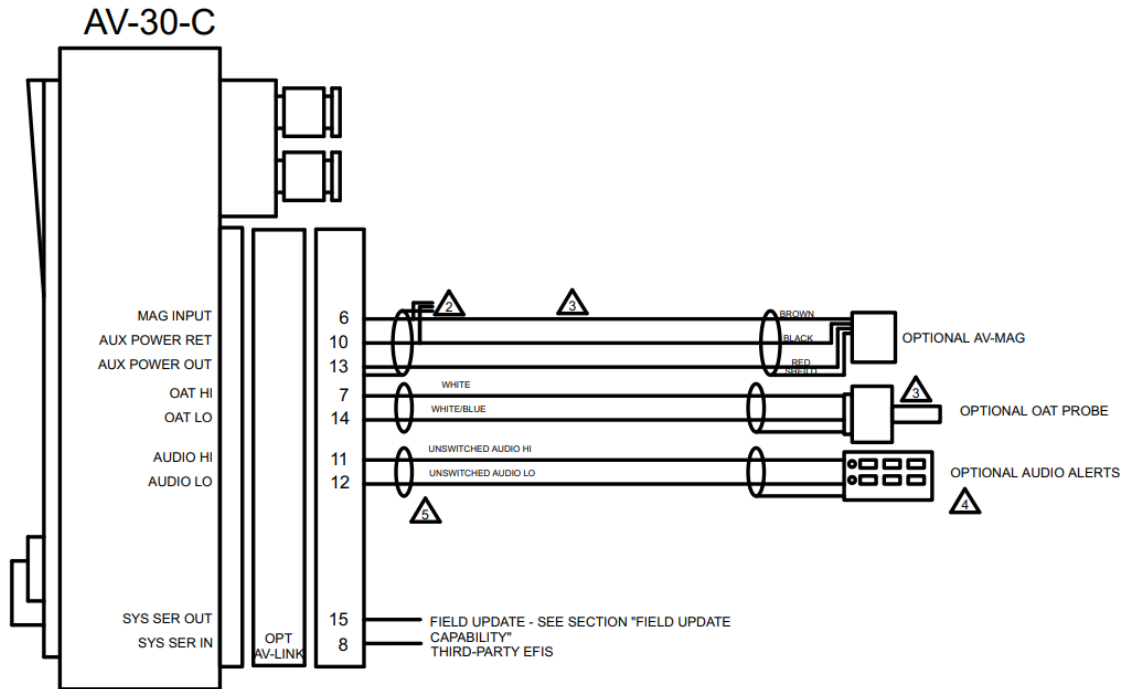

Figure 11 - Wiring Diagram - Required Connections



NOTES:

1. USE 22 OR 24 AWG MIL-C-27500 SHIELDED WIRED.
2. AV-MAG MAY BE PARALLELED TO ADDITIONAL AV-30. FOR PARALLEL OPERATION CONNECT PINS 6, 10, AND SHIELD TO ADDITIONAL AV-30. DO NOT CONNECT PIN 13 TO ADDITIONAL AV-30.
3. AV-MAG INCLUDES APPROXIMATELY 12" OF WIRE. EXTEND WITH M27500-24TG3T14, M27500-22TG3T14 OR EQUIVALENT.
3. FOR DALI, TAS, OAT, FUNCTIONALITY, PITOT, STATIC, AND OAT MUST ALL BE CONNECTED. OAT PROBE CAN NOT BE PARALLELED.
4. AUDIO ALERTS FOR FOR THE AI CONFIGURATION ONLY. DO NOT CONNECT IF INSTALLED AS DG.
5. DO NOT CONNECT WIRE SHIELD FOR AUDIO AT AV-30. CONNECT SHIELD ONLY AT AUDIO PANEL.
6. CONNECT AV-MAG SHIELD TO AV-30 BACK SHELL AND TO AV-MAG.

Figure 12 - Wiring Diagram – Optional Connections 1 of 2

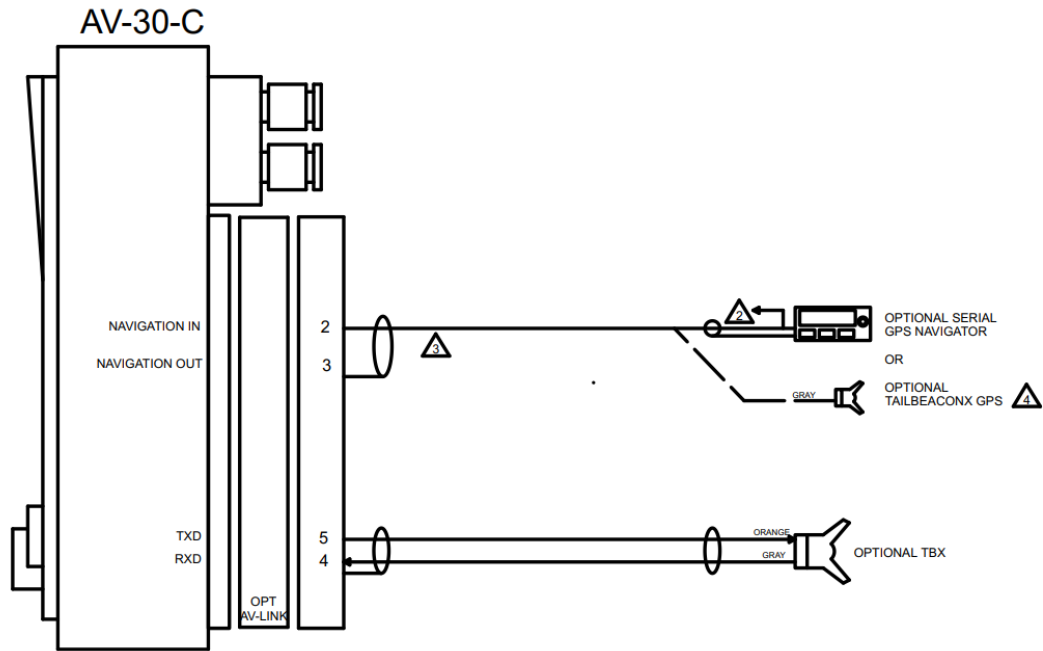

NOTES:

1. USE 22 OR 24 AWG MIL-C-27500 SHIELDED WIRED.
2. SERIAL GPS NAVIGATOR MAY BE PARALLELED TO ADDITIONAL AV-30.
3. ONLY ONE DEVICE MAY BE CONNECTED TO PINS 2 AND 3. CHOOSE BETWEEN SERIAL NAVIGATOR AND TAILBEACONX AS GPS.
4. AV-30 MAY SERVE AS A CONTROL HEAD FOR A TAILBEACONX OR MAY USE THE TAILBEACONX AS A GPS SOURCE. DO NOT CONNECT AS BOTH. SEE TRANSPONDER INSTALLATION INSTRUCTIONS FOR ADDITIONAL DETAILS.

Figure 13 - Wiring Diagram - Optional Connections 2 of 2

11.8 Bonding Requirements

The following figure shows the grounding requirements for the electrical connections. The two D-Sub screws are to be utilized for shield and ground strap connections.

The supplied ring terminal connectors are sized for these screws.

The ground braid strap is to be less than 8 inches in overall length and at least 3/16 width. Alpha Wire part number 1230 SV001 or equivalent.



Figure 14 – Ground Braid Strap – 8” or Less in Length

The exposed (non-shielded) portions of the interface cables AND the shield grounds are to remain less than 2.5 inches.

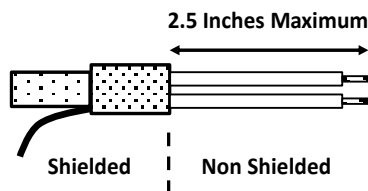

Figure 15 – Shielded Cable



The bond between the unit (measured at the D-sub screws) to the aircraft frame must be 2.5 milli-Ohms or less.

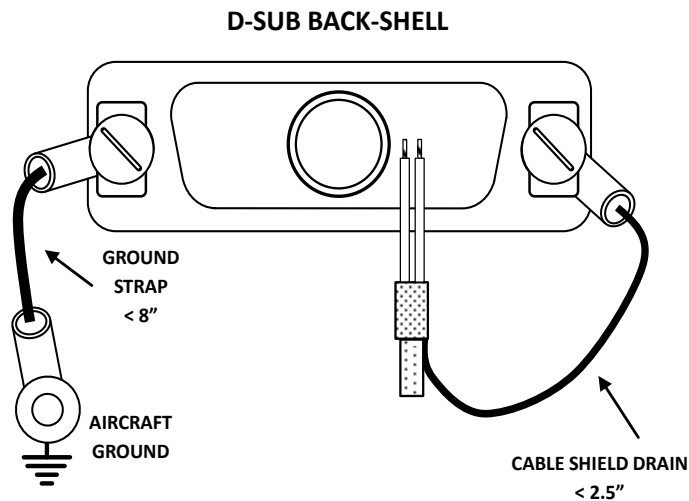

Figure 16 – Cable Shields and Ground Strap

11.9 Unit Pinout

Table 7 - Connector Pinout

Pin	Function	Type	Comment
1	Power	Power	+12 to +28 VDC
2	GPS Navigator	Input	GPS RS-232
3	Spare Serial	Output	Reserved - Do Not Connect
4	Serial 2	Input	Transponder RS-232
5	Serial 2	Output	Transponder RS-232
6	Serial 4	Input	AV-Mag Data
7	OAT Supply	Output	White Probe Wire
8	MFG Serial	Input	Reserved – Field Update
9	Ground	Power	Aircraft Ground
10	Aux Power Ret	Power	AV-Mag / Auxiliary Power return
11	Audio H	Output	Audio Alerts Hi
12	Audio L	Output	Audio Panel Lo
13	Aux Power Out	Power	AV-Mag / Auxiliary Power
14	OAT Return	Input	White / Blue Probe Wire
15	MFG Serial	Output	Reserved – Field Update

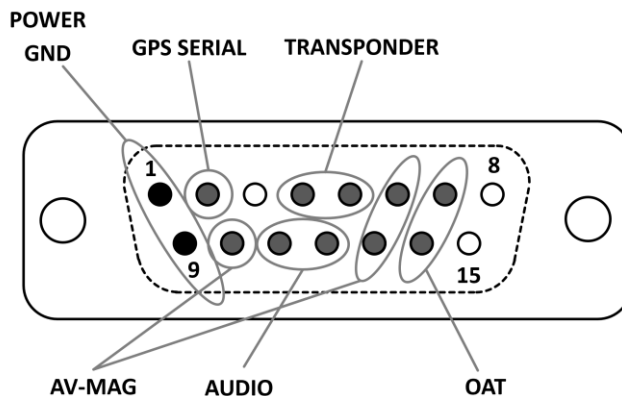

Figure 17 - Unit Connections – DB-15, Male (Rear Unit View)

12 Optional Equipment Installation

12.1 AV-Link

AV-Link (P/N UAV-1004414-001) is an integrated Wi-Fi bridge that allows for communication between AV-30 and Wi-Fi enabled devices. Software updates for AV-Link and AV-30 can be performed via a web page. Configuration settings and device status are accessible through the embedded web page. See §12.1.5 for steps on updating firmware using the AV-Link.

This installation manual provides mechanical and electrical information necessary to install AV-Link. It is not equivalent to an approved airframe-specific maintenance manual, installation design drawing, or installation data package. The content of this manual assumes use by competent and qualified personnel using standard maintenance procedures in accordance with Title 14 of the Code of Federal Regulation (CFR) and other related accepted procedures. This is an incomplete system intended to provide the functions identified in, and when installed according to this installation manual.

12.1.1 System Function

AV-Link and AV-30-C, when paired with an ADS-B receiver, can display traffic information. This information is supplemental and for advisory use only. It cannot replace required equipment.

12.1.2 FCC ID

Table 12-1 – FCC ID

Model	FCC ID
AV-Link Contains	2AC7Z-ESPWROOM02U

12.1.3 AV-Link Specifications

Table 12-2 – AV-Link Specifications

Characteristics	Specifications
Part Number	UAV-1004414-001
Width	52.06 mm
Height	25.91 mm
Depth	52.63 mm
Weight	1.1 oz (32.2 grams)
Operating temperature range	-45°C to +70°C
Maximum pressure altitude	35,000 ft
Input voltage range	9 to 30.3 VDC
14V current	0.02A idle 0.025A typical 0.05A maximum
28V current	0.01A idle 0.0125A typical 0.025A maximum

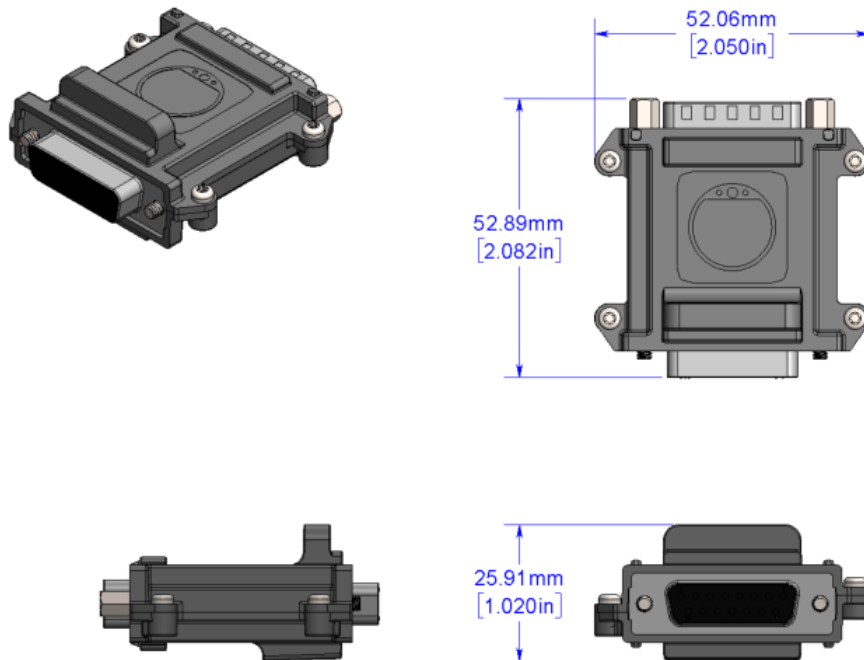

Figure 18 – AV-Link Mechanical Drawing

12.1.4 AV-Link Software

The software contained in the AV-Link device is identified by electronic marking. Software version information can be accessed via an embedded web page.

12.1.5 AV-Link Installation Materials and Tools

AV-Link installation requires access to these tools:

- Flat Screwdriver
- 3/16" Nut Driver

12.1.6 Additional Required Equipment

AV-Link is designed to interface with an existing AV-30 display. To take advantage of AV-Link the following equipment is required:

- AV-30-C 3-1/8" Display

12.1.7 Mounting

AV-Link is mounted in series between the AV-30-C and the AV-30-C backshell connector.

12.1.8 Removing AV-30-C From Instrument Panel (Optional)

It may be necessary, because of space limitations, to remove the AV-30-C unit for performing AV-Link installation. Using a Phillips screwdriver, remove the four [4] screws that attach the AV-30-C to the aircraft instrument panel. Pull unit down to a workable position. Note that it may also be necessary to disconnect the Pitot and Static lines to bring it into reach. Ensure that the lines are properly labeled before disconnecting.

12.1.9 AV-30-C Backshell Connector Removal

Using a flat screwdriver, loosen the two [2] screws that hold the backshell connector to the DB-15 connector on the back of the AV-30-C until the backshell connector is free to detach from the AV-30-C. If present, leave the bonding/ground strap attached to the backshell connector.



Figure 19 - AV-Link Backshell Connector Removal

12.1.10 AV-Link Attachment

Do not attempt to remove the two [2] captive Jack Screws from the AV-Link housing. Attach AV-Link to the back of the AV-30-C by inserting the unit into the DB-15 connector on the back of the AV-30-C.

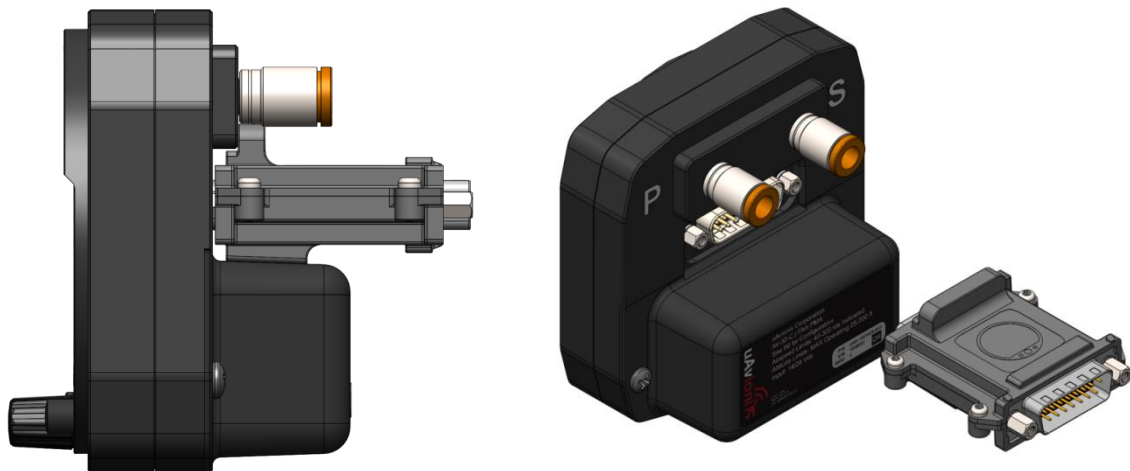

Figure 20 - AV-Link attachment

Do not push against the Jack Screws as they will stop against the screw bosses on the AV-30-C connector preventing proper seating of AV-Link. Also, make sure to seat AV-Link completely before tightening the Jack Screws.

Do not attempt to use the Jack Screws to pull AV-Link into the AV-30-C connector. AV-Link should seat firmly into the AV-30-C as shown in Figure 21.

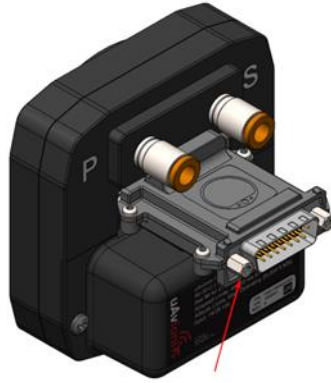

Figure 21- AV-Link installed

Using a 3/16” nut driver, tighten the two [2] Jack Screws to 5 in-lbs. maximum. Do Not Overtighten!

Reattach the original AV-30-C Backshell Connector. Using a flat screwdriver, tighten the two [2] screws to 5 in-lbs. maximum.

Do Not Overtighten!



Figure 22 - AV-Link attachment with backshell

12.1.11 AV-30-C Reinstallation in Instrument Panel

If the AV-30-C was removed from the aircraft instrument panel, reinstall the unit. If the original screws have been misplaced, please observe §11.6 Mounting Screw Length Restriction.

12.1.12 Continued Airworthiness

Maintenance of AV-Link is "on condition" only. Periodic regulatory function checks must be performed. The aircraft must be returned to service in a means acceptable to the appropriate aviation authority.

12.1.13 System Limitations

AV-Link is designed to supplement an AV-30-C. System limitations for AV-Link are determined by AV-30-C limitations.

12.1.14 Connecting to the AV-Link via Wi-Fi

As shipped from the factory, the AV-Link will function in default mode. However, to protect your AV-Link from unauthorized access and comply with SAIL A-1502, password protection must be enabled on the AV-Link's Wi-Fi network. To enable a password, change AV-Link settings, or apply firmware updates, the AV-Link may be accessed through a web browser, as described below.

Windows, MacOS, iOS and other devices are supported using the built-in web browser on your computer. To connect to the AV-Link through your browser, configure your computer for the AV-Link Wi-Fi connection.

1. Power AV-Link by attaching the AV-Link to AV-30-C to provide power.
2. Once the AV-Link is powered, on your computer, connect to the AV-Link Wi-Fi hotspot, which will have an "AV_XXXX" SSID, where XXXX is a combination of alpha-numeric characters.

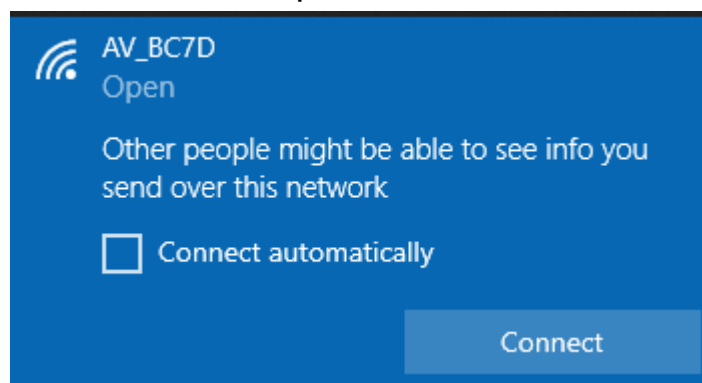

3. Once connected, use your web browser to navigate to 192.168.5.1 to view AV-Link settings.

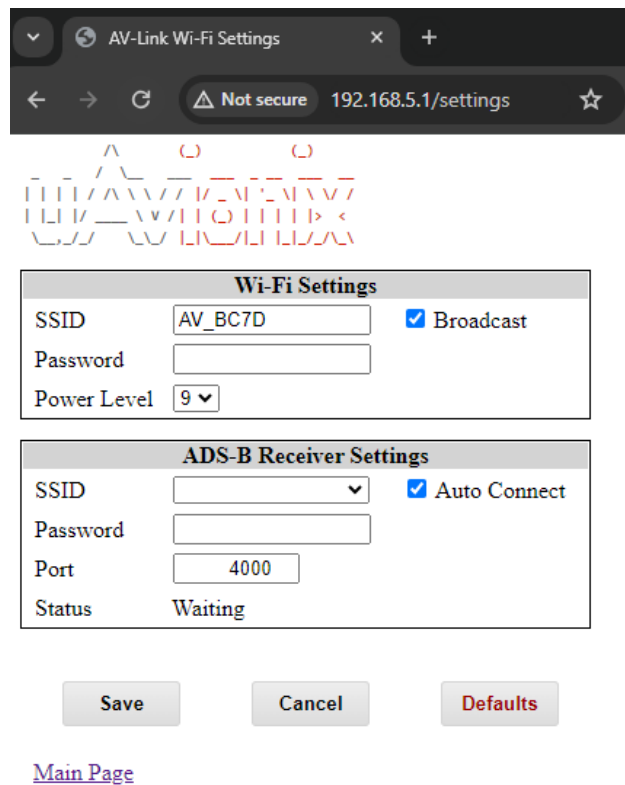

4. To set a password, select the Password box under “Wi-Fi Settings” and enter a combination of at least 8 letters, numbers, or symbols. Click Save. Record the password in your aircraft log book.

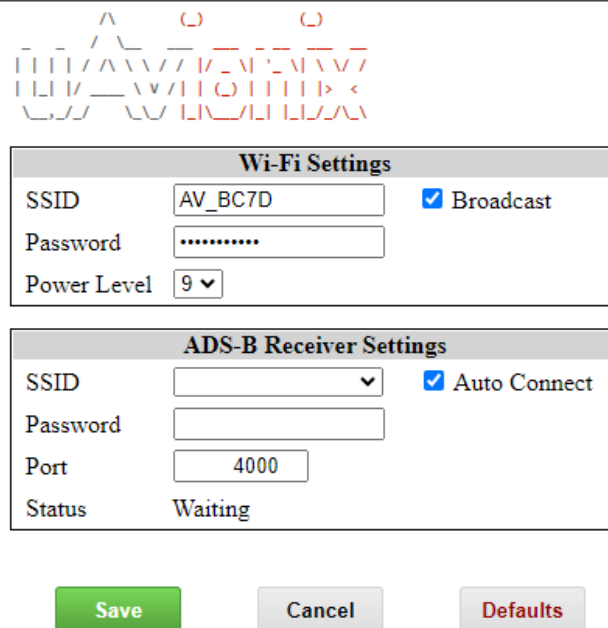

5. If the password was changed in the previous step, reconnect to the AV-Link's Wi-Fi network with the new password. Note that on some devices, the network SSID may appear with a number appended to it after adding a password.

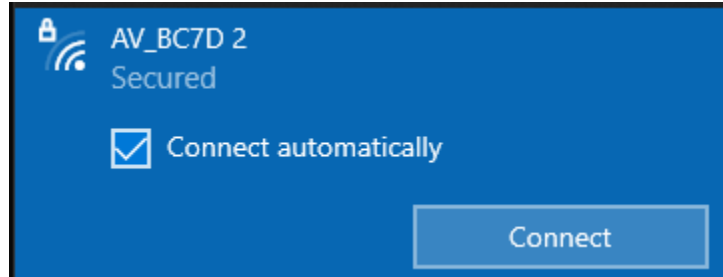

Refer to section 12.1.16 to reset the password or other settings.

12.1.15 Wi-Fi Firmware Update Page

Note: All settings changes should be performed while on the ground. Accessing the AV-Link web pages while in flight is not recommended and may disrupt normal operations of AV-30-C and AV-Link.

The AV-Link firmware update page permits firmware updating of AV-Link. Refer to the most recent service bulletin for the latest firmware update instructions.

12.1.16 AV-Link Factory Reset

The AV-Link can be returned to factory settings from the AV-30-C installation menu. For example, if the WiFi password was set but forgotten, the factory reset will delete the password. AV-Link software version 0.2.39 or later is required to support factory reset.

To execute factory reset, go to the AV-30-C installation menu item named "RESET AVLINK", select YES, then press and hold the right button until "COMPLETE" appears.

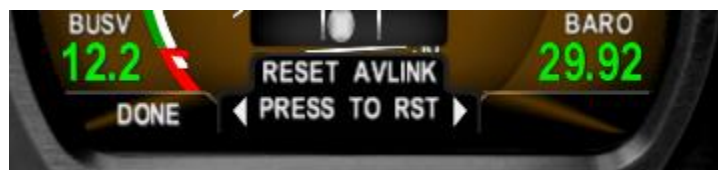



After completing the reset, a new WiFi password must be set using the steps detailed in 12.1.14.

12.2 Transponder (tailBeaconX)



For complete installation guidance, see *tailBeaconX TSO User and Installation Guide UAV-1004270-001* and *tailBeaconX STC Installation Manual UAV-1003599-001*.



For operation of tailBeaconX using the AV-30-C, see *AV-30-C Pilot's Guide UAV-1003946-001*.

tailBeaconX is a complete Mode S Extended Squitter (ES) ADS-B OUT transponder, integrated with an internal SBAS/WAAS GPS and all necessary antennas into an LED rear position light. tailBeaconX is designed to meet the transponder and ADS-B requirements for operating in controlled airspace worldwide, while minimizing installation costs.

tailBeaconX can optionally provide GPS information to the AV-30-C, including magnetic track and groundspeed.

For parallel connection of a tailBeaconX to two AV-30s, connect and configure the AV-30s according to Figure 23. Note that the tailBeaconX will only output GPS data when controlled by an AV-30. As diagrammed in Figure 23, the top AV-30 will only receive GPS data if the bottom AV-30 is powered on and configured properly.

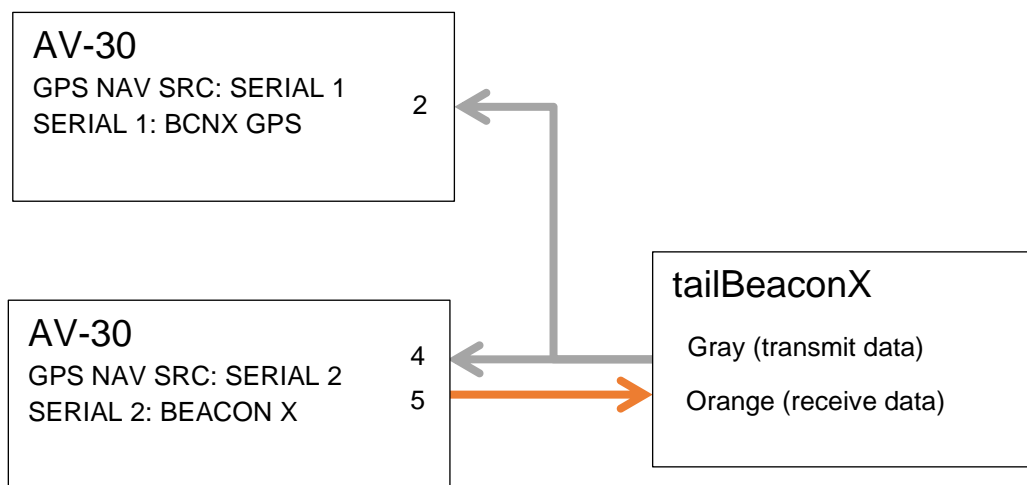

Figure 23 - Parallel tailBeaconX GPS Connections

12.2.1 Transponder Control

Transponder controls are enabled by selecting “BEACON X” on the “SERIAL 2” installation menu. See *AV-30-C Pilot’s Guide UAV-1003946-001* for transponder control information.

12.2.2 Transponder Testing with AV-30-C

Ground test mode may be initiated with from the AV-30-C via the following:

- Open the AV-30-C installation menu and select BEACONX GTM
- tailBeaconX will now respond to All-Calls on transponder test sets.
- When test is complete, cycle power.

12.3 AV-Mag External Magnetometer

12.3.1 Magnetometer Overview

AV-Mag external magnetometer (P/N UAV-1006518-001) is a 3-axis electronic compass. It can precisely measure the earth’s magnetic field and aid the AV-30-C gyroscopic heading measurement, improving long-term accuracy.

The AV-Mag improves accuracy of the gyroscopic direction indication of the AV-30-C. It is not a certified replacement for a required wet or dry compass.

For the AV-Mag to be effective, the installation and calibration must be done with accuracy and precision.

12.3.2 System Function

The AV-Mag, when paired with an AV-30-C, can provide consistent and accurate heading. The AV-Mag is an aiding device and does not provide full slaving to the AV-30-C.

12.3.3 AV-Mag Specifications

Table 3 - AV-Mag Specifications

Characteristics	Specifications
Part Number	UAV-1006518-001
Width	1.49 Inches
Height	0.67 Inches
Depth	2.38 Inches
Weight	1.4 oz (40.0 grams)
Operating temperature range	-40°C to +70°C
Maximum pressure altitude	35,000 ft
Input voltage range	7 VDC typical (from AV-30-C auxiliary power output)
7V current	12 mA typical

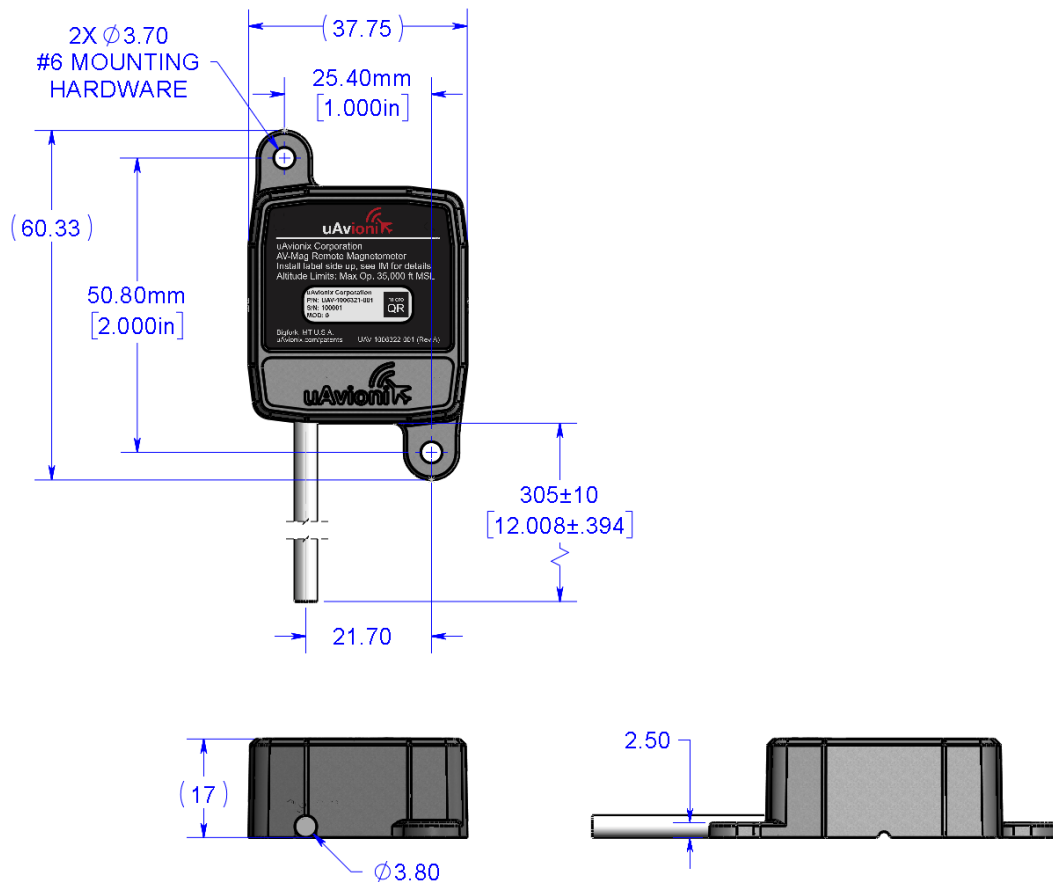

Figure 24 - AV-Mag Mechanical Drawing

Table 4 AV-Mag Wiring Guide

Wire	Function	AV-30-C pin
Red	+7 VDC Power	13
Black	Ground	10
Brown	Tx Data (AV-Mag → AV-30-C)	6
Green	Reserved serial input	NC
Blue	Reserved serial output	NC
White	Reserved serial input	NC

12.3.4 AV-Mag Software

The software contained in the AV-Mag device is identified by electronic marking. Software identification information is sent in a serial message after power-up. The software part number and software version can be verified via the installation menu of the AV-30-C (Table 13). The first screen of the AV-Mag installation menu also shows the current AV-Mag software version and CRC (see §12.3.8). If AV-Mag is not properly connected, the version will indicate 'N/A' or 'Not detected'.

12.3.5 AV-Mag Installation Overview

An overview of the installation process is provided below. Further detail for the process may be found starting in §12.3.8.

1. Configure the AV-30-C
 - a. In the AV-30-C installation menu, set SERIAL 4 to AVMAG to enable the AV-Mag.
 - b. Enter the AV-Mag installation sub-menu (AVMAG INSTL) found in the AV-30-C installation menu.
2. Wire and mount the AV-Mag
 - a. Identify a potential mounting location in the tail or wings.
 - b. Run wires from the AV-30-C to the mounting location and connect to the AV-Mag.
 - c. Check the mounting location for magnetic interference using the interference monitor in the AVMAG INSTL menu.

- If magnetic interference is excessive at the mounting location, select a different mounting location.
 - d. Mount and align the AV-Mag using brass screws.
 - e. Enter the orientation of the AV-Mag into the AV-30-C.
 - f. Adjust AV-Mag mounting angles to match AV-30-C mounting angles as displayed on the AV-30-C.
 - If necessary, build a bracket for the AV-Mag for mounting in the correct orientation and alignment.
 - AV-Mags can report their own roll and pitch angles to the AV-30-C. Those angles are visible on the second to last screen of the AV-Mag installation
3. Perform AV-Mag Calibration
- a. Run a calibration procedure on the installed AV-Mag and AV-30-C pair.
 - b. Perform a final check of heading. If all headings are off by a constant amount, use the DG adjustment to compensate.

Record your work in the provided tables and aircraft log book.

12.3.6 AV-Mag Installation Materials and Tools

AV-Mag installation requires access to these tools:

- Non-magnetic Screwdriver and wrench
- Fish tape for pulling wire from cockpit through wing structures
- Drill and drill bit
- Brass fasteners
- (Optional) Non-magnetic digital level or digital protractor/angle gauge. For example: Johnson Level & Tool 1886-0000
Magnetic Digital Angle Locator (unscrew the back of the case to remove the built-in magnets)

12.3.7 Additional Required Equipment

AV-Mag is designed to interface with an existing AV-30-C display.

12.3.8 Enable the AV-Mag

Use of the AV-Mag is enabled through the AV-30-C installation menu.

Before applying power, push and hold the center rotary knob and apply power. As the AV-30-C splash screen appears, check that a minimum version of 2.3.9 is displayed. AV-Mag support is not available in software versions prior to 2.3.9.

Enter the AV-30-C installation menu and navigate to the serial 4 interface option (SERIAL 4). Set SERIAL 4 to AVMAG.



While SERIAL 4 is set to AVMAG, the AHRS aiding mode (AID MODE) will automatically be set to AVMAG and cannot be changed.



Enter the AV-30-C installation menu again and navigate to the AV-Mag installation menu (AVMAG INSTL). Push the center rotary knob, then press the right button to begin the installation process. If AV-Mag is not properly connected, the version will indicate 'Not detected'.

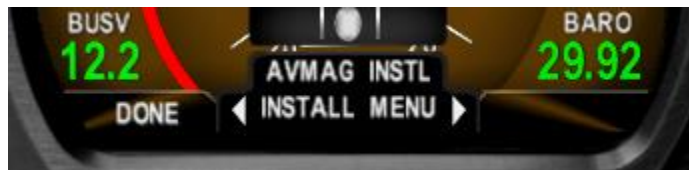



12.3.9 AV-Mag Installation Location and Interference Monitor

Identify a mounting location on the aircraft. Suitable mounting locations include the tail and either wing. The cockpit is an unsuitable mounting location for the AV-Mag.

Proximity to ferrous materials and current-generated magnetic fields can negatively affect AV-Mag performance. Avionics, engines, wing spars, pitot heaters, lights, etc. are all potential sources of interference. Any interference which varies during flight may generate erroneous headings from the AV-Mag. Because of this, the installation location should be as far as practical from these types of interferers. Inspect existing wiring near the installation location and repair or refresh any deteriorated insulation or corroded connections. Because wire loops generate magnetic fields, avoid locations near wires forming physical loops.

The fourth screen of the AVMAG INSTL menu is a magnetic field interference monitor with a checklist of aircraft systems which may be sources of interference.



Use the rotary knob to step through each system in the checklist and monitor the magnetic field deviation value.



The deviation value indicates the magnitude and direction of the magnetic reading with respect to the Earth's magnetic field. A relatively small deviation near zero indicates little or no magnetic field interference, while a larger negative or positive deviation indicates the AV-Mag is sensing magnetic fields in addition to the Earth's.

At the end of the checklist, a REVIEW screen identifies which systems caused the largest deviations. Identifying systems that cause interference, especially those that generate temporary magnetic fields, can aid in proper site selection for installing the AV-Mag. The interference range indicates fluctuating magnetic fields which will negatively impact calculated magnetic heading values, so a good installation requires this range to be as small as possible. If the range is greater than 10%, attempts should be made to re-site the AV-Mag location or to mitigate interferers.



12.3.10 AV-Mag Installation Orientation and Attitude

The AV-Mag can be installed in several orientations. The chosen installation orientation must be entered into the fifth page of the AVMAG INSTL menu according to Table 5. Figure 25 depicts the label and wire directions referenced in the table.



Table 5 - AV-Mag Orientation Options

Menu Option	Label direction	Wire direction
LUP+WAFT	Upward (facing up)	Toward tail (wires aft)
LUP+WFOR	Upward	Toward nose (wires fore)
LUP+WLT	Upward	Toward left wingtip (wires port)
LUP+WRT	Upward	Toward right wingtip (wires starboard)
LDN+WAFT	Downward (facing down)	Toward tail
LDN+WFOR	Downward	Toward nose
LDN+WLT	Downward	Toward left wingtip
LDN+WRT	Downward	Toward right wingtip
LRT+WAFT	Right wingtip (facing starboard)	Toward tail
LRT+WFOR	Right wingtip	Toward nose
LRT+WUP	Right wingtip	Toward sky (wires upward)
LRT+WDN	Right wingtip	Toward ground (wires downward)
LLT+WAFT	Left wingtip (facing port)	Toward tail
LLT+WFOR	Left wingtip	Toward nose
LLT+WUP	Left wingtip	Toward sky
LLT+WDN	Left wingtip	Toward ground
LFOR+WUP	Forward (facing nose)	Toward sky
LFOR+WDN	Forward	Toward ground
LFOR+WLT	Forward	Toward left wingtip
LFOR+WRT	Forward	Toward right wingtip
LAFT+WUP	Aft (facing tail)	Toward sky
LAFT+WDN	Aft	Toward ground
LAFT+WLT	Aft	Toward left wingtip
LAFT+WRT	Aft	Toward right wingtip



Figure 25 - AV-Mag Orientation Reference

In addition to the installation orientation, the mounting attitude of the AV-Mag must be determined as well. Though a small amount of angular mismatch between the installation attitudes of the AV-Mag and AV-30-C is tolerable, the AV-Mag is ideally installed with the same roll, pitch, and yaw as the AV-30-C.

To match angles of the two devices, reference the fourth page of the AVMAG INSTL menu, which displays the roll and pitch angles of the AV-30-C as mounted in the aircraft.

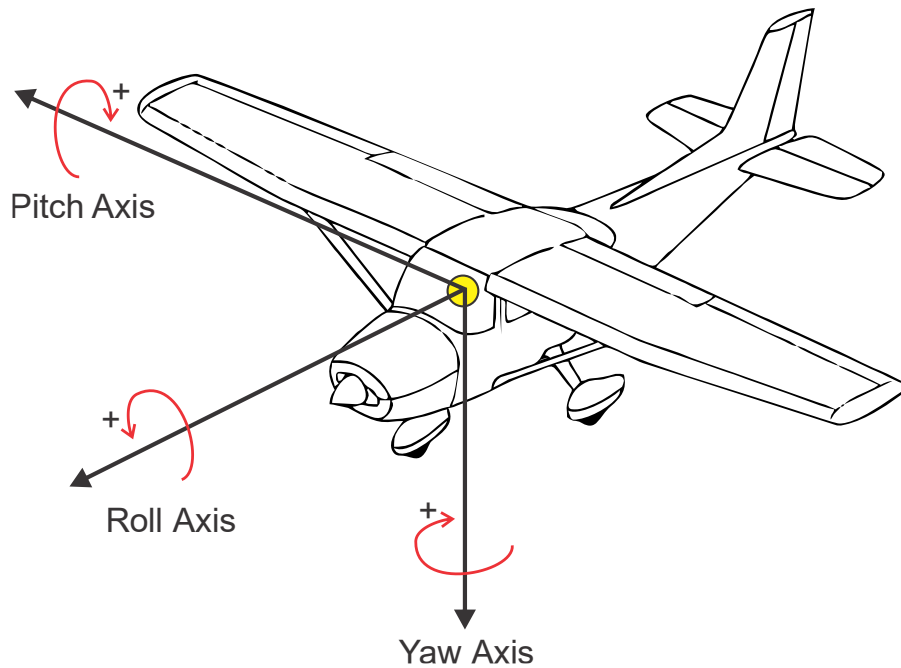

Adjust the AV-Mag mounting attitude to match that of the AV-30-C as closely as possible. Simultaneously, the AV-Mag should be oriented as parallel to the line of flight as possible.

The AV-30-C automatically measures the roll and pitch angles of the AV-Mag. Those angles are displayed on the SAVE screen. The AV-30-C will calculate the differences between AV-30-C and AV-Mag mounting angles for use in the heading solution.



After angles have been saved, calibration may begin. Record the installation selections and parameters in Table 8 of §14.2.3.



12.3.11 Calibration

Calibration is the process of detecting and compensating for minor magnetic field and ferrous material interferences coming from the aircraft. If the AV-Mag is relocated or is removed and reinstalled, a re-calibration must be performed. AV-Mag orientation, roll and pitch installation angles, and earth magnetic field values must be up-to-date at the time of calibration.

The calibration menu appears as AVMAG CAL in the AV-30-C installation menu. The calibration process requires the aircraft with AV-30-C and AV-Mag installed to be oriented to each of 12 headings, with a 10 second measurement time at each orientation. Any interfering systems that must be on during flight (e.g., navigation lights) must also be on during calibration.

When AV-Mag is connected in parallel to multiple AV-30-C, calibration must be completed on each connected AV-30-C. Calibrating multiple connected AV-30-C simultaneously is recommended.

Calibration is discussed in further detail in §14.2.3.

12.3.12 AV-Mag Yaw Angle

Please complete calibration of the AV-Mag prior to following the instructions of this section. Upon completion of calibration, the displayed heading at each of the 12 orientations should be checked and recorded in Table 9. If every heading is off by the same value, then the alignment of the aircraft to magnetic north may be imperfect. It is also possible that yaw angle of the installed AV-Mag may be imperfectly aligned with the aircraft line of flight.

Generally, the DG adjustment should be used to compensate for a constant heading offset and the AV-Mag Yaw Angle setting should be left at 0.0. If required, uAvionix technical support may direct you to change the Yaw Angle value.



12.4 AV-APA (Reserved)

12.5 Digital Autopilots (Reserved)

12.6 AV-HSI (Reserved)

13 Setup & Configuration

13.1 Startup and Common Controls

When powered on, the initial splash screen presents the company logo, unit model number, and the currently installed software version.



Figure 26 - Splash Screen

Operation in AI, DG, and MFD modes share common user interface controls as follows:

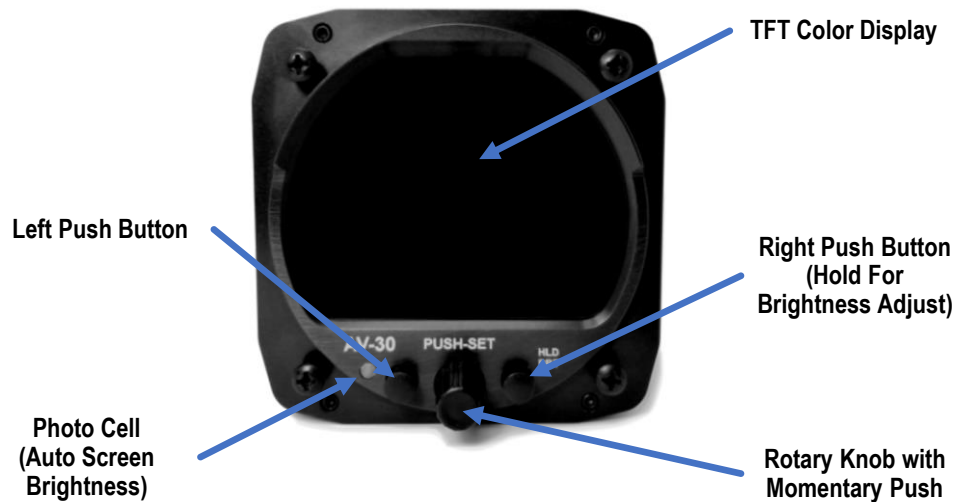

Figure 27 - Common User Interface Components

13.2 Available Menus

Setup and configuration menus are divided into three categories as follows:

- Edit Fields Menu (Pilot accessible)
- Setup Menu (Pilot accessible)
- Install Menu (Non-Pilot accessible)

The edit fields menu allows the pilot to configure the display to show the various supplemental parameters in the desired locations. Details of this are covered in *AV-30-C Pilots Guide UAV-1003946-001* and not addressed here.

The Setup Menu allows the pilot to set various configurations and alerting limits as desired for the type of operations being performed. These are also covered in the Pilot's Guide referenced above.

The installer may wish to pre-configure some or all these settings for the pilot, but the default settings are acceptable.



The Install Menu is for settings that are not normally required to be adjusted during flight. The installer must review and set these according to the installation configuration.

14 Installation Menu

The installation menu is used to configure the AV-30-C after installation and should only be accessed on the ground and changed by the installer.

To enable access the installation menu, ensure the unit is completely turned off. Press and hold the main control knob in while power is applied.



Figure 28 - Installation Menu Access

Keep the knob pressed until the startup logo has appeared. The installation menu will now be enabled for access but will not automatically appear on the screen.

Ensure the unit is in AI or DG mode; select the mode by pressing and holding the center button until the mode display changes. When in AI or DG mode, press and release the left MENU button three times until “INSTALL / ROT TO SEL” appears. The sequence of fields displayed is shown in Figure 29.



Figure 29 - Installation Menu Access

Rotating the knob left and right will access the various parameters that may be configured. Pressing the knob when the desired field is shown will allow the associated setting to be adjusted.

After adjustment, pressing the knob again will exit the editing mode but the installation menu will remain active.



Figure 30 - Exiting Edit Mode

Pressing DONE or a lack of user input for 30 seconds will exit the installation menu and return to the primary screen.



Figure 31 - Setup Done / Exit Option

Table 13 - Installation Menu Setting

Label	Description	Possible Values	Configured Value(s)
UNIT FUNCTION	Unit functionality	Set to default mode: AI* or DG	
FUNCTION LOCK	Functionality Lock	If locked, pilot may not change unit function	
PITCH TRIM ^[AI]	Pitch trim	Trim as needed: ± 27 Degrees (0*)	
ROLL TRIM ^[AI]	Roll trim	Trim as needed: ± 5 Degrees (0*)	
SLIP TRIM ^[AI]	Slip trim	Trim as needed: ± 5 Degrees (0*)	
OAT TRIM ^[AI]	OAT probe trim	Trim as needed: ± 200 (Unitless) (0*)	
SPD ASST ^[AI]	Speed Assist – use airspeed to assist attitude calculation	Yes* (on) or No (off)	
IAS TRIM LO ^[AI]	IAS trim at low speed	Trim as needed: ± 100 (in IAS UNITS) (0*)	
IAS TRIM HI ^[AI]	IAS trim at high speed	Trim as needed: ± 100 (in IAS UNITS) (0*)	
ALT TRIM LO	Barometric altitude trim	Trim as needed: ± 500 Feet	
ALT TRIM HI	Barometric altitude trim at value > 10,000' from ALT TRIM LO	Trim as needed: ± 500 Feet	
PITOT ZERO	Pressure sensor age compensation	Automatically determined by measurement	
AOA FUNC ^[AI]	Angle of Attack Alert	ENABLED*, DISABLED	
IAS UNITS ^[AI]	IAS display units	Knots* (KTS), Miles Per Hour (MPH), or Kilometers Per Hour (KPH)	
TAS UNITS ^[AI]	TAS display units	Knots* (KTS) , Miles Per Hour (MPH), or Kilometers Per Hour (KPH)	
IAS VSO ^[AI]	Stalling speed in landing configuration	Set to match limits: 40 to 555 (50*) in IAS UNITS	
IAS VS1 ^[AI]	Stalling speed in a specific configuration	Set to match limits: 40 to 555 (60*) in IAS UNITS	
IAS VFE ^[AI]	Maximum flap extended speed	Set to match limits: 40 to 555 (100*) in IAS UNITS	
IAS VNO ^[AI]	Maximum structural cruising speed	Set to match limits: 40 to 555 (150*) in IAS UNITS	
IAS VNE ^[AI]	Never exceed speed	Set to match limits: 40 to 555 (175*) in IAS UNITS	
IAS VMC ^[AI]	Minimum control airspeed with the critical engine inoperative	Set to match limits: 40 to 555 or disabled* in IAS UNITS	
IAS VYSE ^[AI]	Speed for best rate of climb OEI (single engine)	Set to match limits: 40 to 555 or disabled* in IAS UNITS	
BARO UNITS	Altimeter barometric units	Inches of Mercury* (INHG), millibars (MB), hectopascals (HPA)	
TEMP UNITS	OAT units	Celsius* (C) or Fahrenheit (F)	
GPS NAV SRC	Serial GPS format	NONE, SERIAL 1*, SERIAL 2	
SERIAL 1	GPS serial input	NONE, AV 9600*, NMEA 4800, NMEA 9600, BCNX GPS	
SERIAL 2	Auxiliary serial input	NONE*, BEACON X, AV-APA, AEROCRUZE, PRO PILOT	
SERIAL 3	System serial input	NONE, AVLINK*, EFIS, EFIS+AVLINK	

SERIAL 4	AV-Mag serial input	NONE*, AVMAG	
STATE SYNC	Synchronization of pilot settings across multiple AV-30 using AV-HSI or between an AV-30 and EFIS. – Not approved for certified aircraft	Source: None, AV-HSI*, EFIS Heading Bug: No, Yes* OBS: No, Yes* Set Altitude: No, Yes* Set Vertical Speed: No, Yes* Autopilot Mode: No, Yes* CDI Source: No, Yes* Baro Setting: No, Yes* OAT: No, Yes* DG: No, Yes* Alerts: No, Yes*	
AID MODE	AHRS aiding mode	NONE*, MAG1, MAG2, AVMAG	
AVMAG INSTL	AV-Mag Installation	See Table 14 for submenu description	
AVMAG CAL	Calibrates external magnetometer	Perform calibration after installation – only available for units with external magnetometer	
AVMAG YAW	AV-Mag installed Yaw angle trim	Trim as needed: ±15 Degrees (0*)	
MAG MONITOR	Magnetometer monitor	Push to view	
VIBE MONITOR	Vibration monitor	Push to view	
GYRO CAL	Calibrates aircraft gyros	Perform at installation or software update	
INT MAG CAL	Calibrates internal magnetometer	Perform in-flight calibration after installation – only available for units with internal magnetometer	
AV-APA CFG	AV-APA Configuration - Not approved for certified aircraft	NONE, S-TEC	
AV-APA THRU	AV-APA Serial Passthrough. Not approved or certified aircraft	NONE, BEACON X	
DEMO MODE	Demo mode	DISABLED*, MODE 1, MODE 2	
RESET AVLINK	Factory reset operation on attached AV-Link	Push to execute	
BEACONX GTM	BeaconX ground test mode	Push to execute	
SW PART NUM	Software part number	For reference	
SW VERSION	Software version	For reference	
SW CHECKSUM	Software checksum	For reference	
BL VERSION	Bootloader Version	For reference	
AVMAG SW PN	AV-Mag Software part number	For reference	
AVMAG SW VER	AV-Mag Software version	For reference	
AVAPA SW PN	AV-APA Software version – Not approved for certified aircraft	For reference	
AVAPA SW VER	AV-APA Software part number – Not approved for certified aircraft	For reference	
AVLINK SW PN	AV-Link Software part number	For reference	
AVLINK SW VER	AV-Link Software version	For reference	

BATTERY	Battery type	For reference	
SW CERT	Software certification	For reference	

[A] Available when Install Menu accessed through AI mode only

* Initial factory value

Table 14 - AV-Mag Submenu

Label	Description	Possible Values	Configured Value(s)
INTERFERENCE	Checklist of systems to exercise and monitor for excessive interference with the AV-Mag	LIGHTS, AVIONICS, CONTROLS, OTHER, ALL ON, REVIEW	
INSTL ORIENT	Orientation of the installed AV-Mag	See Table 5 for more details	
AV-30	Angles of the AV-30-C instrument in the stationary aircraft.	No user entry. Information for AV-Mag installation only. AV-Mag should be installed as closely as possible to the AV-30-C angles.	
ROLL ANGLE	Roll angle of the AV-Mag as mounted in the stationary aircraft	Automatically measured	
PITCH ANGLE	Pitch angle of the AV-Mag as mounted in the stationary aircraft	Automatically measured	
SAVE (Y/N)	Option to save changes to automatically measured roll and pitch angles	YES, Y/N?, NO.	
COMPLETE	Final screen of installation submenu. The next step of installation is to run the calibration procedure.	Information only	

* Initial factory value

14.1 Mandatory Settings

The following settings are mandatory for each installation.

14.1.1 Unit Function

- Set to AI if installation is replacing an existing Attitude Indicator.
- Set to DG if installation is replacing an existing Direction Indicator.
- Set to either when installation is as a non-required instrument. In this mode, this setting is the initial default operating mode if the function

lock below is not set to locked. With this setting, pilot may toggle mode.

14.1.2 Function Lock

Enable function lock for primary AI and DG installations. This prevents the pilot from toggling the operating mode.

Installation on a non-required instrument may be locked or not locked, based on owner preferences. Pressing and holding the center knob when functionality is not locked will toggle between AI, DG, and MFD modes.

14.1.3 Trim

Access to trim settings for various values can be accomplished by accessing the Install menu while in AI mode only.

- Set Pitch, Roll and Slip Trim to accommodate any mounting variations.
 - Accurate pitch, roll and slip trim is important to ensure optimal performance
- Set IAS and Altitude Trims to match existing instrumentation or test equipment as needed.

IAS and Altitude are factory calibrated to ensure accuracy.



Depending on installation or correspondence requirements, or to accommodate sensor aging, trimming of both functions can be achieved.

- Trim the OAT values to match that of a secondary temperature source such as ATIS.

14.1.4 Speed Assist

Use pitot-static data to improve attitude accuracy.

This setting should be set to Yes (enabled) unless this installation cannot meet required pitot-static connections and performance.

14.1.5 Angle of Attack

Angle of Attack alerts are enabled by default but may be disabled if desired.

14.1.6 V-Speeds

Set each of the V-Speeds to the values that correspond to the installation aircraft in knots.

14.1.7 Display Units

- Set the IAS units to match that of the existing airspeed indicator.
- Set the Baro units to match that of the existing altimeter.
- Set OAT units to owner / pilot preference.

14.1.8 Serial Inputs

GPS NAV SRC

Multiple serial ports support GPS sources. Set to the serial port on which your GPS source is installed.

Value	GPS Source
NONE	None available
SERIAL 1	Specified in SERIAL 1 setting
SERIAL 2	Specified in SERIAL 2 setting

SERIAL 1

This serial port corresponds to DB-15 pin 2. Set according to the type of the installed GPS navigator on this port.

Most handhelds are NMEA outputs while most panel mounted navigators are Aviation format. When allowed by installation, a tailBeaconX can also supply GPS input by selecting BCNX GPS.

Set to the corresponding GPS navigator input type.

Value	Serial 1 Source
NONE	None available
AV 9600	Aviation format (9600 bps)
NMEA 4800	NMEA format (4800 bps)
NMEA 9600	NMEA format (9600 bps)
BCNX GPS	tailBeaconX in receive only (parallel) mode, Only enable when authorized by separate approval

SERIAL 2

Set SERIAL 2 to NONE unless otherwise authorized.

Value	Serial 2 Source
NONE	No source available
BEACON X	tailBeaconX – Only enable when authorized by separate approval
AV-APA	Autopilot adapter – Do Not Enable unless authorized by follow-on approval
AEROCRUZE	AeroCruze 100 / xCruze 100 / TruTrak Vizion autopilot – Do Not Enable unless authorized by follow-on approval
PRO PILOT	Trio Pro Pilot – Do Not Enable unless authorized by follow-on approval

For parallel connection of a tailBeaconX to two AV-30-C, connect and configure the AV-30-C according to Figure 32 – Parallel tailBeaconX GPS Connections.

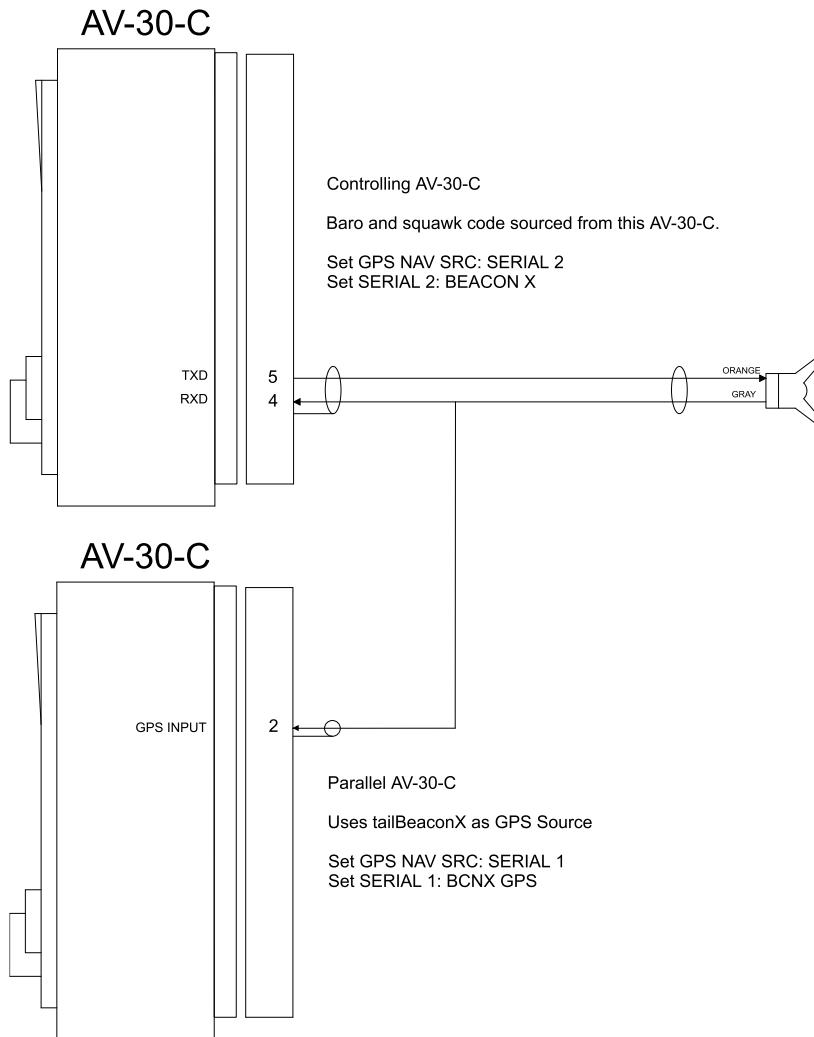

Figure 32 – Parallel tailBeaconX GPS Connections

SERIAL 3

Serial 3 is the system serial port. If using the AV-Link, set SERIAL 3 to AVLINK to enable MFD page.

Value	Serial 3 Source
NONE	No source available
AVLINK	AV-Link is installed, MFD enabled
EFIS	Connection to third-party EFIS. Do Not Enable unless authorized by follow-on approval
EFIS+AVLINK	Connection to a third-party EFIS with an AV-Link inline. Do Not Enable unless authorized by a follow-on approval

SERIAL 4

If using the AV-Mag, set SERIAL 4 to AVMAG to enable the external magnetometer aiding.

Value	Serial 4 Source
NONE	None available
AVMAG	AV-Mag is installed

14.1.9 AID Mode

Set AID MODE to NONE or AVMAG.

There are up to 3 options for the AID MODE, which controls the method of aiding the AHRS DG functionality.

Value	AHRS Aiding Source
NONE	None used
MAG1	Internal magnetometer provides correction data to DG – Do Not Enable unless authorized by follow-on approval
MAG2	Internal magnetometer provides correction data to DG and aiding to core AHRS algorithm – Do Not Enable unless authorized by follow-on approval
AVMAG	External magnetometer provides continuous heading data to DG and aiding to core AHRS algorithm. AV-Mag only.

Rotate the center knob until “AID MODE” is displayed. If the internal magnetometer is available (P/N UAV-1003429-002) then you will have a choice of NONE, MAG1, and MAG2. If the internal magnetometer is not found, only “NONE” will be displayed. If SERIAL 4 is set to AVMAG, AID MODE will be automatically set to AVMAG and is otherwise not settable.



Figure 33 - AID Mode Selection

Press the center knob and rotate to select your choice of Magnetometer aiding and then press the center button to confirm your choice.

14.1.10 Demo Mode

Set Demo Mode to DISABLED. Demo Mode will automatically be disabled when reaching an airspeed of 35 knots.

14.2 System Checkout

The following procedures must be performed prior to returning the aircraft to service.

14.2.1 Alignment

During initial startup, the ALIGN annunciator should be presented and flash. This indicates internal sensor stabilization is occurring. During the alignment, do not move the aircraft.

This should extinguish within 3 minutes, at which point valid attitude or direction indication is displayed.

If power is removed from the unit while it is still aligning the unit will go to battery mode until it has completed the alignment process.



Figure 34 - Aligning Annunciator

If the indicator is not extinguished within 3 minutes, reference the troubleshooting section of this document for additional information.

14.2.2 Gyro Calibration

As units age or experience unusual conditions, the precision gyroscopic sensors may need to be re-calibrated. This can be accomplished in the field using the procedure noted here. At least 15 minutes of warmup is required before performing the AV-30-C gyro calibration.

1. Before applying power, press and hold the center rotary knob and apply power. As the splash screen appears, check that a minimum version of 2.1.2 is displayed. Gyro Calibration must be completed on all units with software version 2.1.2 or later.
2. With the AV-30-C in the AI mode, enter the “Install Menu” page by pressing and releasing the left button repeatedly until the 3rd menu is displayed. The aircraft must be on the ground with no movement.



Figure 35 - Install Mode Selection

3. **It is critical to ensure the aircraft is completely motionless** and on the ground during the next several steps. The aircraft should be in a hangar and must not be affected by wind or other sources of aircraft movement. **Do not leave the aircraft during the countdown.**
4. Rotate the “Install Menu” to “GYRO CAL” and press the center button to choose calibration. If sufficient warmup time has not elapsed, a “Not ready to calibrate” message and countdown will be indicated. Otherwise, initiate calibration by pressing the right button.



Figure 36 - Gyro Calibration Selection

5. “Calibration in progress” will be displayed with a percentage complete.



Figure 37 - Gyro Calibration Procedure

6. AV-30-C will indicate “Calibration successfully completed / Press DONE”.

Press the left button under “DONE” and the calibration will be complete. If an error is shown, repeat the calibration process.

14.2.3 On-Ground External Magnetometer Calibration

Prior to calibration, complete all installation and measurement steps from §12.3 AV-Mag External Magnetometer. Failure to complete all installation steps will result in an invalid calibration.

Units with an external magnetometer (P/N UAV-1006518-001) require an on-ground 12-point magnetic calibration procedure to be performed. When calibration needs to be performed, in the absence of other flags, a red flag (MAG CAL) will appear.



Figure 38 – MAG CAL Flag and AVMAG CAL Selection

1. The external magnetometer calibration feature is found in the install menu. Hold down the center button while applying power. The installation menu can now be accessed until the next power cycle.
2. Move the aircraft to a location that is as level as possible and is far from power lines, metal structures, or reinforcement steel underground or nearby.
3. Enter the INSTALL menu and select AVMAG CAL, then press CALIB. Note that on units without an external magnetometer, AVMAG CAL will be disabled.



Figure 39 – AVMAG Calibration Entry



The aircraft will need to be oriented to twelve headings, each separated by 30 degrees. Calibration is sensitive to the angle between each of the heading orientations; if an accurate airfield compass rose is not available, measurements for each turn can be obtained using a calibrated magnetic compass or an electro-mechanical gyro. The AV-30-C will also provide an on-screen turning guide to each calibration point.

4. Follow the on-screen instructions, pressing the right button once the aircraft is oriented to heading 360. Keep the aircraft as motionless as possible while the “Calibration in progress” message is displayed.



Figure 40 – AVMAG CAL In-Progress

- Repeat step 4 for each orientation as directed by the on-screen instructions. The bottom-center display indicates the degrees and direction to the next orientation and will turn green when the aircraft is oriented correctly.



Figure 41 – AVMAG CAL Orientation Guide

- Upon completion, the raw data will be processed. If a good calibration is possible, the red MAG CAL flag will extinguish and the screen shall

display a success message. If the calibration failed, please review the procedure and execute it again.



Figure 42 – AVMAG CAL Success and Failure Screens

The AV-30-C will retain all magnetometer calibration data even if a hard reset is executed. Internal magnetometer and external magnetometer calibration data are stored independently.

Table 8 AV-Mag Installation Parameters

Parameter	Value
Installation Location on Aircraft	
AV-Mag Orientation	
Interference Range	
Max Interferer	
Min Interferer	
AV-30-C Roll Angle	
AV-30-C Pitch Angle	
AV-Mag Roll Angle	
AV-Mag Pitch Angle	
AV-Mag Yaw Angle (post-calibration)	

Table 9 – Calibrated Heading Check

Magnetic Heading	AV-30-C+AV-Mag Reported Heading	Magnetic Heading	AV-30-C+AV-Mag Reported Heading
0		180	
30		210	
60		240	
90		270	
120		300	
150		330	

14.2.4 OAT Interface

If an Outside Air Temperature (OAT) probe is connected, utilize the display customization guidance provided in the Pilot’s Guide to configure the display to show OAT in at least one textual display field.



Figure 43 - OAT Indicator

Note that OAT calibration is performed in the Setup procedures. This step only ensures that the OAT probe is detected properly.

14.2.5 GPS Navigator Interface

If a GPS Navigator is connected, utilize the display customization guidance provided in the Pilot's Guide to configure the display to show GPS navigational data in at least one textual display field.

The image below shows a typical configuration that the pilot may setup.



Figure 44 - GPS Data Elements

On the GPS navigator, set a destination waypoint and initiate a direct-to sequence. Note that not all navigators will output serial data until a waypoint has been selected and navigation initiated.

14.2.6 Vibration Check

Prior to flight, a vibration check **must** be completed. The vibration check helps ensure the vibration characteristics of the aircraft and installation

are suitable for use. The check procedure is performed during an engine run-up.

1. Before applying power to the AV-30-C, press and hold the center rotary knob and apply power. As the splash screen appears, check that a minimum version of 2.1.2 is displayed.
2. Enter the “Install Menu” page by pressing and releasing the left button repeatedly until the 3rd menu is displayed.
3. Rotate to “VIBE MONITOR” and press the center button.



Figure 45 - Vibe Monitor Selection

4. The Vibration Monitor will display current and peak values for the Accelerometer and Gyroscope.



Figure 46 - Vibe Monitor Operation

5. Perform an engine run-up, slowly increase engine power from idle to full and back to idle.
6. Record the peak values observed for both the Accelerometer and Gyroscope.

Peak values for the Accelerometer should not exceed **110**, and for the Gyroscope should not exceed **40**. If excessive values are observed, vibration must be mitigated to ensure expected performance. Consider the following:

- Ensure proper propeller balance. Perform dynamic propeller balancing.
- Replace worn engine mounts and address causes of high engine vibration.
- Ensure the AV-30-C is not mounted in a location subject to high vibration. This can often be detected by placing your hand on various locations in the panel, and can be caused by poorly supported panel regions, adjacent equipment, or proximity to engine structure.
- On isolated panels, replace the grommets; concurrently, ensure isolated panels have a ground strap.
- Ensure all mounting hardware is firmly attached.
- Check for rub marks on the AV-30-C case.
- Ensure connectors are firmly attached, and all cabling is firmly supported and not causing undue flex. The cabling must not be hitting or close to a moving surface (e.g. control yoke).

14.2.7 Air Data - Pitot Zero

Airspeed is computed by measuring the pressure differential between the Pitot and Static connections on the AV-30-C. Variation in installation and uneven aging of the pressure sensors may require field adjustment to maintain accuracy.

This Pitot Zero procedure must be performed on a new installation.

Additionally, the procedure should be performed every 24 calendar months as recommended or required by the AV-30-C Instructions for Continued Airworthiness, UAV-1004045-001.

The PITOT ZERO function is available in the installation menu.



To execute the PITOT ZERO function, go to the AI mode screen, go to the AV-30-C installation menu and select PITOT ZERO. Your pitot tube must be uncovered and the aircraft must be in a still air environment. Press and release the right button. If the measurement was successful a message stating “Measurement Complete P-S Difference 0.x” will appear. Press and release the left button or the center knob to exit. If the measurement failed a message stating “Measurement Failed” will appear. Check the measurement conditions and try again. If the function still fails, please contact product support.

14.2.8 Air Data - Altitude Trim

As the AV-30-C ages or is exposed to unusual conditions, the pressure sensors may require field adjustment to maintain accuracy. If the Altitude appears to be accurate at some altitudes and increasingly inaccurate as you increase or decrease altitude, a trim adjustment may be beneficial. This function requires a calibrated air data test set connected to the AV-30-C to simulate multiple altitudes.

To execute this function, go to the AI mode page on the AV-30-V and set the barometric pressure to 29.92. Now go to the installation menu and select ALT TRIM LO. Set the air data test set at a low altitude point somewhere between -1,000' and 14,900'. Press and release the center knob then turn the knob until the value displayed for BaroCorrAlt + Trim: is equal to the altitude on the air data test set. Press and release the center knob to exit the menu.



Now increase the altitude on the air data test set to a value at least 10,000' feet higher than the low altitude. Go to the ALT TRIM HI menu item. If the AV-30 perceives the altitude difference to be less than 10,000', ALT TRIM HI will be grayed out and un-selectable. If that is the case, keep increasing the altitude until ALT TRIM HI turns from gray to white. Press and release the center knob then turn the knob until the value displayed for BaroCorrAlt + Trim: is equal to the altitude on the air data test set. Press and release the center knob to exit the menu.

Record the ALT TRIM LO and ALT TRIM HI values in the aircraft records.

14.2.9 Air Data – IAS Trim

As the AV-30-C ages or is exposed to unusual conditions, the pressure sensors may require field adjustment to maintain accuracy. If the

indicated air speed appears to be accurate at some airspeeds and increasingly inaccurate as airspeed increases or decreases, a trim adjustment may be beneficial. This function requires a calibrated air data test set connected to the AV-30-C to simulate multiple airspeeds.

To execute this function, select the AI Mode on the AV-30-C. Go to the installation menu and select IAS TRIM LO. Set the air data test set to 45 knots or the stall speed or your aircraft, whichever is greater. Press and release the center knob then turn the knob until the airspeed displayed on the AV-30-C is equal to the airspeed indicated on the test set. Press and release the center knob to set.



Now increase the airspeed on the air data test set to a value at least 70 knots higher than the airspeed used to set the LO trim point. Using your aircraft's high-speed cruise airspeed is recommended. Go to the IAS TRIM HI menu item. If the AV-30-C perceives the airspeed difference to be less than 70 knots more than the speed used to set the LO trim, IAS TRIM HI will be grayed out and un-selectable. If that is the case, keep increasing the IAS on the test set until IAS TRIM HI turns from gray to white. Press and release the center knob then turn the knob until the IAS displayed is equal to the IAS on the air data test set. Press and release the center knob to exit the menu.

Record the IAS TRIM LO and IAS TRIM HI values in the aircraft records.

14.2.10 AV-APA Checkout (Reserved)

14.2.11 EMC Checkout

An EMC check should be performed after the AV-30-C installation is complete. The EMC check verifies that the newly installed equipment is not producing interference to other avionics and that the existing

avionics are not producing interference to the AV-30-C. The testing assumes the AV-30-C operational check has been completed and that the installed avionics to be tested are all in working condition.

1. Power on all avionics except the AV-30-C.
2. Verify all existing avionics are functioning properly. Some systems may require startup messages to be acknowledged/cleared to verify proper function.
3. After confirming all existing avionics are functioning properly, power off all existing equipment.
4. Power on the AV-30-C and perform the following tests as they apply to the existing aircraft equipment.
5. Observe load shedding procedures as appropriate for the aircraft during testing to ensure adequate power to complete the testing while maintaining enough reserve to support pre-flight and engine start.

VHF COM RADIOS

Verify AV-30-C operates without interference from the VHF COM operation.

1. Power on the VHF COM radio.
2. Transmit on a low, medium, and high frequency. Unused frequencies are recommended for this test. Example frequencies: 118.0, 126.0, and 135.0 Mhz.
3. During each transmission verify the AV-30-C continues to operate properly.

Verify each radio operates without interference from the AV-30-C.

1. Monitor a local frequency and verify there are no unintended squelch breaks or other tones that would interfere with communications.
2. Monitor a remote (distant) frequency and verify there are no unintended squelch breaks or other tones that would interfere with communications.
3. Monitor an unused frequency and verify there are no unintended squelch breaks or other tones that would interfere with communications.

VHF NAV RADIOS

Verify VHF NAV operates without interference from the AV-30-C.

1. Power on the VHF NAV radio.
2. Monitor a local, remote, and unused frequency.
3. Verify there are no misleading navigation indications during the monitoring of each frequency.
4. Verify audible station ID and that the station is clear of audio interference that would prevent identification.

ADDITIONAL AVIONICS

Additional Avionics should be tested according to the manufacturer EMC/EMI test procedures. This testing assumes the existing equipment is functional and operating correctly at time of testing. The following summarizes a typical EMC test.

1. Operate the AV-30-C.
2. Operate the existing installed avionics according to manufacturer instructions. If capable, utilize the device transmit and receive functions through a range of values.
3. Verify no errors, warnings, or unexpected operation is observed on the AV-30-C during operation of the installed avionics.
4. Verify no errors, warnings, or unexpected operation is observed on the installed avionics during operation of the AV-30-C.

15 Troubleshooting

The following steps are to aid in identifying installation or unit performance related issues:

Table 17 – Troubleshooting

Issue	Possible Reason
Power	
Unit does not power-on	Check associated breakers
	Ensure aircraft battery is greater than 10 VDC
	Check wiring and pinouts
Unit will not shut off, even if power is removed	Ensure no pitot or static blockage or line kinks are present (locking pressure and airspeed indication over 40 knots)
Stabilization	
Unit will not stabilize and aligning annunciator remains on	Return to factory for service if unit does not align within 3 minutes of power-on
DG drifts more than 30 degrees per hour	Make sure you are running the newest software.
	Complete Gyro Cal
	Enable magnetometer aiding with AV-Mag external magnetometer – see §12.3.8
Unit flashes “NO MAG” on right side	Check that you have selected the intended internal or AV-Mag external magnetometer function.
	Check AV-Mag wiring for intermittent connection or poor grounding.
Unit flashes “MAG CAL” on the right side	Complete the Mag Calibration flight in §14.2.3 if using the external magnetometer.
Battery	
Battery indication shows FAIL	Contact uAvionix support
Trim	
Roll, Pitch or Slip show small but constant error	Ensure unit is level in panel (using a bubble level or similar)
	Set trim adjustment in Installation menu. See Installation Manual for instructions
Airspeed or Altitude shows small but constant error	Set trim adjustment in Installation menu. See Installation Manual for instructions
Interface	
GPS information is expected but does not show up in data overlays	Check GPS input is configured to match the connected GPS serial data type and speed.
	Set direction indication to GPS TRK
“NO DATA” is shown	Check interface cables and pinouts

"NO GPS" is shown	Check GPS input is configured to match the connected GPS serial data type and speed
Splash screen shows "ERROR: Problem with bootloader. Factory service required."	Contact uAvionix support
Splash screen shows "ERROR: PROV value check failure. Service required."	Contact uAvionix support
Splash screen shows "ERROR: F-CAL value check failure. Verify user calibration data."	Contact uAvionix support
Alerts	
Audio alerts not heard over the audio system	Check wiring and ensure alerts are enabled in the Setup menu
	Ensure unswitched input is available on the audio panel
	Verify volume setting is sufficiently high in the Setup menu
Nuisance alerts are generated	Ensure alerting limits are configured as desired in the Setup menu
	Disable any undesired alerting features in the Setup Menus.

16 Instructions for Continued Maintenance & Operation

See *AV-30-C Instructions for Continued Airworthiness UAV-1004045-001* (ICA) for replacement, inspection requirements and procedures.

The ICA addresses the following aspects of continued airworthiness:

- Visual Inspection Procedure
- Altimeter Test and Calibration
- Battery Test and Replacement Procedure

17 Aircraft Flight Manual Supplements

See *AV-30-C Flight Manual Supplement UAV-1004044-001* for normal, emergency and limitations as required by CFR §23.1581.

18 Serial Interface Specification

GPS serial input is compatible with the “Aviation” and NMEA serial protocols. Aviation protocol is 9600 Baud, No Parity, 8 Data Bits, 1 Stop bit. NMEA is either 4800 or 9600 Baud, No Parity, 8 Data Bits, 1 Stop Bit. BeaconX UCP is 2400 baud, No Parity, 8 Data Bits, 1 Stop Bit.

The packets received are as follows:

Table 18 – GPS Serial Specification

Parameter Name	Aviation Packet	NMEA Packet	BeaconX – UCP Transponder Status (v3)
GPS Track	“C” Packet	\$GPRMC, Field 8	Track Heading
GPS Ground Speed	“D” Packet	\$GPRMC, Field 7	Horizontal Velocity
Distance to Waypoint	“E” Packet	\$GPRMB, Field 10	N/A
Cross Track Error	“G” Packet	\$GPRMB, Field 2	N/A
Desired Track	“I” Packet	Computed	N/A
Waypoint ID	“K” Packet	\$GPRMB, Field 5	N/A
Bearing to Waypoint	“L” Packet	\$GPRMB, Field 11	N/A
Magnetic Variation	“Q” Packet	\$GPRMC, Field 10	N/A
Flight Plan	“w” Packet	\$GPRTE, \$GPWPL	N/A

19 Field Update Capability

The unit software can be field updated. Updating requires an in-line harness and Windows based PC, or the optional AV-Link accessory to be installed. Contact uAvionix support for additional information, or reference available Service Bulletins.

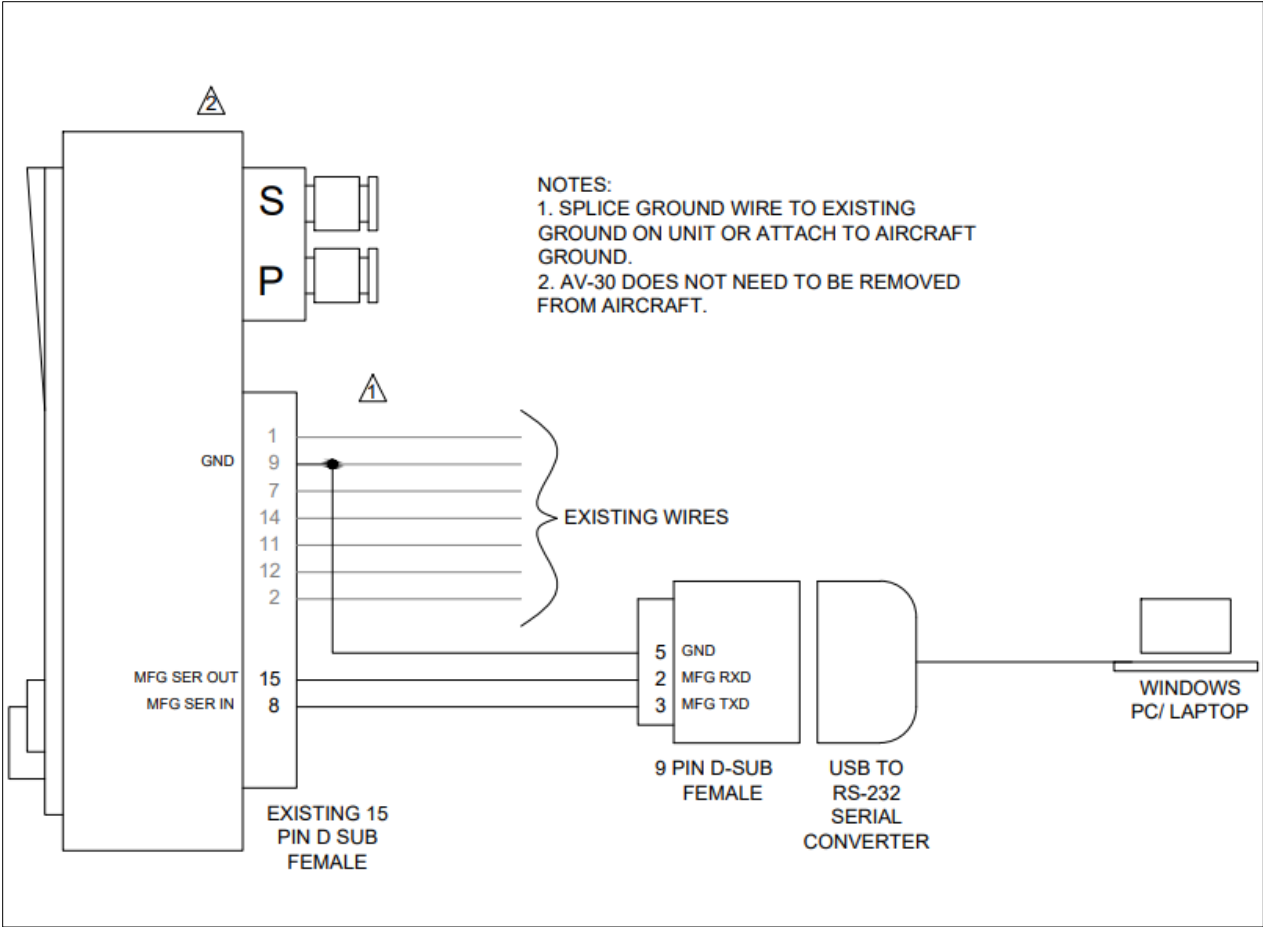

Figure 47 – Field Update Interface Diagram

20 Appendix A: Example Wiring Schematics

Below are a series of example wiring diagrams showing interconnection between a variety of uAvionix and third-party equipment. While these diagrams show common configurations, they do not enumerate all combinations or options. Extrapolation or interpolation between diagrams may be necessary.

Pitot-static connections are not depicted on these diagrams; however, they are necessary on all AV-30-Cs.

Configuration:
 - Single AV-30
 - Minimal Install

Install Menu:
 - Serial 1: NONE
 - Serial 2: NONE
 - Serial 3: NONE
 - Serial 4: NONE

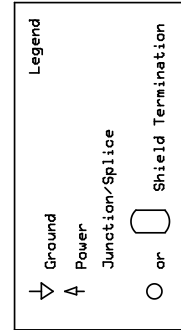
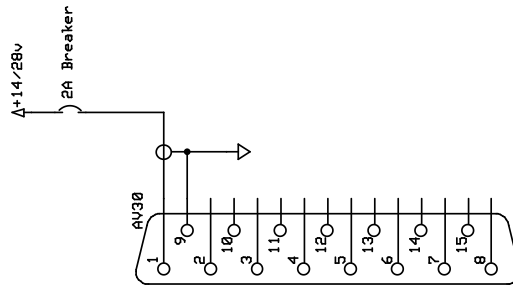

Notes:
 - Use M27500-22TG114 for Power
 - Terminate power shield at AV-30

uAvionix Corporation	
Single AV-30 CFG #1	
Example Wiring UAV-1007647-001	Rev. A 11/27/2023
Page 1 of 1	

- Configuration:
- Single AV-30
 - Serial (VFR Only) GPS - GPSMAP 296
 - tailBeaconX
 - OAT Probe
 - AV-MAG
 - Serial Update harnesses instead of AV-LINK

- Install Menu:
- GPS NAV SRC: SERIAL 1
 - Serial 1: NMEA 9600
 - Serial 2: BEACON X
 - Serial 3: NONE
 - Serial 4: AV-MAG

- GPSMap 296 Configuration
- COM 1
 - Serial Data Format : Aviation In/NMEA & VHF Out
 - Baud: 9600
 - Advanced NMEA Setup
 - Output Rate: Normal

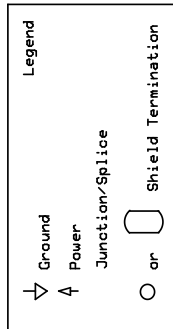
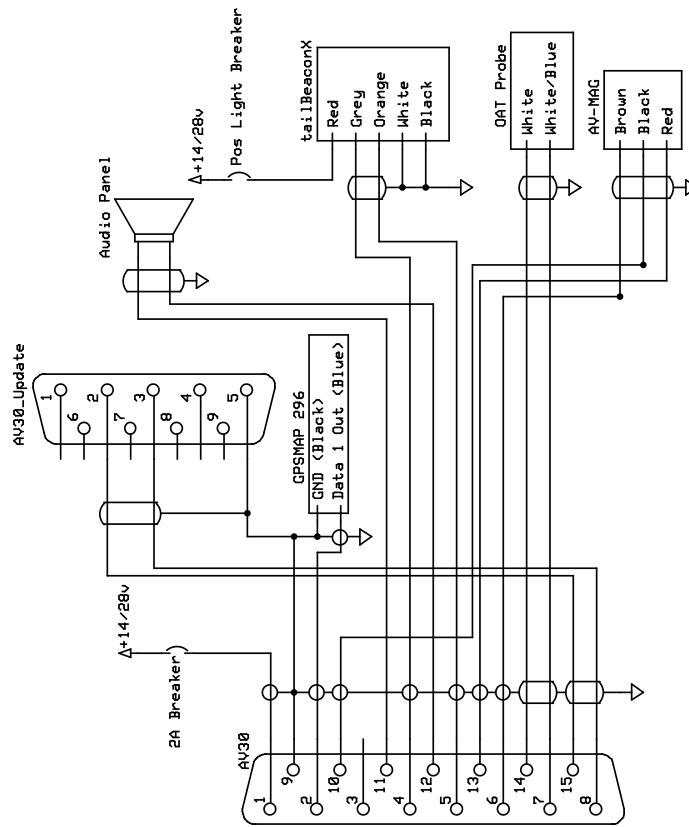

- Notes:
- Use M27500-22TGxT14 where x is the number of conductors
 - Terminate audio wire shield only at audio panel end
 - Terminate all other shields at both ends

Avionix Corporation	
Single AV-30 CFG #2	
Example Wiring UAV-1007647-002	Rev A 11/27/2023
Page 1 of 1	

