

AV-30-E

Installation Manual



Rev K
UAV-1004234-001

COPYRIGHT AND PRIVACY NOTICE

Except as expressly provided herein, no part of this guide may be reproduced, transmitted, disseminated, downloaded, or stored in any storage medium, for any purpose without the express written permission of uAvionix. uAvionix grants permissions to download a single copy of this guide onto an electronic storage medium to be viewed for personal use, provided that the complete text of this copyright notice is retained. Unauthorized commercial distribution of this manual or any revision hereto is strictly prohibited.

uAvionix® and Ping® are registered trademarks of uAvionix Corporation and may not be used without express permission of uAvionix.

AV-30, AV-30-E, AV-Link-E, AV-Mag, AV-APA, AV-HSI, Sentry, BeaconX, tailBeaconX, and skyBeaconX are trademarks of uAvionix Corporation and may not be used without express permission of uAvionix.

© 2020 - 2025 uAvionix Corporation. All rights reserved.

uAvionix Corporation
Bigfork, MT

General: www.uavionix.com
Support: support@uavionix.com
Patents: www.uavionix.com/patents

Warnings / Disclaimers

All device operational procedures must be learned on the ground.

uAvionix is not liable for damages arising from the use or misuse of this product.

This equipment is classified by the United States Department of Commerce's Bureau of Industry and Security (BIS) as Export Control Classification Number (ECCN) 7A994.

These items are controlled by the U.S. Government and authorized for export only to the country of ultimate destination for use by the ultimate consignee or end-user(s) herein identified. They may not be resold, transferred, or otherwise disposed of, to any other country or to any person other than the authorized ultimate consignee or end-user(s), either in their original form or after being incorporated into other items, without first obtaining approval from the U.S. government or as otherwise authorized by U.S. law and regulations.

Limited Warranty

uAvionix products are warranted to be free from defects in material and workmanship for two years from the installation of AV-30-E on the aircraft. For the duration of the warranty period, uAvionix, at its sole option, will repair or replace any product which fails in normal use. Such repairs or replacement will be made at no charge to the customer for parts or labor, provided that the customer shall be responsible for any transportation cost.

Restrictions: This warranty does not apply to cosmetic damage, consumable parts, damage caused by accident, abuse, misuse, fire or flood, theft, damage caused by unauthorized servicing, or product that has been modified or altered.

Disclaimer of Warranty: IN NO EVENT, SHALL UAVIONIX BE LIABLE FOR ANY INCIDENTAL, SPECIAL, INDIRECT OR CONSEQUENTIAL DAMAGES, WHETHER RESULTING FROM THE USE, MISUSE, OR INABILITY TO USE THE PRODUCT OR FROM DEFECTS IN THE PRODUCT. SOME STATES DO NOT ALLOW THE EXCLUSION OF INCIDENTAL OR CONSEQUENTIAL DAMAGES, SO THE ABOVE LIMITATIONS MAY NOT APPLY TO YOU.

Warranty Service: Warranty repair service shall be provided directly by uAvionix. Proof of purchase for the product from uAvionix or authorized reseller is required to obtain and better expedite warranty service.

Please email or call uAvionix support with a description of the problem you are experiencing. Also, please provide the model, serial number, shipping address and a daytime contact number.

You will be promptly contacted with further troubleshooting steps or return instructions. It is recommended to use a shipping method with tracking and insurance.

1 Revision History

Revision	Date	Comments
A	6/2/2020	Initial release
B	1/12/2021	Software update 1.1.0
C	7/22/2021	Software update 2.1.1 Added Transponder control Added AV-Link installation Added definition of acronyms & terms section Added magnetometer aiding and calibration Added requirement of pitot and static
D	1/5/2022	Added AeroCruze/TruTrak installation and control
E	4/12/2022	Added AV-Mag external magnetometer installation and calibration instructions
F	8/24/2022	Added AV-Link reset, Pitot-Zero, and Two-Point Altitude Trim to the installation menu. Changed TRUTRAK to AEROCRUZE. Added PRO PILOT to the Serial 2 selection menu. Added True Airspeed units selection (knots or mph). Refactored GPS Navigation source menu to include a parallel-connected BeaconX as a GPS input-only connection. Added Serial 1 selection menu. Add display of bootloader version number. Changed warning flag from "NO MAG" to "MAG CAL" when magnetometer calibration data is missing. Add AV-Mag software CRC display in the installation menu. Internal magnetometer calibration menu is now disabled if the AV-30 is configured to use an AV-Mag. Add AV-Mag wiring table. Add saved-setting integrity check alerts.
G	2/28/2023	Revised AV-Mag installation procedure to eliminate earth magnetic field and simplification for AV-Mag hardware that can measure its own installation angle.

		Updated AV-Link for latest version (0.3.0) and new IP (192.168.5.1).
H	12/7/2023	<p>Added AV-APA. Added AV-HSI Wiring. Updated AV-Link current draw. Updated installation kit. Added Appendix A – Example Wiring Diagrams Added Speed Assist. Added EFIS synchronization. Added multi-point IAS trim. Added hectopascals and KPH units. Added additional AV-Mag Orientations. Decomposed wiring diagrams to add clarity. Specified wire as MIL-C-27500. Updated Table 4 with new GPS sources supported by MFD Updated 12.1.10 to note that demo mode is automatically disabled at 35 kts. Updated Table 38 with waypoint packets. Updated 12.1.6 to indicate units match IAS UNITS. Updated 12.1.7 to indicate IAS UNITS applies to IAS V-Speeds, IAS TRIM, displayed GS, and displayed IAS. Clarified parallel tailBeaconX behavior in section 11.2 Update 11.6 to describe screw depth gauge</p>
I	4/5/2024	<p>Added RTCA DO293A and SAE AS6296 to Table 7-1. Updated Table 9-1 with Attitude Miscompare, Carbon Monoxide, Navigation Mode, AP Mode, and OBS overlays. Updated 9.2.2 to clarify requirement for Pitot and Static connections on all AV-30. Clarified BEACONX testing steps in section 11.2.2.</p>

		<p>Updated Section 11.4 to include ARINC 429 autopilots, GPSS capability, and Advanced Autopilot Unlock.</p> <p>Added AV-HSI Configuration, Ground, and Flight checkout procedures to section 11.5.</p> <p>Added AV-HSI, AV-APA, AV-MAG Troubleshooting steps to Section 14.</p> <p>Add Section 16, ARINC 429 Interface Specification.</p> <p>Updated example wiring diagrams to fix reverse wiring of OAT Probe.</p> <p>Updated example wiring diagrams to depict AV-HSI update harness.</p> <p>Added Dual AV-30 CFG 4 example wiring diagram to depict parallel tailBeaconX operation.</p> <p>Update screw depth guidance in section 10.6</p> <p>Update table 15-1 with Lat and Lon messages</p>
J	7/12/24	<p>Add Rate of Turn, Standard Rate Bank Angle, G-Max and G-Min, and Rate of Climb to 6.2 and Table 9-1.</p> <p>Update Table 6-1, Table 10-1, and 10.5 to include extended battery.</p> <p>Update Table 10-1 to latest software release.</p> <p>Update Figure 2 to show optional MFD/VSI.</p> <p>Add Serial 3 Configuration to AV-Link instructions in Section 11.1.12.</p> <p>Add AV-Link connected to AV-HSI configuration in Section 11.1.18, Table 11-13.</p> <p>Add ability to connect NMEA GPS to AV-HSI in Section 11.5.</p> <p>Updated Table 11-10, Figure 31, and Table 11-19 to include GNC-215.</p> <p>Updated Table 13-1 to include ability to disable unused pages.</p> <p>Added AV-HSI Submenu table 13-2.</p>

		<p>Updated Dual AV-30 CFG 3 Example Wiring Diagram to include Trio Pro Pilot Example.</p> <p>Updated Figure 29 to add clarity to parallel wiring of GPS and Autopilot.</p> <p>Added GPSS gain behavior to Table 13-1.</p> <p>Consolidated AV-Mag calibration instructions into Section 11.13.</p>
K	1/8/2025	<p>Global formatting updates.</p> <p>Update Figure 37 to new AV-HSI height.</p> <p>Clarify grounding in Figure 39 and Figure 40.</p> <p>Update example wiring diagrams to clarify grounds.</p> <p>Add Figure 36 showing ARINC switch.</p> <p>Update Figure 34 to list STEC 60-1, 65.</p>

2 Table of Contents

- COPYRIGHT AND PRIVACY NOTICE..... 2
- WARNINGS / DISCLAIMERS..... 3
- LIMITED WARRANTY 4
- 1 REVISION HISTORY 5
- 2 TABLE OF CONTENTS 9
- 3 INTRODUCTION..... 13
 - 3.1 PURPOSE..... 13
 - 3.2 DEFINITION OF ACRONYMS & TERMS..... 13
- 4 AV-30 SYSTEM INFORMATION 15
 - 4.1 SYSTEM DESCRIPTION..... 15
 - 4.2 SYSTEM FUNCTIONS..... 17
- 5 DESIGN STANDARDS 20
 - 5.1 APPLICABLE PERFORMANCE STANDARDS 21
- 6 INSTALLATION LIMITATIONS 22
- 7 INSTALLATION LOCATIONS & OPERATING MODES..... 23
 - 7.1 INSTALLATION LOCATIONS 23
 - 7.2 OPERATING MODE CONFIGURATION..... 23
- 8 FUNCTIONALITY AND REQUIRED INTERFACES 24
 - 8.1 AIRCRAFT SYSTEMS CONNECTIONS 24
 - 8.2 FEATURE MATRIX..... 25
 - 8.2.1 *Power Input (Required)* 27
 - 8.2.2 *Pitot and Static Interfaces (Required)* 27
 - 8.2.3 *Outside Air Temp Input (Optional)* 28
 - 8.2.4 *Audio Output (Optional)* 28
 - 8.2.5 *Navigation Interface (Optional)* 29
 - 8.2.6 *Internal Magnetometer (Optional)* 31
 - 8.2.7 *AV-Mag External Magnetometer (Optional)* 31
 - 8.2.8 *Transponder Control (Optional)* 31
 - 8.2.9 *AV-Link Interface (Optional)* 32
 - 8.2.10 *Autopilot Interfaces (Optional)* 32
 - 8.3 INTERNAL BATTERY OPERATION..... 33
 - 8.3.1 *General*..... 33
- 9 EQUIPMENT INSTALLATION 34

9.1	OVERVIEW	34
9.2	SUPPLIED COMPONENTS	34
9.3	NON-SUPPLIED COMPONENTS	36
9.4	INSTALLATION RECORDS.....	36
9.5	MECHANICAL DRAWING	36
9.6	MOUNTING THE AV-30	38
9.7	WIRING DIAGRAMS	43
9.8	BONDING REQUIREMENTS.....	47
9.9	UNIT PINOUT.....	49
10	OPTIONAL EQUIPMENT INSTALLATION	51
10.1	AV-LINK	51
10.1.1	System Function	51
10.1.2	FCC ID.....	51
10.1.3	AV-Link Specifications	51
10.1.4	AV-Link Software.....	53
10.1.5	AV-Link Installation Materials and Tools	53
10.1.6	Additional Required Equipment	53
10.1.7	Mounting	54
10.1.8	Removing AV-30 From Instrument Panel (Optional).....	54
10.1.9	AV-30 Backshell Connector Removal	54
10.1.10	AV-Link Attachment	55
10.1.11	AV-30 Reinstallation in Instrument Panel.....	57
10.1.12	AV-30 Configuration	57
10.1.13	System Limitations	57
10.1.14	Connecting to the AV-Link via Wi-Fi	57
10.1.15	Wi-Fi Firmware Update Page	58
10.1.16	AV-Link Factory Reset.....	58
10.1.17	Optional AV-Link Connected to AV-HSI.....	60
10.2	TRANSPONDER (TAILBEACONX)	62
10.2.1	Transponder Control	63
10.2.2	Transponder Testing with AV-30.....	64
10.3	AV-MAG EXTERNAL MAGNETOMETER	64
10.3.1	Magnetometer Overview.....	64
10.3.2	System Function	64
10.3.3	AV-Mag Specifications	64
10.3.4	AV-Mag Software.....	66
10.3.5	AV-Mag Installation Overview	67
10.3.6	AV-Mag Installation Materials and Tools	68
10.3.7	Additional Required Equipment	69
10.3.8	Enable the AV-Mag	69
10.3.9	(Section removed).....	70
10.3.10	AV-Mag Installation Location and Interference Monitor	70

10.3.11	AV-Mag Installation Orientation and Attitude.....	72
10.3.12	AV-Mag Calibration.....	77
10.3.13	AV-Mag Yaw Angle.....	81
10.4	AUTOPILOT OVERVIEW.....	81
10.4.1	AV-APA Analog Port Adapter.....	82
10.4.1.1	AV-APA Overview.....	82
10.4.1.2	AV-APA Specifications.....	84
10.4.1.3	AV-APA Installation Overview.....	87
10.4.1.4	AV-APA Installation Materials and Tools.....	88
10.4.1.5	Configure the AV-30 for the AV-APA.....	88
10.4.1.6	AV-APA Wiring and Autopilot Configuration.....	90
10.4.1.7	Ground Checkout.....	93
10.4.2	RS-232 Autopilots.....	93
10.4.2.1	RS-232 Autopilot Control.....	94
10.4.2.2	RS-232 Autopilot Ground Checkout.....	95
10.4.3	ARINC 429 Autopilots.....	101
10.4.3.1	ARINC 429 Autopilot Installation.....	101
10.4.4	Advanced Autopilot Unlock.....	104
10.5	AV-HSI HORIZONTAL SITUATION INDICATOR.....	106
10.5.1	AV-HSI Overview.....	106
10.5.2	AV-HSI Specifications.....	108
10.5.3	AV-HSI Installation Overview.....	111
10.5.4	AV-HSI Installation Materials and Tools.....	111
10.5.5	AV-HSI Wiring.....	112
10.5.6	AV-HSI Update Harness.....	116
10.5.7	AV-HSI/AV-30 Configuration.....	117
10.5.8	AV-HSI Ground Checkout.....	129
10.5.9	AV-HSI Flight Checkout.....	130
10.6	ELECTRONIC FLIGHT INSTRUMENT SYSTEM (EFIS).....	130
10.6.1	EFIS Overview.....	130
11	SETUP & CONFIGURATION.....	132
11.1	STARTUP AND COMMON CONTROLS.....	132
11.2	AVAILABLE MENUS.....	133
12	INSTALLATION MENU.....	135
12.1	MANDATORY SETTINGS.....	142
12.1.1	Unit Function.....	142
12.1.2	Function Lock.....	142
12.1.3	Trim.....	143
12.1.4	Speed Assist.....	143
12.1.5	Angle of Attack.....	143
12.1.6	V-Speeds.....	143
12.1.7	Display Units.....	143

12.1.8	Serial Inputs	144
12.1.9	AID Mode (Magnetometer)	146
12.1.10	Demo Mode.....	147
12.2	SYSTEM CHECKOUT	147
12.2.1	Alignment.....	148
12.2.2	Gyro Calibration	148
12.2.3	In-Flight Internal Magnetometer Calibration	151
12.2.4	AV-Mag Calibration Check	152
12.2.5	OAT Interface	154
12.2.6	GPS Navigator Interface.....	154
12.2.7	Vibration Check	155
12.2.8	Air Data – Pitot-Static Zero	157
12.2.9	Air Data – Altitude Trim	158
12.2.10	Air Data – IAS Trim	159
12.2.11	AV-APA Checkout	160
12.2.12	EMC Checkout	161
13	TROUBLESHOOTING	164
14	SERIAL INTERFACE SPECIFICATION	167
15	ARINC 429 INTERFACE SPECIFICATION	168
16	FIELD UPDATE CAPABILITY	170
17	APPENDIX A: EXAMPLE WIRING SCHEMATICS	171
18	LIST OF FIGURES	180
19	LIST OF TABLES	182

3 Introduction

3.1 Purpose

This installation manual applies to the following articles:

- AV-30-E (non-certified)
- AV-Mag
- AV-Link
- AV-APA
- AV-HSI

This manual is limited to equipment installed in non-certified aircraft. If installing equipment in a certified aircraft, use *UAV-1003947-001, AV-30-C Installation Manual*.

3.2 Definition of Acronyms & Terms

Acronym	Definition
ADS-B	Automatic Dependent Surveillance - Broadcast
AI	Attitude Indicator
AoA	Angle of Attack
AP	Autopilot
APA	Analog Port Adapter
ATIS	Automatic Terminal Information Service
BARO	Barometer; barometric
CDI	Course Deviation Indicator
CFI	Certified Flight Instructor
CFR	Code of Federal Regulation
CRC	Cyclic Redundancy Check
DALT	Density Altitude
DG	Directional Gyroscope
GPS	Global Positioning System
GPSS	Global Positioning System (GPS) Steering
HIRF	High-Intensity Radiated Field
IAS	Indicated Airspeed
ILS	Instrument Landing System

Acronym	Definition
IMC	Instrument Meteorological Conditions
MFD	Multi-Function Display
OAT	Outside Air Temperature
OBS	Omni-Bearing Selector
SALT	Selected Altitude or Set Altitude
SVS	Selected Vertical Speed or Set Vertical Speed
TAS	True Airspeed
TSO	Technical Standard Order
VOT	VOR Test Facility
VOR	VHF Omni-directional Range
V _{MC}	Minimum controllable airspeed
V _{YSE}	Best rate-of-climb speed with one engine inoperative
V _{SO}	Minimum stall speed with gear and full flaps. The bottom end of the ASI white arc.
V _{S1}	Minimum steady flight velocity while still controllable. The bottom end of the ASI green arc.
V _{FE}	Maximum flap extended velocity. The top end of the ASI white arc.
V _{NO}	Maximum normal operating velocity. The top end of the ASI green arc.
V _{NE}	Maximum velocity in smooth air (never exceed). The red line at the top end of the ASI yellow arc.
V _{MC}	Minimum control airspeed with the critical engine inoperative
V _{YSE}	Speed for best rate of climb OEI (single engine)

4 AV-30 System Information

This document provides instructions on the installation requirements for the uAvionix AV-30 multi-mode instrument.

4.1 System Description

The uAvionix AV-30 is a fully digital multi-mode instrument that mounts in the legacy 3-1/8" round instrument panel cutout typically found in light general aviation instrument panels. It can be field configured as either an Attitude Indicator (AI) or a Directional Gyro (DG) indicator, is fully self-contained with dual-precision inertial and pressure sensors and allows for a wide variety of pilot customization. With optional accessories, the AV-30 can also be configured as a Multi-Function Display (MFD) or Course Deviation Indicator (CDI).



Figure 1 – AV-30 Multi Mode AI/DG/MFD/Transponder – Basic Display

When configured as an AI, primary attitude and slip are always displayed. The unused portions of the display area can be customized by the pilot to show a variety of textual and graphical data-overlay fields. Up to three pages may be customized by the pilot while the last page presents a fully decluttered view of only attitude and slip or control of a compatible uAvionix ADS-B transponder such as the tailBeaconX.

When configured as a Directional Gyro (DG), non-slaved direction of flight information is presented. The non-slaved direction can be manually adjusted by pilot input or may be optionally slaved to GPS track. Multiple display presentations, including compass rose, GPS HSI, and GPS arc views can be selected by the pilot. The unused portions of the display area can similarly be configured for a variety of textual data overlays.

With an optional AV-Link accessory, the AV-30 can be configured as a Multi-Function Display (MFD) that displays traffic from ADS-B receivers. MFD and DG modes are accessible when the AV-30 is configured as a DG. As with other operating modes, the last page provides a reversionary AI.

With an optional AV-HSI accessory, the AV-30 can be configured as a Course Deviation Indicator (CDI). Two CDI pages are available, with the third providing a reversionary AI. As with other modes, unused portions of the display area can be configured with textual data overlays.

In all operating modes, the pilot may select from multiple visual styles which are intended to improve visual compatibility with legacy aircraft instrumentation and preserve the look-and-feel of older aircraft applications.

A wide variety of supplemental functions, including audio alerting, derived angle of attack presentation, g-load display, and more are provided. An internal, rechargeable battery allows for operation for a

nominal 2.5 hours in the event of aircraft power loss and 30 minutes operation under all temperature conditions.

See *UAV-1004233-001, AV-30-E, Pilot's Guide* for additional details.

4.2 System Functions

Primary Functions

- Primary Attitude (AI Mode)
- Primary Slip (AI Mode)
- Primary Direction of Flight indication (DG Mode)
- Primary Navigation Information (with optional AV-HSI)

Supplemental Functions

- Indicated Airspeed
- Altitude
- Rate of Turn
- V-Speeds
- Angle of Attack
- Vertical Trend
- Vertical Speed
- Set Altitude
- Heading
- Bus Voltage
- G Load
- Outside Air Temperature
- True Airspeed
- Density Altitude
- GPS Navigator/Waypoint Data
- GPS Navigator Nav Data
- GPS Navigator Route Line
- Heading Bug

- Transponder Control
- Traffic Display (with optional AV-Link)

Audio and Visual Alerting Functions

- AoA Alerting
- G Limit Alerting
- Excessive Roll Alerting
- Attitude Miscompare (with optional AV-HSI)
- Set Altitude Alerting (visual only)
- Over/Under Voltage (visual only)
- Carbon Monoxide (with optional AV-Link and Sentry)

Miscellaneous Functions

- Internal Battery Operation
- Auto/Manual Brightness

Electrical Attributes	
Input Voltage Nominal	+10 to +32 VDC
Input Voltage Max	+60 VDC
Input Power Nominal	6 Watts (0.5 Amps @ 12VDC)
Input Power Max	12 Watts (1.0 Amps @ 12VDC)
Required Circuit Breaker	2 Amp
Physical Attributes	
Mounting Configuration	3-1/8" Round Instrument Hole
Electrical Connector	15 Pin Male D-Sub
Pneumatic Connectors	1/4" OD Quick Connect
Mounting	(4X) #6-32 Machine Screws
Case Material	Billet Aluminum
With Standard Lithium-Ion Battery Pack UAV-1004035-001 or UAV-1004035-002	
Dimensions w/o Connector	3.38" x 3.38" x 2.49"

Weight	0.56 Lbs.
Operation on Battery	1 Hr. Typ. @ 20°C / 30 Min Minimum @ -20C
With Extended NiMH Battery Pack UAV-1004035-003	
Dimensions w/o Connector	3.38" x 3.38" x 3.49"
Weight	0.90 Lbs.
Operation on Battery	2.5 Hr. Typ. @ 20°C / 30 Min Minimum @ -20C
Environmental	
Ground Survival Low	-55°C
Operating Low	-20°C
Ground Survival High	+85°C
Operating High	+55°C
Altitude	25,000 Feet (maximum)
Optical Characteristics	
Diagonal Size	3" Circular
Contrast Ratio (Typical)	500
Brightness (Typical)	1000 cd/m ²
Viewing Angle Left/Right	60°
Viewing Angle Up	45°
Viewing Angle Down	10°

Table 1 – System Specifications

5 Design Standards

This installation manual provides mechanical and electrical information necessary to install the AV-30. The content of this manual assumes use by competent and qualified personnel using standard maintenance procedures in accordance with Title 14 of the Code of Federal Regulation (CFR) and other related accepted procedures.

CAUTION

The installer must ensure that all installation limitations as defined in this document are observed.

The internal battery capacity has been tested and verified to provide 30 minutes of operational capacity (with reserve), and meets the requirements defined in CFR 23.1311(a)(5) and 23.1353(h), allowing independent operation from the primary electrical power system.

NOTICE

For aircraft capable of acrobatic flight, the AoA indication may become unreliable for operation in inverted flight and maneuvers exceeding ± 8 G.

For panels with more than 15 degrees of panel tilt, the AoA indication may not indicate correctly.

5.1 Applicable Performance Standards

The AV-30 was designed to and satisfied the applicable performance requirements defined in the following design standards:

MOPS	Title	Category
SAE AS8019	Airspeed Instruments	Type B
SAE AS392C	Altimeter, Pressure Actuated, Sensitive Type	Type I
SAE AS8005A	Minimum Performance Standard Temperature Instruments	Class IIIc
SAE AS8034	Minimum Performance Standard for Airborne Multipurpose Electronic Displays	N/A
RTCA DO-334	Minimum Operational Performance Standards (MOPS) for Strapdown Attitude and Heading Reference Systems (AHRS)	A5 H9 T7
SAE AS8013A	Minimum Performance Standard for Direction instrument, Magnetic (Gyroscopically Stabilized)	N/A
ASTM F3011-13	Standard Specification for Performance of Angle of Attack System	N/A
RTCA DO-347	Certification Test Guidance for Small and Medium Sized Rechargeable Lithium Batteries and Battery Systems	Medium Size
RTCA DO-293A	Minimum Operational Performance Standards (MOPS) for Nickel Cadmium, Nickel Metal-Hydride, and Lead-Acid Batteries	N/A
SAE AS6296	Electronic Flight Instrument System (EFIS) Displays	N/A

Table 2 – Applicable Performance Standards

6 Installation Limitations

The following technical limitations should be considered with installing the AV-30:

- Installation cannot replace an attitude indicator that is part of an autopilot system.
- Installation cannot replace a flight director that is part of an autopilot system.
- Installation cannot replace a turn coordinator that is part of an autopilot system.
- An electrical load analysis should be performed in association with the installation.
- A magnetic interference checkout should be performed in association with AV-Mag installation.

7 Installation Locations & Operating Modes

7.1 Installation Locations

The following figure shows a typical “six-pack” and one possible arrangement of instrument locations:

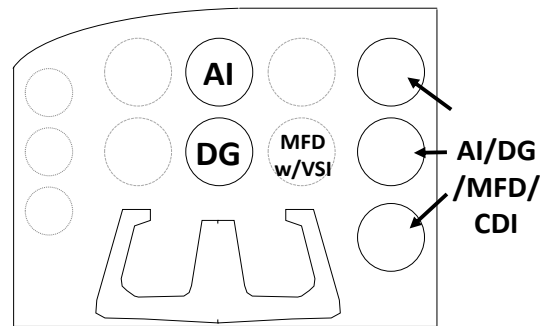

Figure 2 – Mechanical Gauge Replacement

Note that the physical arrangement in many aircraft varies from the configuration shown above. The AI/DG/MFD/CDI locations are examples of installation locations as a backup or supplemental instrument.

7.2 Operating Mode Configuration

The AV-30 operating mode is configured during installation and can be set as follows:

- Unit locked as a dedicated Attitude Indicator (AI Mode)
- Unit locked as a dedicated Direction Indicator (DG Mode); can be toggled between DG and MFD by the pilot.
- Unit unlocked; can be toggled between AI, DG, MFD, and CDI Modes by the pilot.

If the functionality is not locked, pressing and holding the rotary knob will toggle between AI, DG, MFD, and CDI Modes.

8 Functionality and Required Interfaces

8.1 Aircraft Systems Connections

All aircraft systems connections are provided on a single 15-Pin D-sub connector and two quick-connect pneumatic fittings. Various interfaces are optional as indicated in the following diagrams.

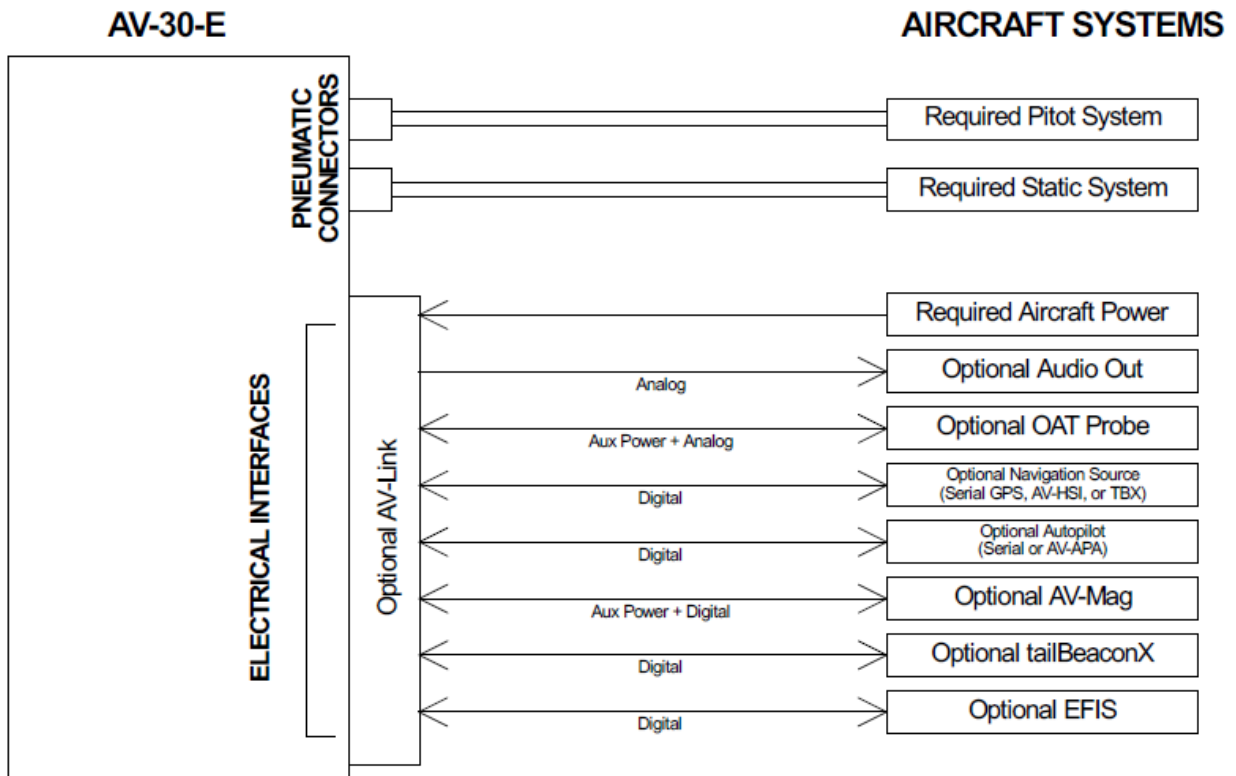

Figure 3 – AV-30 Aircraft Systems Interfaces – AI Mode

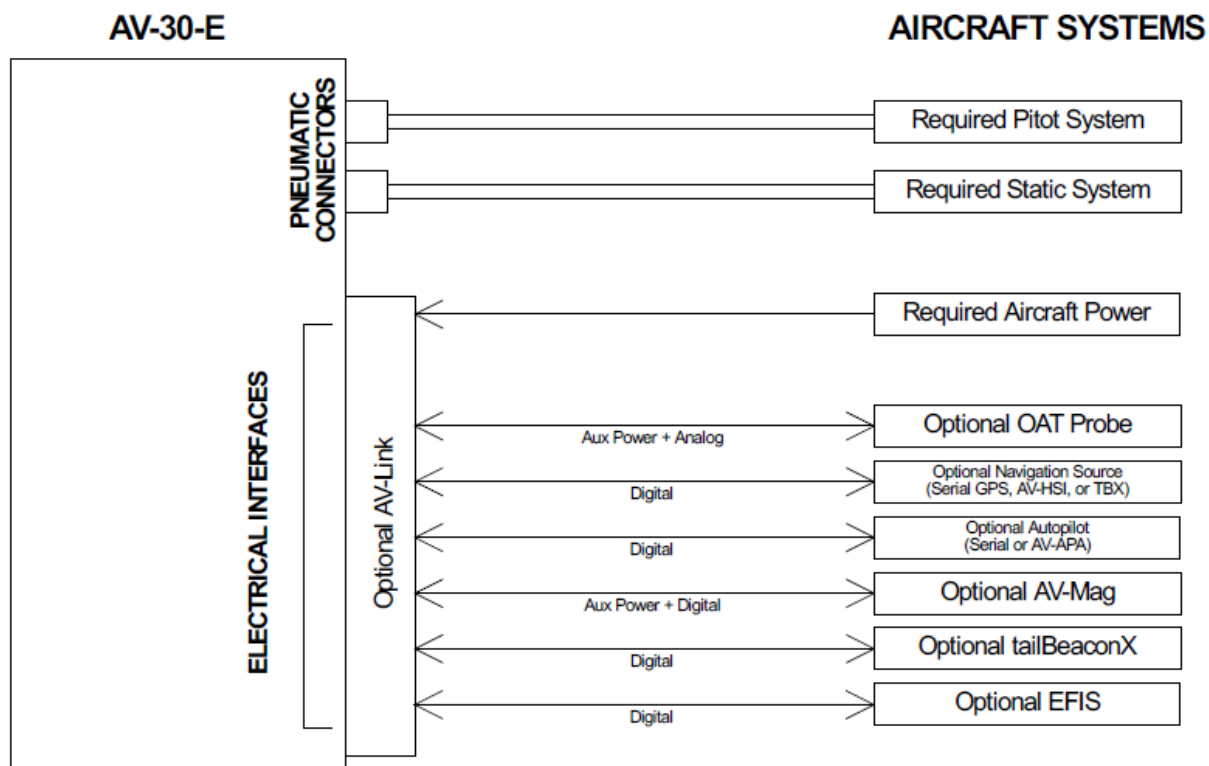

Figure 4 – AV-30 Aircraft Systems Interfaces – DG Mode

8.2 Feature Matrix

The following matrix shows primary and supplemental data and any required external interface.

Feature	AI Mode	DG Mode	Required Interface
Primary Attitude and Slip			
Primary Attitude	✓	✗	Pitot & Static
Primary Slip	✓	✗	Pitot & Static
Reversionary Attitude / Slip	✓	✓	Pitot & Static
Primary Direction of Flight Indication			
Direction Tape (DG / [GPS])	✓	✗	Pitot & static / [GPS Navigator]
Direction Rose (DG / [GPS])	✗	✓	Pitot & static / [GPS Navigator]
Direction Arc (DG / [GPS])	✗	✓	Pitot & static / [GPS Navigator]
Direction HSI (DG / [GPS])	✗	✓	Pitot & static / [GPS Navigator]
Primary Navigation Indication			
GPS Course and Glideslope	✓	✓	GPS Navigator
VOR/ILS Course and Glideslope	✓	✓	VOR/ILS Receiver
Supplemental Data Overlays – Pilot Configurable (Textual or Graphical)			
Indicated Airspeed (Textual)	✓	✗	Pitot & Static
V-Speeds (Graphical)	✓	✗	Pitot & Static
Baro Altitude (Textual)	✓	✓	Pitot & Static
Rate of Turn	✓	✗	Pitot & Static
Standard Rate Bank Angle	✓	✗	Pitot & Static, OAT Probe
Angle Of Attack (Graphical)	✓	✗	Pitot & Static
Vertical Trend (Graphical)	✓	✗	Pitot & Static
Vertical Speed (Textual)	✓	✓	Pitot & Static
Set Altitude (Textual)	✓	✓	None
Heading (Textual)	✓	✓	Pitot & Static
Bus Voltage (Textual)	✓	✓	None
G Load (Graphical)	✓	✗	None
G Load (Textual)	✓	✓	None
G Load Max Hold (Textual)	✓	✓	None
G Load Min Hold (Textual)	✓	✓	None
Outside Air Temp (Textual)	✓	✓	OAT Probe
True Airspeed (Textual)	✓	✓	Pitot & Static, OAT Probe
Density Altitude (Textual)	✓	✓	Pitot & Static, OAT Probe
Squawk (Textual)	✓	✓	BeaconX
Carbon Monoxide (Textual)	✓	✓	AV-Link + Sentry ADS-B Receiver
Navigation Mode (Textual)	✓	✓	AV-HSI
AP Mode (Textual)	✓	✓	Autopilot
Omni-Bearing Selector (Textual)	✓	✓	AV-HSI
GPS Navigation / Waypoint Data			
Textual Nav Data	✓	✓	GPS Navigator
Graphical Nav Data	✗	✓	GPS Navigator
Heading Bug			
Hdg Bug – Ref Only, no AP	✓	✓	None
Audio and Visual Alerting			

AoA Alerting	✓	✗	Pitot & Static
G Limit Alerting	✓	✗	None
Excessive Roll Alerting	✓	✗	None
Attitude Miscompare	✓	✗	AV-HSI
Carbon Monoxide	✓	✓	AV-Link + Sentry ADS-B Receiver
Misc.			
Internal Battery Operation	✓	✓	Pitot & Static
Auto / Manual Brightness	✓	✓	None
Transponder Control	✓	✓	Transponder Serial, Pitot & Static
Traffic display	✓	✓	AV-Link + ADS-B Receiver, Pitot & Static
External Magnetometer aid	✓	✓	AV-MAG, Pitot & Static

Table 3 – Feature Matrix

8.2.1 Power Input (Required)

Power input is required in all configurations. The power input is internally connected, and diode protected with the unit’s internal battery via a processor-controlled switch. This architecture allows the unit to continue operation if external power fluctuates or is completely lost. Input range is compatible with both 12V and 24V aircraft.

Each AV-30 must have a dedicated, properly labeled, pilot resettable circuit breaker as part of the installation. Power for the unit should be supplied from the main battery master relay. It is recommended to shield the power wire.

8.2.2 Pitot and Static Interfaces (Required)

Pitot and static connections are required for all installations, regardless of operating mode: AI, DG, MFD, or CDI.

Airspeed, altitude, attitude, derived angle of attack (AoA), True Airspeed (TAS), Density Altitude (DALT), DG heading, and traffic altitude all require pitot and static connections as they are based on either altitude or airspeed measured from those connections.

When installed as a DG, backup battery in flight, and DG heading aid require the pitot and static connections to be connected. Air data also aids the attitude algorithm, using a feature called speed assist.

8.2.3 Outside Air Temp Input (Optional)

The optional outside air temperature interface requires a dedicated external analog probe. This port connection is compatible with the Davtron P/N C307PS (not supplied).

This is a differential two-wire current source based on the Analog Devices AD590KH component and supplies a current that corresponds to the ambient temperature.

CAUTION

If two displays are connected to the same probe, the current will be split between the two and incorrect readings will be shown by both.

The sensor reading must be trimmed during the installation process to compensate for probe-to-probe variations.

The OAT probe is automatically detected by the system, and when detected, allows temperature related parameters to be selected for display by the pilot.

If the OAT probe is not detected, display of these parameters will automatically be inhibited.

8.2.4 Audio Output (Optional)

The optional audio panel connection is a low-voltage analog output that is designed to connect directly to an audio panel (typically a non-switched or unswitched audio input). High power outputs capable of directly driving a cockpit speaker are not provided.

Audio shields must be grounded only at the audio panel to avoid ground loops. Contact the audio panel manufacturer for further instructions.

When installed as a DG, no audio alerting is supported and this output should remain disconnected.

In non-metallic, IFR capable aircraft, the audio output should remain disconnected due to lightning strike limitations.

8.2.5 Navigation Interface (Optional)

The Navigation Interface is an optional RS-232 serial interface that can be connected to one of the following:

- “Aviation” output provided by most panel mounted GPS units
- NMEA output provided by most handheld GPS units
- AV-HSI (Horizontal Situation Indicator) that can be connected to the following:
 - One GPS Source (either ARINC 429 or NMEA)
 - One VOR/ILS Source (either ARINC 429 or Apollo SL30 protocol)
- BeaconX transponder GPS input

This interface receives text/binary output from a navigator that contains situational awareness information such as ground speed, track, distance to destination, cross track, etc.

Aviation, NMEA, and BeaconX GPS data does not provide IFR compliant lateral or vertical guidance, therefore all deviation related data presented in this configuration is for VFR operations only.

The AV-HSI provides IFR compliant lateral and vertical guidance when connected to a GPS Navigator and/or VOR/ILS receiver.

The AV-30 does not alter the data obtained from the GPS navigator and simply displays the received data in a textual or graphical format as configured by the pilot. The AV-30 will convert ground speed units to match IAS units for textual display.

NOTICE

Aviation and NMEA GPS may be connected in parallel between multiple AV-30 units and is supported in both AI and DG modes.

The supported protocols are contained in Section 14 - Serial Interface Specification.

GPS Receiver	GPS Track	VFR Guidance	IFR Guidance	MFD Traffic Display
uAvionix BeaconX	✓	✗	✗	✗
Aviation 4800	✓	✓	✗	✗
Aviation 9600	✓	✓	✗	✗
NMEA 4800	✓	✓	✗	✗
NMEA 4800	✓	✓	✗	✗
AV-HSI + ARINC 429 GPS	✓	✓	✓	✗
uAvionix Sentry + AV-Link	✗	✗	✗	✓
GDL90 ADS-B Receiver + AV-Link	✗	✗	✗	✓

Table 4 – GPS Functions by receiver type

Table 4 depicts the GPS functions performed by each receiver type. BeaconX transponders provide GPS track but do not have a waypoint database to provide navigation guidance. GPS data from an ADS-B receiver is used to drive the MFD Traffic display but is not used in other AV-30 modes.

NOTICE

The AV-HSI is not powered by the AV-30 internal battery. Navigation information will be unavailable during a power loss.

8.2.6 Internal Magnetometer (Optional)

The internal magnetometer, when available, is detected in software version 2.1.1 or later. It can be enabled or disabled by configuration. Application of magnetometer data requires calibration before use. The internal magnetometer calibration procedure is in §12.2.3 In-Flight Internal Magnetometer Calibration.

8.2.7 AV-Mag External Magnetometer (Optional)

The AV-Mag external magnetometer is supported in software version 2.3.0 or later. It is enabled with manual configuration in the installation menu. The installation of the AV-Mag magnetometer is sensitive to orientation and tilt so the installation instructions and measurements must be followed carefully. The magnetometer requires calibration before use. The AV-Mag receives power from the AV-30 and will run off the AV-30 backup battery in case of power loss. The AV-Mag transmits data to the AV-30 via an RS-232 serial interface.

NOTICE

The AV-Mag serial interface may be connected in parallel to multiple AV-30 units.

8.2.8 Transponder Control (Optional)

The AV-30 has the option of being the control interface for select uAvionix transponders (including the BeaconX family). This provides pressure altitude, mode, squawk code and IDENT information to the transponder, and displays status and annunciations from the

transponder. See § 10.2 for more information on the installation of the tailBeaconX.

NOTICE

The transponder is not powered by the AV-30 internal battery. Transponder operations will be unavailable during a power loss.

8.2.9 AV-Link Interface (Optional)

The AV-30 has the option of being a traffic display using AV-Link as an integrated Wi-Fi bridge that allows for communication between AV-30 and Wi-Fi capable ADS-B receivers. The AV-30 will display a separate MFD page with traffic when appropriate configured and connected to a supported receiver.

NOTICE

The AV-Link accessory is not powered by the AV-30 internal battery. Wi-Fi traffic data provided to the MFD mode will be unavailable during a power loss.

8.2.10 Autopilot Interfaces (Optional)

The AV-30 has options to control select analog and digital autopilots. Analog autopilots are controlled through the optional AV-APA accessory. Digital autopilots can be controlled directly or through the AV-HSI, without requiring the AV-APA.

NOTICE

The AV-APA is not powered by the AV-30 internal battery. Analog autopilot operations will be unavailable during a power loss.

8.3 Internal Battery Operation

8.3.1 General

The internal battery consists of a rechargeable battery system with automatic recharge, self-test, and power switching capability.

AV-30-E part numbers UAV-1004035-001 and UAV-1004035-002 include a standard Li-Ion battery pack that will provide approximately 1 hour of operation at standard temperatures and 30 minutes (minimum) of operational capacity over the operational temperature range.

AV-30-E part number UAV-1004035-003 includes an extended NiMH battery pack that will provide approximately 2.5 hours of operation at standard temperatures and 30 minutes (minimum) of operational capacity over the operational temperature range.

When power is lost to the AV-30, the following will occur:

1. While AV-30 is aligning, the unit will continue in battery mode if power is lost. Once aligned it will shut down.
2. If any button is pressed after power is lost, the AV-30 will stay in battery mode.
3. If the AV-30 senses airspeed or GPS groundspeed, it will stay in battery mode. Pitot and static ports must be properly connected.

If the AV-30 needs to be shut down after removing power, push and hold the left and right buttons simultaneously until the unit shuts down.

See the *Pilots Guide UAV-1004233-001 §10 Internal Battery Operation* for additional operational information.

9 Equipment Installation

9.1 Overview

Installation consists of the following steps:

- Remove / relocate any legacy instrumentation
- Add or locate an appropriate power source / breaker
- Wire power and system interfaces as needed
- Mount the unit to the instrument panel with supplied screws
- Apply power and perform setup
- Connect pitot and static. Perform leak check after installation
- (Optional) Install the AV-Mag external magnetometer and perform calibration

9.2 Supplied Components

This installation manual is applicable to the following components and part numbers:

Component	Part Number	Description
AV-30-E Unit	UAV-1004035-001	AV-30-E Unit without Internal Magnetometer
	UAV-1004035-002	AV-30-E Unit with Internal Magnetometer
	UAV-1004035-003	AV-30-E Unit with Extended NiMH battery
AV-30-E Installation Kit	UAV-1004091-001	Installation Kit
AV-30-E Operating Software	UAV-1004037-012	AV-30-E Operating Software v3.0.0
(Optional) AV-Link-E	UAV-1004413-001	AV-Link Wi-Fi Bridge
(Optional) AV-Mag-E	UAV-1006321-001	AV-Mag External Magnetometer

(Optional) AV-APA	UAV-1006839-001	AV-APA Analog Port Adapter
(Optional) AV-HSI	UAV-1007412-001	AV-HSI ARINC 429 Adapter



Table 5 – Supplied Components

The AV-30 Installation Kit includes the following:

- 6-32 mounting screws
- 15-pin harness housing and associated pins
- Braided ground cable
- Ring terminals

NOTICE

The installation kit has been updated to use machined pins instead of the original stamped pins.

Original Stamped Pins	Updated Machined Pins
 <p>A close-up photograph of an original stamped pin. It is a cylindrical metal component with a complex, multi-faceted top section that appears to be a crimp or a specific electrical contact. The metal has a yellowish-gold or brass-like finish.</p>	 <p>A close-up photograph of an updated machined pin. It is a long, smooth, cylindrical metal pin with a silver or stainless steel finish. The top end is slightly tapered and has a small blue band or marking near the tip.</p>

If your kit includes machined pins, a Daniels AFM8 crimp tool using a K13-1 positioner or equivalent M22520/2-01 tool should be used. If your

installation kit includes the original stamped pins, a NorComp 180-701-170-000 hand crimper or equivalent should be used.

9.3 Non-Supplied Components

The following components are not included and may be required for installation:

Component	Description
Pitot / Static Tubing	Length as required
Pitot Static T's	Quantity as required
Circuit Breakers (2A)	One required for each instrument
OAT Probe (optional)	Davtron P/N C307PS
Power and Interconnect Wire	22 or 24 AWG MIL-C-27500 shielded wire

Table 6 – Non-Supplied Components

9.4 Installation Records

The date of installation should be recorded in the aircraft's logbook.

Entry should include instrument(s) being replaced.

Entry should also include a description of any optional connections made.

Entry should include AV-Mag installation location, orientation, and attitude angles.

9.5 Mechanical Drawing

AV-30-E part numbers UAV-1004035-001 and UAV-1004035-002 include a standard depth Li-Ion battery pack, with mechanical dimensions shown below. The center drawing depicts an AV-30 with an optional AV-Link attached.

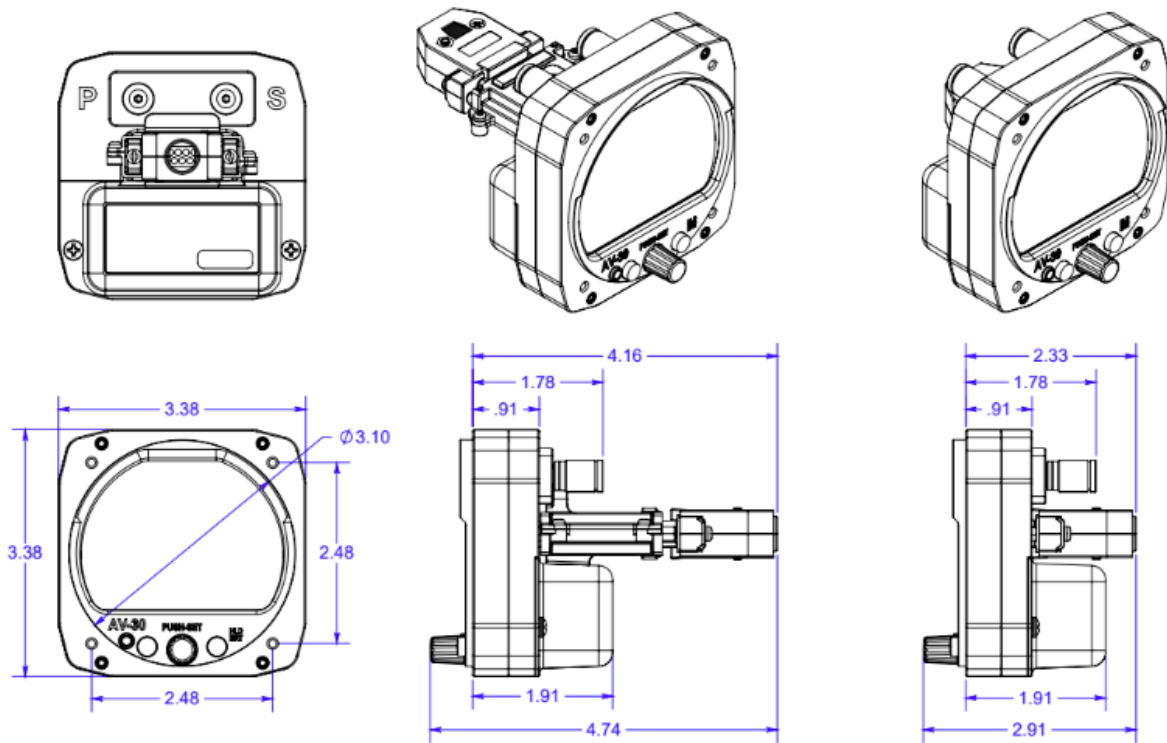

Figure 5 – Mechanical Drawing with Standard Li-Ion Battery

AV-30-E part number UAV-1004035-003 includes an extended NiMH battery pack, with mechanical dimensions as shown below. The center drawing depicts an AV-30 with an optional AV-Link attached.

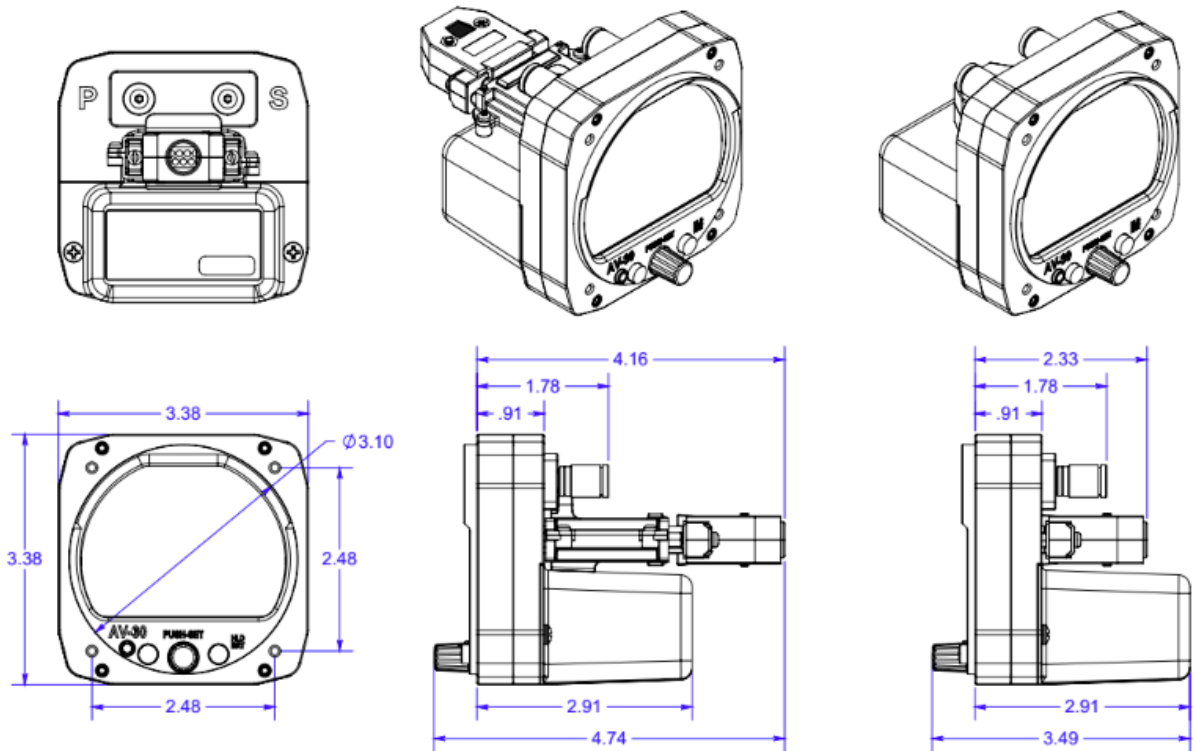

Figure 6 – Mechanical Drawing with Extended NiMH Battery

9.6 Mounting the AV-30

The AV-30 is fastened to the instrument panel with four Stainless Steel 6-32 screws. The unit mounts from the rear of the instrument panel, with the screws being inserted from the front of the panel.

CAUTION

The four 6-32 Mounting screws must observe depth limits given the internal component design. The mounting holes are “blind” and there are sensitive components located under the screw. Using screws that are too long can break the housing and damage the components inside.

NOTICE

Torque screws to 6 (+/-1) inch-lbs. Do not over-torque or damage may occur.

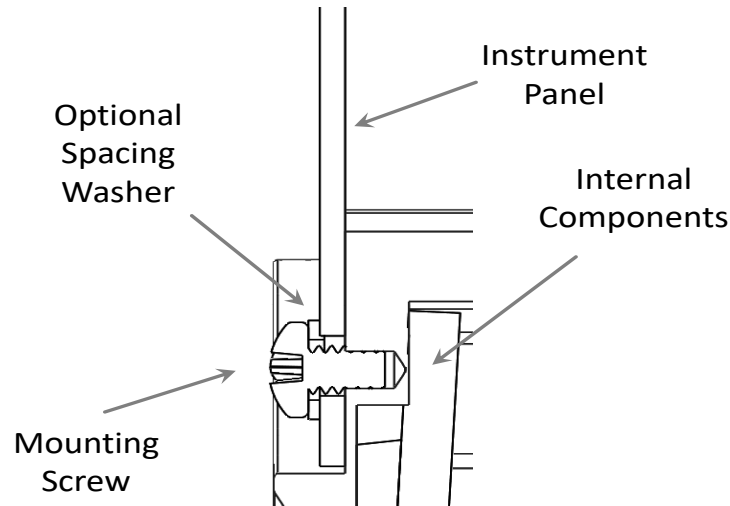

Figure 7 – Mounting Screw Depth Limits

Caution must be observed when mounting the AV-30. If too long a screw is used, damage to the unit can occur, and the unit may not be securely fastened to the panel. The installation kit contains multiple length screws to assist in compensating for different instrument panel thicknesses. Due to the short thread engagement, if you will be providing your own screws, be sure to choose stainless steel instead of brass as typically used for instrument mounting.

The objective when mounting the AV-30 is to achieve the greatest screw engagement without exceeding the limits of the housing, causing damage. Using screws that are too short could lead to stripped mounting holes. Always use caution when tightening the mounting screws, if the screw feels like it is bottoming out, STOP, and correct the screw thread

engagement. Correct screw thread engagement may be determined and adjusted in the following ways.

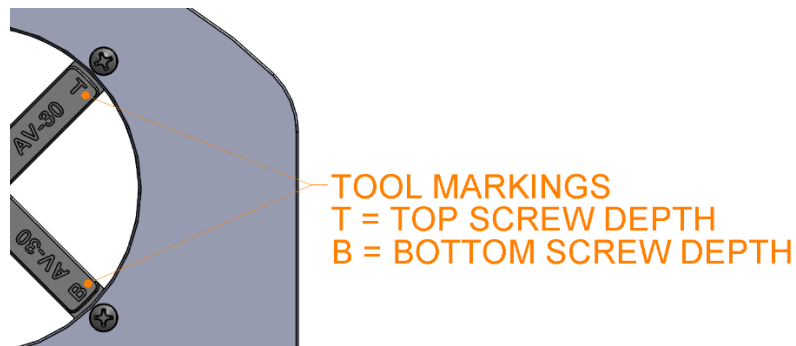

Figure 8 – Install tool used for Top and Bottom Screw Engagement Check

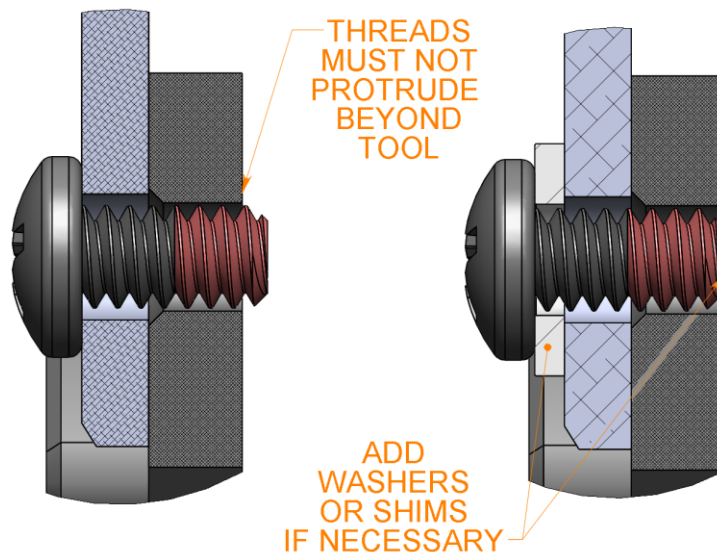

Figure 9 – Proper Screw Engagement Adjustment

1. Installation Tool: If the installation kit contains a screw depth gauge, perform the following steps to determine the correct screw lengths:
 - a. Hold the depth gauge behind the panel so the “T” hole on the depth gauge aligns with the top left screw hole in the panel. Place a mounting screw through the panel and feel the back

surface of the tool where the screw should be. The screw can be flush with the tool surface or up to 0.5mm (0.020in) below the surface. If the screw protrudes past the depth gauge the screw is too long. Select a shorter screw or use standard hardware shims/washers installed under the head of the screw (not provided) to adjust the screw depth.

- b. Perform step a. again, measuring the top right screw hole.
- c. Hold the depth gauge behind the bottom left screw hole, aligning the “B” hole on the depth gauge with the panel screw hole. Again, if the screw protrudes past the depth gauge the screw is too long. Select a shorter screw or use standard hardware shims/washers installed under the head of the screw (not provided) to adjust the screw depth.
- d. Perform step c. again, measuring the bottom right screw hole. Note that the lower two holes accommodate slightly longer screws than the upper two holes, but the same process should be used to achieve the greatest thread engagement.

2. Measurement: The permissible thread engagement in the top mounting holes is 3.2mm. The permissible thread engagement in the bottom mounting holes is 4.2mm.

	Minimum hole engagement	Maximum hole engagement
Top holes	2.7 mm	3.2 mm
Bottom holes	3.7 mm	4.2 mm

You can use digital calipers or other accurate means to measure the length of the screw (every screw is manufactured different), then measure your panel thickness. Subtract the panel thickness from your

screw length. If this length is greater than 3.2 or 4.2 for each respective Top or Bottom location, you will need to add washers when installing the screws. Repeat this measurement of exposed threads with shims/washers on the screws until you are under and within 0.5mm (0.020in) of the listed depths.

- a. Screw thread length measured = 6.35mm (0.250in screw)
- b. Panel thickness measured = 2.29mm (0.090in panel)
- c. Thread engagement = $6.35 - 2.29 = 4.06\text{mm}$
 - i. This screw may be used in the Bottom Mounting holes since $4.06\text{mm} < 4.2\text{mm}$, but NOT in the top mounting holes as it is too long.
- d. Screw thread length measured = 4.76mm (0.1875in screw)
- e. Panel thickness measured = 2.29mm (0.090in panel)
- f. Thread engagement = $4.76 - 2.29 = 2.47\text{mm}$
 - i. This screw may NOT be used in the Top or Bottom Mounting holes since the length is too short. You will need to use a longer screw or a longer screw with shims/washers.

NOTICE

Installing an AV-30 into panel cutouts where one of the 4 mounting hole locations has been enlarged for prior Baro Setting knob, DG Adjustment knob, or Heading Bug knob clearance will increase the mounting difficulty. Use extreme caution when using reducing washers while adjusting screw engagement in these locations. The reducing washers will flex more than traditional washers causing the screws to have deeper engagement. You can still use the installation tool in this case by turning the tool over and aligning the Bottom depth gauge hole with the

mounting hole while ‘bridging’ the tool across the opening to ensure it is flat on the back of the panel as shown below. Insert your reducing washer and screw and repeat the process from 1c above. Use caution when tightening the screw.

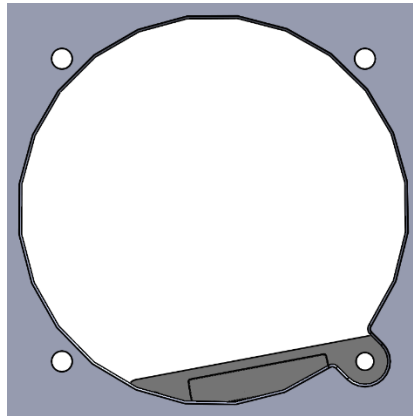

Figure 10 – Bridging using back side of tool when working with enlarged holes and reducing washers.

9.7 Wiring Diagrams

The AV-30 interfaces with several external devices and therefore wiring will vary depending on the installation and if the unit is installed as an AI, DG, MFD, or CDI. Figure 11 shows the required connections on all AV-30. Figure 12 shows the wiring of optional analog accessories and measurement devices. Figure 13 shows the wiring of optional digital accessories. Installation is likely to be an aggregate of these three figures.

Use 22 or 24 AWG MIL-C-27500 or equivalent shielded wire unless another is specified in the installation drawings. AC 43.13-1B should be used for additional guidance where needed.

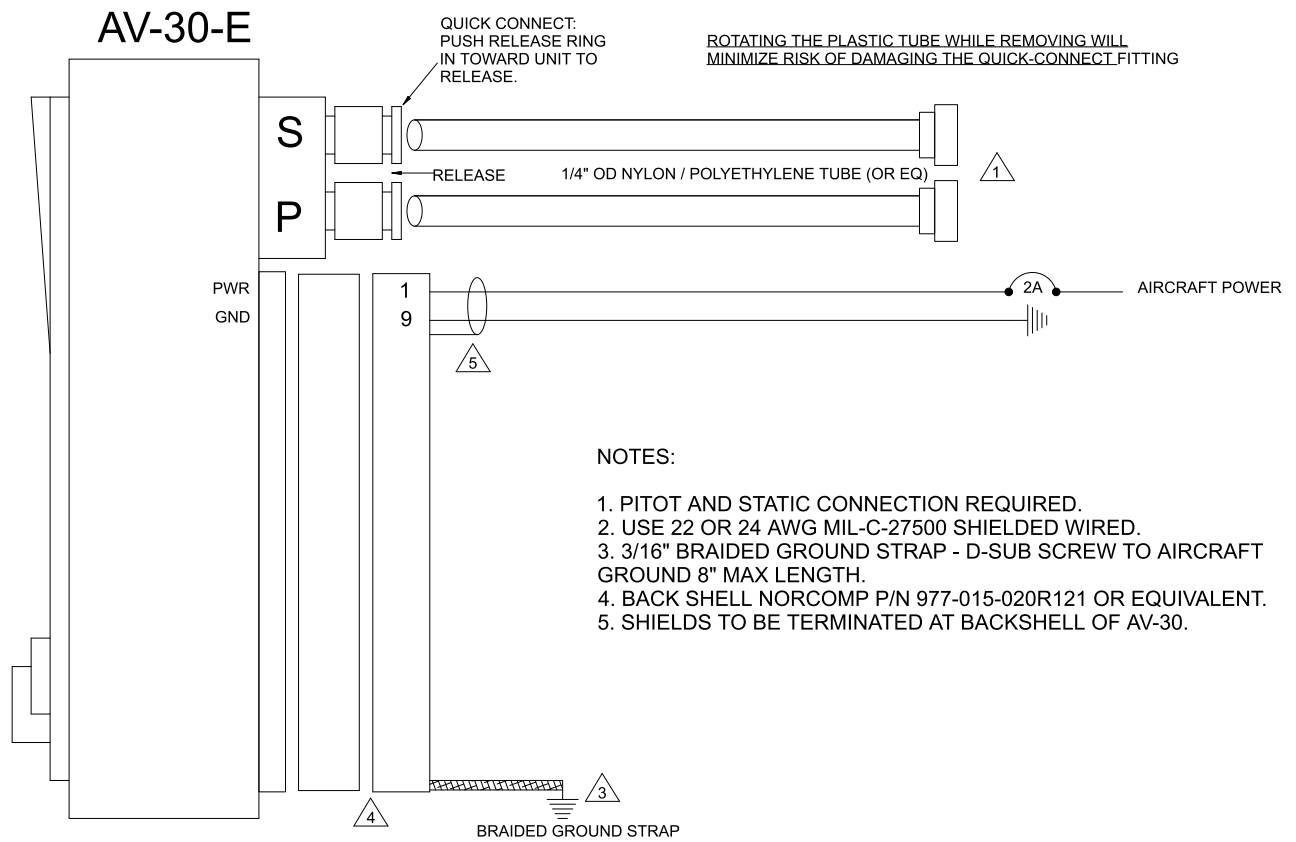
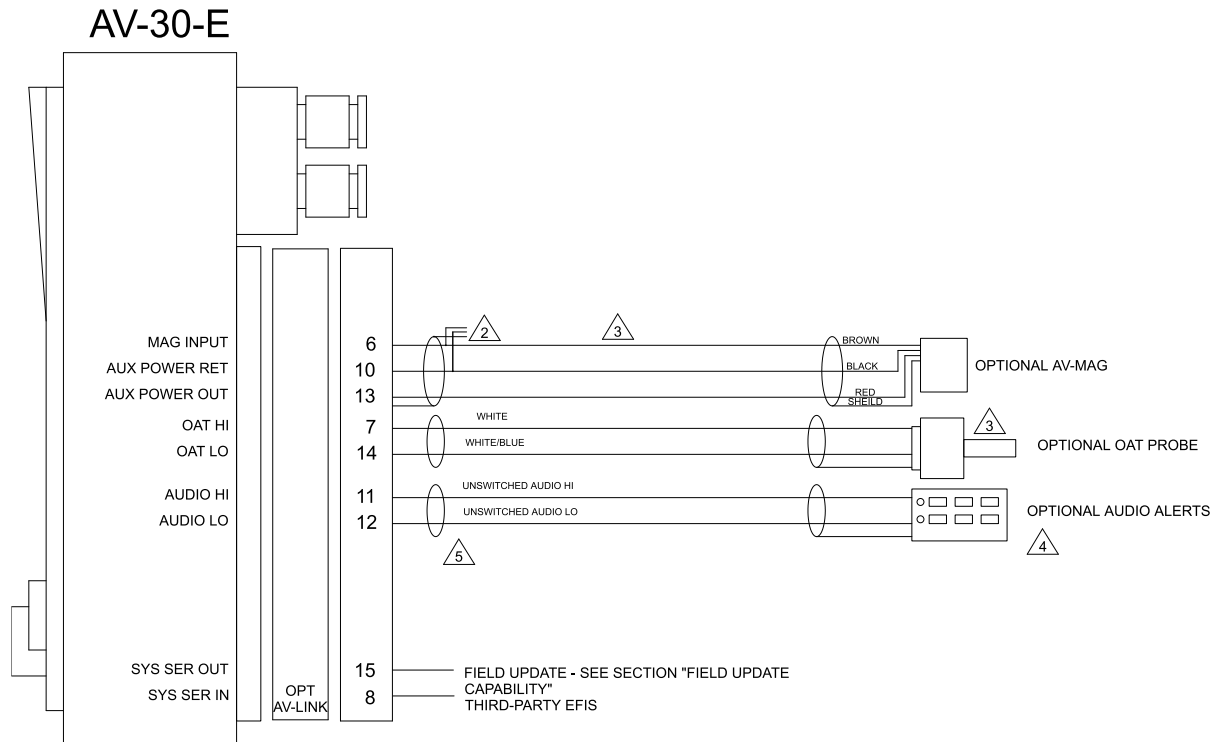

Figure 11 – Wiring Diagram – Required Connections



NOTES:

1. USE 22 OR 24 AWG MIL-C-27500 SHIELDED WIRED.
2. AV-MAG MAY BE PARALLELED TO ADDITIONAL AV-30. FOR PARALLEL OPERATION CONNECT PINS 6, 10, AND SHIELD TO ADDITIONAL AV-30. DO NOT CONNECT PIN 13 TO ADDITIONAL AV-30.
3. AV-MAG INCLUDES APPROXIMATELY 12" OF WIRE. EXTEND WITH M27500-24TG3T14, M27500-22TG3T14 OR EQUIVALENT.
3. FOR DALI, TAS, OAT, FUNCTIONALITY, PITOT, STATIC, AND OAT MUST ALL BE CONNECTED. OAT PROBE CAN NOT BE PARALLELED.
4. AUDIO ALERTS FOR FOR THE AI CONFIGURATION ONLY. DO NOT CONNECT IF INSTALLED AS DG.
5. DO NOT CONNECT WIRE SHIELD FOR AUDIO AT AV-30. CONNECT SHIELD ONLY AT AUDIO PANEL.
6. CONNECT AV-MAG SHIELD TO AV-30 BACK SHELL AND TO AV-MAG.

Figure 12 – Wiring Diagram – Optional Connections 1 of 2

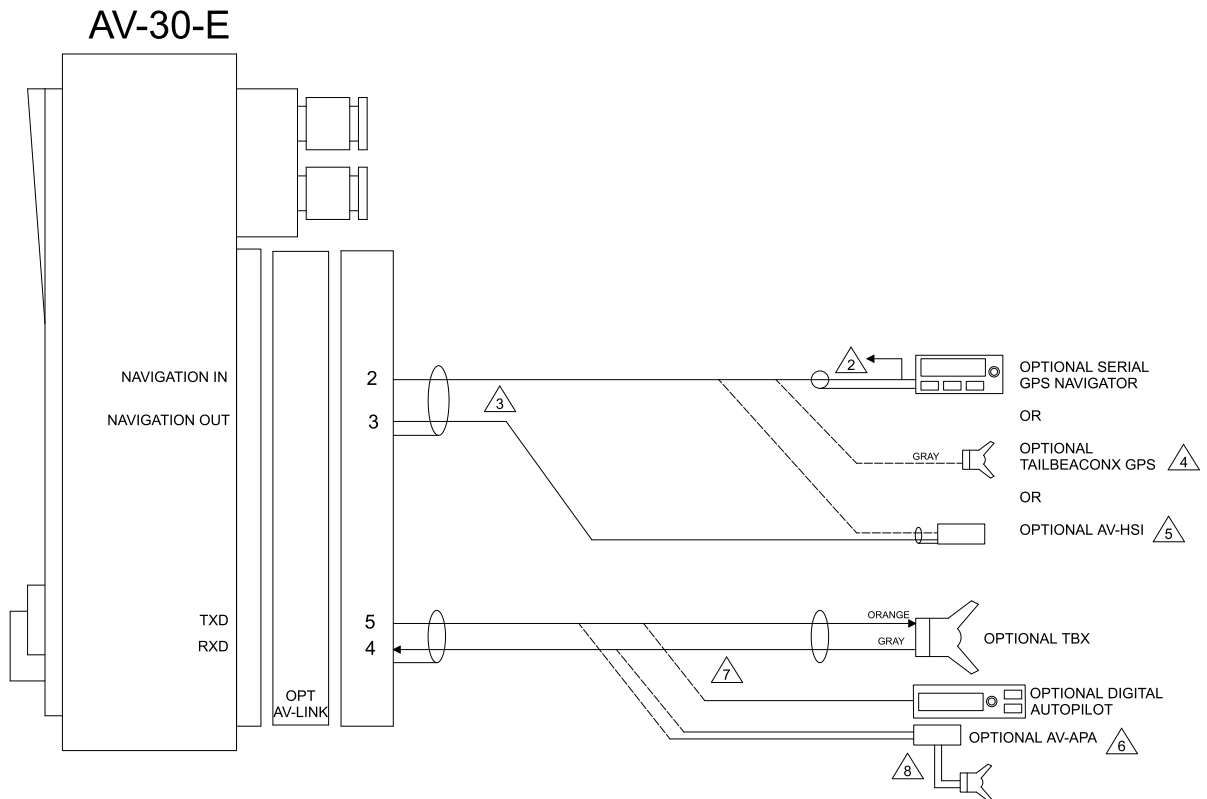

NOTES:

1. USE 22 OR 24 AWG MIL-C-27500 SHIELDED WIRED.
2. SERIAL GPS NAVIGATOR MAY BE PARALLELED TO ADDITIONAL AV-30.
3. ONLY ONE DEVICE MAY BE CONNECTED TO PINS 2 AND 3. CHOOSE BETWEEN SERIAL NAVIGATOR, TAILBEACONX AS GPS, AND AV-HSI.
4. AV-30 MAY SERVE AS A CONTROL HEAD FOR A TAILBEACONX OR MAY USE THE TAILBEACONX AS A GPS SOURCE. DO NOT CONNECT AS BOTH. SEE TRANSPONDER INSTALLATION INSTRUCTIONS FOR ADDITIONAL DETAILS.
5. SEE AV-HSI INSTLLATION SECTION FOR ADDITIONAL DETEAILS.
6. SEE AV-APA INSTALLATION SECTION FOR ADDITIONAL DETAILS.
7. ONLY ONE DEVICE CAN BE CONNECTED TO PINS 4 AND 5. CHOOSE BETWEEN AV-APA, TAILBEACONX, OR DIGITAL AUTOPILOT.
8. A TAILBEACONX CAN BE DAISY-CHAINED THROUGH THE AV-APA. SEE AV-APA INSTALLATION SECTION FOR DETAILS.

Figure 13 – Wiring Diagram – Optional Connections 2 of 2

9.8 Bonding Requirements

The following figures show the grounding requirements for the electrical connections. The two D-Sub screws are to be utilized for shield and ground strap connections.

The supplied ring terminal connectors are sized for these screws.

The ground braid strap is to be less than 8 inches in overall length and at least 3/16 width, Alpha Wire part number 1230 SV001 or equivalent.



Figure 14 – Ground Braid Strap – 8” or Less in Length

The exposed (non-shielded) portions of the interface cables AND the shield grounds are to remain less than 2.5 inches.

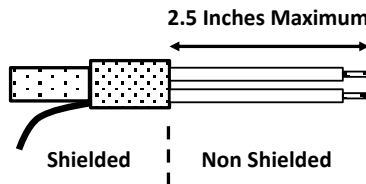

Figure 15 – Shielded Cable

CAUTION

The bond between the unit (measured at the D-sub screws) to the aircraft frame must be 2.5 milli-Ohms or less.

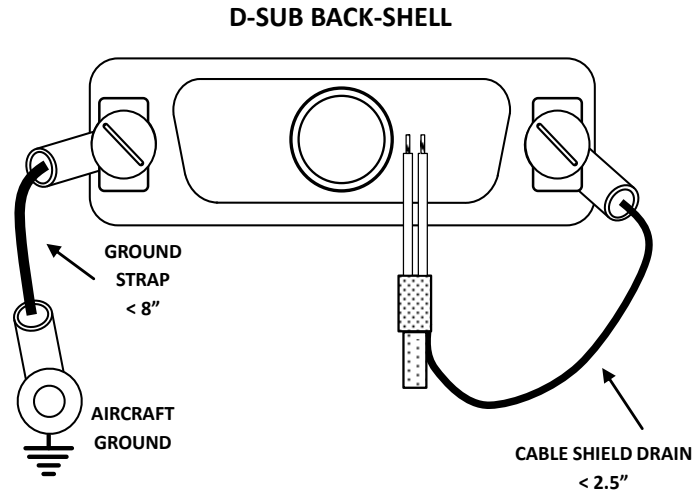

Figure 16 – Cable Shields and Ground Strap

9.9 Unit Pinout

Pin	Function	Type	Comment
1	Power	Power	+12 to +28 VDC
2	Navigation In	Input	GPS OR AV-HSI RS-232 Input
3	Navigation Out	Output	AV-HSI RS-232 Output
4	Serial 2	Input	Transponder OR AV-APA
5	Serial 2	Output	Transponder OR Autopilot RS-232 OR AV-APA
6	Serial 4	Input	AV-Mag Data
7	OAT Supply	Output	White Probe Wire
8	Serial 3	Input	Software Update Harness or Third Party EFIS
9	Ground	Power	Aircraft Ground
10	Aux Power Ret	Power	AV-Mag / Auxiliary Power return
11	Audio H	Output	Audio Alerts hi
12	Audio L	Output	Audio Panel lo
13	Aux Power Out	Power	AV-Mag / Auxiliary Power
14	OAT Return	Input	White / Blue Probe Wire
15	Serial 3	Output	Software Update Harness or Third Party EFIS

Table 7 – Connector Pinout

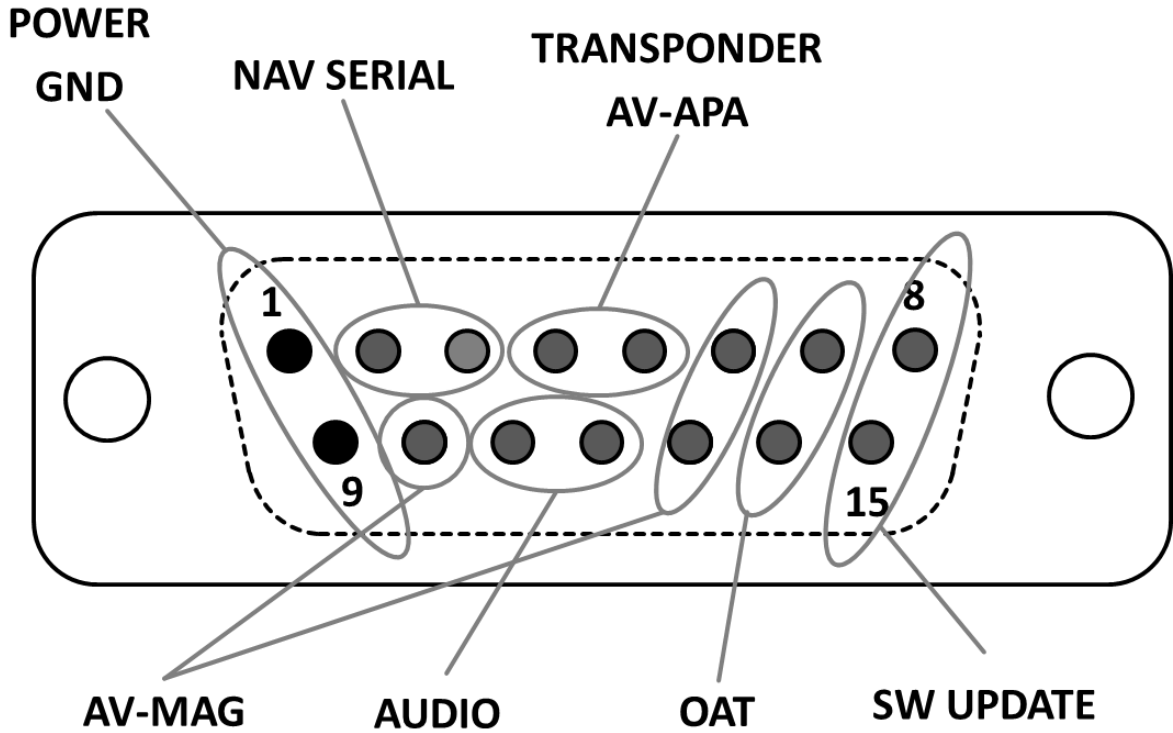

Figure 17 – Unit Connections – DB-15, Male (Rear Unit View)

10 Optional Equipment Installation

10.1 AV-Link

AV-Link (P/N UAV-1004413-001) is an integrated Wi-Fi bridge that allows for communication between AV-30 and Wi-Fi enabled devices. Software updates for AV-Link and AV-30 can be performed via a web page. Configuration settings and device status are accessible through the embedded web page. See § 10.1.15 for steps on updating firmware using the AV-Link.

10.1.1 System Function

AV-Link and AV-30, when paired with an ADS-B receiver, can display traffic information. This information is supplemental and for advisory use only. It cannot replace required equipment.

10.1.2 FCC ID

The AV-Link contains the following FCC ID: 2AC7Z-ESPWROOM02U.

10.1.3 AV-Link Specifications

The AV-Link specifications are as follows:

Characteristics	Specifications
Part Number	UAV-1004413-001
Width	52.06 mm
Height	25.91 mm
Depth	52.63 mm
Weight	1.1 oz (32.2 grams)
Operating temperature range	-45°C to +70°C
Maximum pressure altitude	35,000 ft
Input voltage range	9 to 30.3 VDC
14V current	0.02A idle 0.025A typical 0.05A maximum
28V current	0.01A idle 0.0125A typical 0.025A maximum

Table 8 – AV-Link Specifications

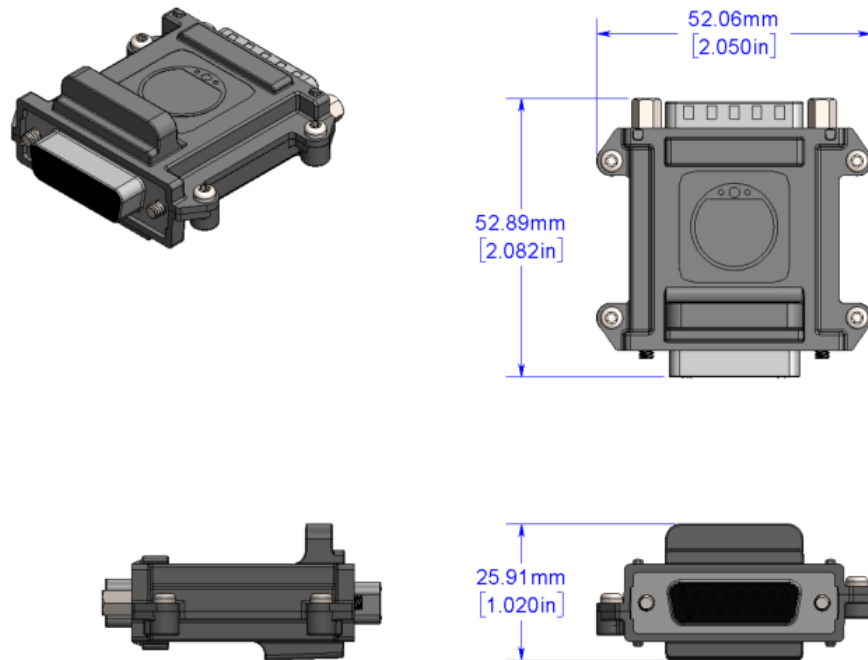

Figure 18 – AV-Link Mechanical Drawing

10.1.4 AV-Link Software

The software contained in the AV-Link device is identified by electronic marking. Software version information can be accessed via an embedded web page.

10.1.5 AV-Link Installation Materials and Tools

AV-Link installation requires access to these tools:

- Flat Screwdriver
- 3/16" Nut Driver

10.1.6 Additional Required Equipment

AV-Link is designed to interface with an existing AV-30 display.

10.1.7 Mounting

AV-Link is mounted in series between the AV-30 and the AV-30 backshell connector.

10.1.8 Removing AV-30 From Instrument Panel (Optional)

It may be necessary, because of space limitations, to remove the AV-30 unit for performing AV-Link installation. Using a Phillips screwdriver, remove the four [4] screws that attach the AV-30 to the aircraft instrument panel. Pull unit down to a workable position. Note that it may also be necessary to disconnect the Pitot and Static lines to bring it into reach. Ensure that the lines are properly labeled before disconnecting.

10.1.9 AV-30 Backshell Connector Removal

Using a flat screwdriver, loosen the two [2] screws that hold the backshell connector to the DB-15 connector on the back of the AV-30 until the backshell connector is free to detach from the AV-30. If present, leave the bonding/ground strap attached to the backshell connector.



Figure 19 – AV-Link Backshell Connector Removal

10.1.10 AV-Link Attachment

Do not attempt to remove the two [2] captive Jack Screws from the AV-Link housing. Attach AV-Link to the back of the AV-30 by inserting the unit into the DB-15 connector on the back of the AV-30.

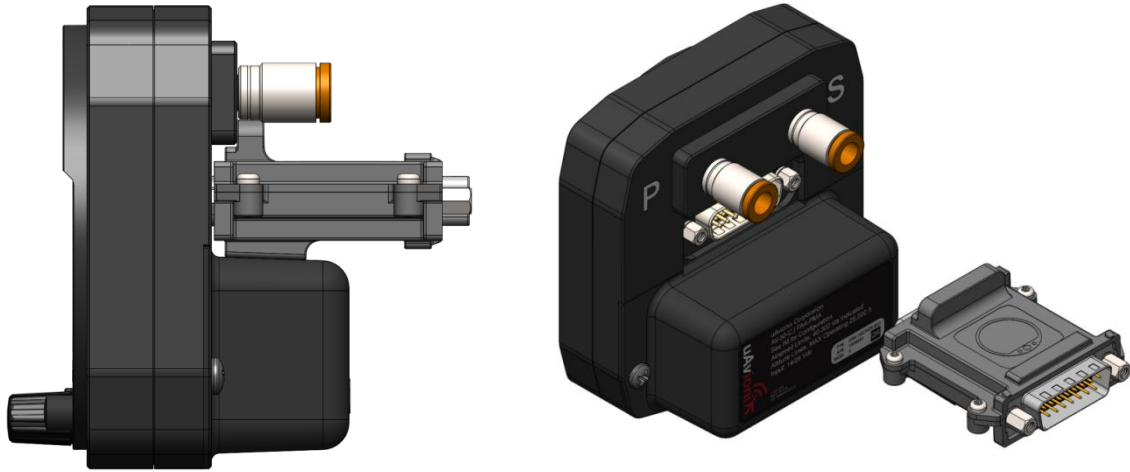

Figure 20 – AV-Link attachment

Do not push against the Jack Screws as they will stop against the screw bosses on the AV-30 connector preventing proper seating of AV-Link. Also, make sure to seat the AV-Link completely before tightening the Jack Screws.

Do not attempt to use the Jack Screws to pull AV-Link into the AV-30 connector. AV-Link should seat firmly into the AV-30 as shown in Figure 21.

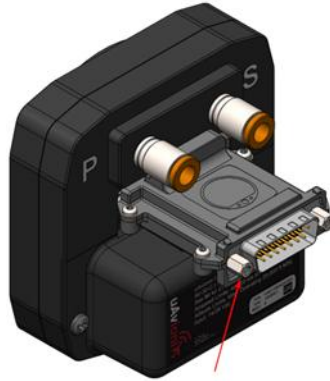

Figure 21 – AV-Link installed

Using a 3/16” nut driver, tighten the two [2] Jack Screws to 5 in-lbs. maximum. Do Not Overtighten!

Reattach the original AV-30 Backshell Connector. Using a flat screwdriver, tighten the two [2] screws to 5 in-lbs. maximum.

Do Not Overtighten!



Figure 22 – AV-Link attachment with backshell

10.1.11 AV-30 Reinstallation in Instrument Panel

If the AV-30 was removed from the aircraft instrument panel, reinstall the unit. If the original screws have been misplaced, please observe § 9.6 Mounting the AV-30.

10.1.12 AV-30 Configuration

In the AV-30 Installation menu, set SERIAL 3 to AV-LINK. See § 12 Installation Menu guidance on accessing the Installation Menu.



10.1.13 System Limitations

AV-Link is designed to supplement an AV-30. System limitations for AV-Link are determined by AV-30 limitations.

10.1.14 Connecting to the AV-Link via Wi-Fi

As shipped from the factory, the AV-Link will function in default mode and should not need customization. If it is necessary to change AV-Link settings or apply firmware updates, the AV-Link may be accessed through a web browser.

Windows, MacOS, iOS and other devices are supported using the built-in web browser on your computer. To connect to the AV-Link through your browser, configure your computer for the AV-Link Wi-Fi connection.

1. Power AV-Link by attaching the AV-Link to AV-30 to provide power.
2. Once the AV-Link is powered, on your computer, connect to the AV-Link Wi-Fi hotspot, which will have an "AV_XXXX" SSID, where XXXX is a combination of alpha-numeric characters.

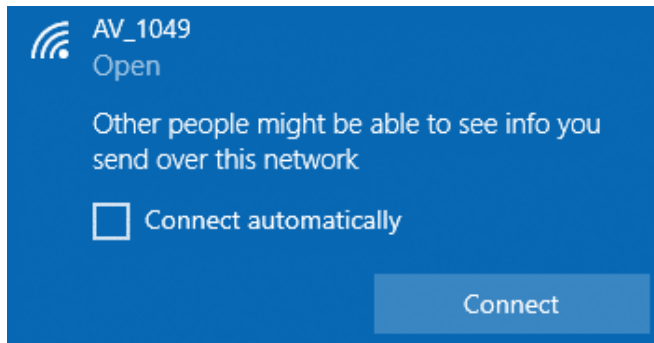

3. Once connected, use your web browser to navigate to 192.168.5.1 to view AV-Link settings.

10.1.15 Wi-Fi Firmware Update Page

Note: All settings changes should be performed while on the ground. Accessing the AV-Link web pages while in flight is not recommended and may disrupt normal operations of AV-30 and AV-Link.

The AV-Link firmware update page permits firmware updating of AV-Link. Refer to the most recent service bulletin for the latest firmware update instructions.

10.1.16 AV-Link Factory Reset

The AV-Link can be returned to factory settings from the AV-30 installation menu. For example, if the WiFi password was set but forgotten, the factory reset will delete the password. AV-Link software version 0.2.39 or later is required to support factory reset.

To execute factory reset, go to the AV-30 installation menu item named “RESET AVLINK”, select YES, then press and hold the right button until “COMPLETE” appears.

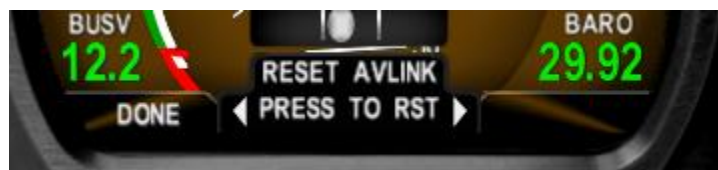



10.1.17 Optional AV-Link Connected to AV-HSI

Starting with AV-30 Software release 3.0.0, a single AV-Link can be connected directly to an AV-HSI. In this configuration, the single AV-Link provides the traffic and Sentry carbon monoxide alerts to every AV-30 connected to the AV-HSI. Additionally, the single AV-Link can be used to update the AV-HSI and any connected AV-30.

To use this configuration, attach the AV-Link directly to the AV-HSI and connect the AV-HSI's DB15 connector to the other side of the AV-Link.

Configure the AV-30 as follows:

1. In the AV-30 Installation Menu, navigate to AVHSI CFG and press the center knob to select.



2. Navigate to SERIAL 4.
3. If there is an AV-30 connected to pins 8 and 15 of the AV-HSI, set SERIAL 4 to AVL+AV30. Otherwise set to AV-LINK.



4. Connect a PC or tablet to the AV-LINK Wi-Fi connection following the steps in §10.1.14 Connecting to the AV-Link via Wi-Fi.
5. Select "Wi-Fi Settings" in the bottom left corner.

- In the AV-HSI Settings section, specify if the AV-Link is connected to an AV-HSI with or without an AV-30 connected to COM4 (Pins 8 and 15).

← → ↻ ⚠ Not secure http://192.168.5.1/settings

Wi-Fi Settings
 SSID: Broadcast
 Password:
 Power Level:

ADS-B Receiver Settings
 SSID: Auto Connect
 Password:
 Port:
 Status: Waiting

AV-HSI Settings
 Connected Devices:

- None
- AV-HSI without AV-30 on COM4**
- AV-HSI with AV-30 on COM4

- Click Save. Power cycle the AV-30, AV-HSI, and AV-Link

10.2 Transponder (tailBeaconX)

NOTICE

For complete installation guidance, see *tailBeaconX TSO Installation Manual, UAV-1004270-001* and *tailBeaconX STC Installation Manual UAV-1003599-001*.

For operation of tailBeaconX using the AV-30, see *AV-30-E Pilot's Guide, UAV-1004233-001*.

tailBeaconX is a complete Mode S Extended Squitter (ES) ADS-B OUT transponder, integrated with an internal SBAS/WAAS GPS and all necessary antennas into an LED rear position light. tailBeaconX is designed to meet the transponder and ADS-B requirements for operating in controlled airspace worldwide, while minimizing installation costs.

tailBeaconX can optionally provide GPS track and groundspeed information to the AV-30.

For parallel connection of a tailBeaconX to two AV-30s, connect and configure the AV-30s according to Figure 23. Note that the tailBeaconX will only output GPS data when controlled by an AV-30. As diagramed in Figure 23, the top AV-30 will only receive GPS data if the bottom AV-30 is powered on and configured properly.

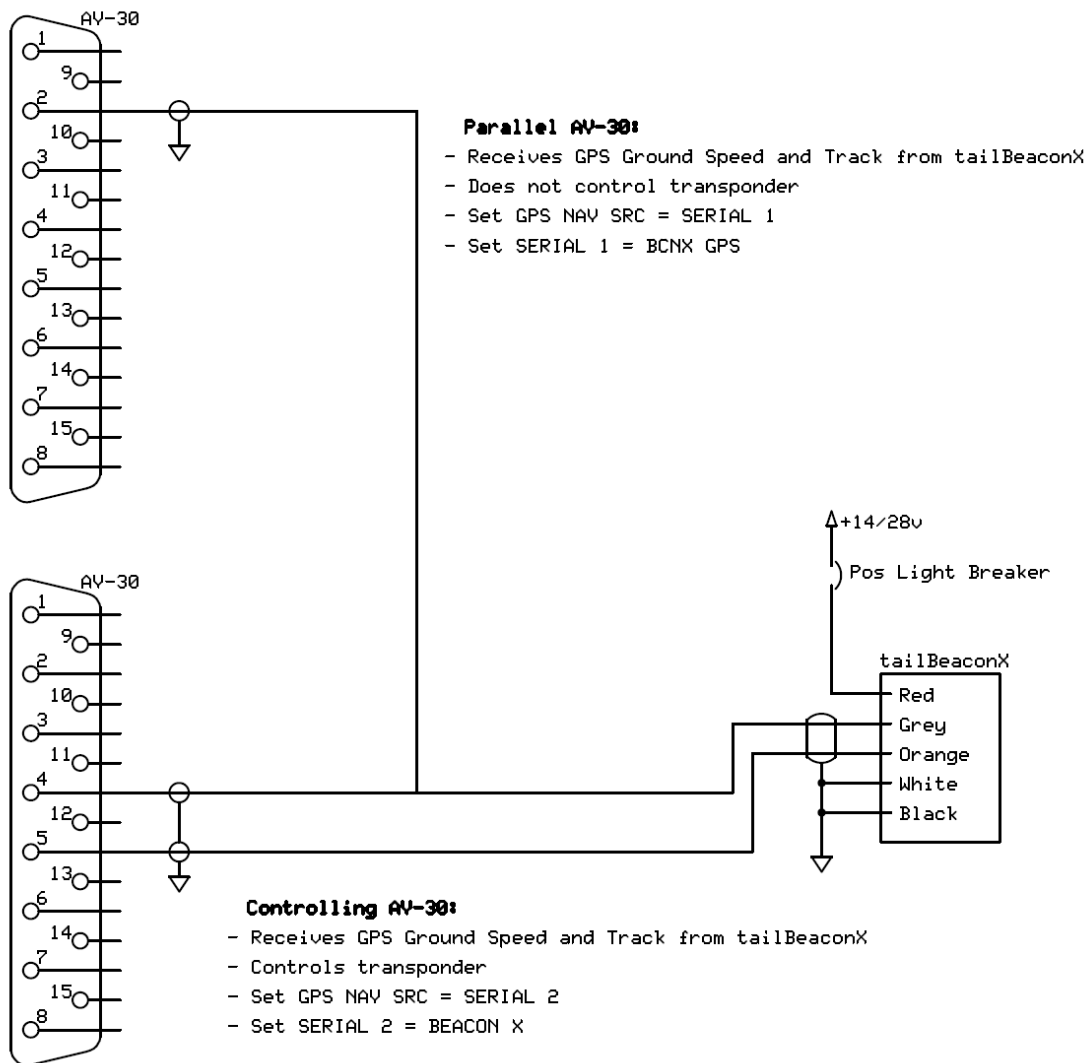

Figure 23 – Parallel tailBeaconX GPS Connections

10.2.1 Transponder Control

Transponder controls are enabled by selecting “BEACON X” on the “SERIAL 2” installation menu. See *AV-30-E Pilot’s Guide UAV-1004233-001* for transponder control interface configuration.

10.2.2 Transponder Testing with AV-30

Ground test mode may be initiated from the AV-30 via the following:

- Open the AV-30 installation menu and select BEACONX GTM (Ground Test Mode.)
- tailBeaconX will now respond to All-Calls on transponder test sets.
- When test is complete, cycle tailBeaconX power to exit test mode.

10.3 AV-Mag External Magnetometer

10.3.1 Magnetometer Overview

AV-Mag external magnetometer (P/N UAV-1006321-001) is a 3-axis electronic compass. It can precisely measure the earth's magnetic field and aid the AV-30 gyroscopic heading measurement, improving long-term accuracy.

For the AV-Mag to be effective, the installation and calibration must be done with accuracy and precision.

10.3.2 System Function

The AV-Mag, when paired with an AV-30, can provide consistent and accurate heading. The AV-Mag is an aiding device and does not provide full slaving to the AV-30.

10.3.3 AV-Mag Specifications

The AV-Mag specifications are as follows:

Characteristics	Specifications
Part Number	UAV-1006321-001
Width	1.49 Inches
Height	0.67 Inches
Depth	2.38 Inches
Weight	1.4 oz (40.0 grams)
Operating temperature range	-40°C to +70°C
Maximum pressure altitude	35,000 ft
Input voltage range	7 VDC typical (from AV-30 auxiliary power output)
7V current	12 mA typical

Table 9 – AV-Mag Specifications

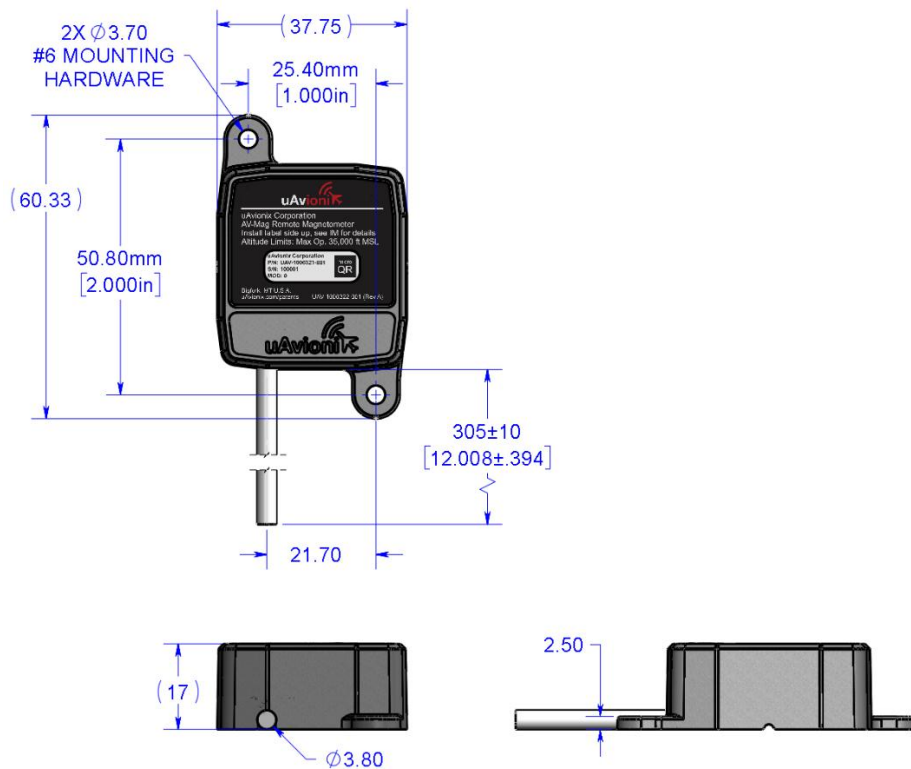

Figure 24 – AV-Mag Mechanical Drawing

Wire	Function	AV-30 pin
Red	+7 VDC Power	13
Black	Ground	10
Brown	Tx Data (AV-Mag → AV-30)	6
Green	Reserved serial input	NC
Blue	Reserved serial output	NC
White	Reserved serial input	NC

Table 10 – AV-Mag Wiring Guide

10.3.4 AV-Mag Software

The software contained in the AV-Mag device is identified by electronic marking. Software version information is sent in a serial message after power-up. The first screen of the AV-Mag installation menu shows the current AV-Mag software version and CRC (see §10.3.8). If AV-Mag is not properly connected, the version will indicate “Not detected”.

10.3.5 AV-Mag Installation Overview

An overview of the installation process is provided below. Detailed instructions are later in this section.

Step	Action	Verification
Connect and configure	Red wire => pin13 Black wire => pin 10 Brown wire =>pin 6 SERIAL4 => AVMAG (*Dual AV-30 parallel AV-Mag wiring shown in Appendix A: Example Wiring Schematics)	Red “NO MAG” flag indicates a bad connection Red “MAG CAL” flag indicates the connection is good and calibration is needed
Locate and mount	Set the AV-Mag mounting orientation in the AV-30 Interference check < 10%	N/A
Calibrate	AVMAG CAL operation On ground, 12-heading measurement	Red “MAG CAL” flag disappears Verify heading on ground
Record	Orient the aircraft to the 12 headings used in calibration	Record the results

Quick Installation Instructions

1. Wire and position the AV-Mag

- a. Identify a potential mounting location in the tail or wings.
 - b. Run wires from the AV-30 to the mounting location and connect to the AV-Mag.
2. Configure the AV-30
- a. In the AV-30 installation menu, set SERIAL 4 to AVMAG to enable the AV-Mag.
 - b. Enter the AV-Mag installation sub-menu (AVMAG INSTL) found in the AV-30 installation menu.
 - c. Check the mounting location for magnetic interference using the interference monitor in the AVMAG INSTL menu.
 - If magnetic interference is excessive at the mounting location, select a different mounting location.
 - d. Mount and align the AV-Mag using brass screws.
 - e. Enter the orientation of the AV-Mag according to Table 11 – AV-Mag Orientation Options.
 - f. Adjust AV-Mag mounting angles to match AV-30 mounting angles as displayed on the AV-30.
 - If necessary, build a bracket for the AV-Mag for mounting in the correct orientation and alignment.
 - AV-Mags can report their own roll and pitch angles to the AV-30. Those angles are visible on the second to last screen of the AV-Mag installation
3. Perform AV-Mag Calibration
- a. Run a calibration procedure on the installed AV-Mag and AV-30.
 - b. Perform the AV-Mag calibration check per §12.2.4.

Record your work in the provided tables and aircraft logbook.

10.3.6 AV-Mag Installation Materials and Tools

AV-Mag installation requires access to these tools:

- Non-magnetic Screwdriver and wrench

- Fish tape for pulling wire from cockpit through wing and fuselage structures
- Drill and drill bit
- Brass fasteners
- (Optional) Non-magnetic digital level or digital protractor/angle gauge. For example: Johnson Level & Tool 1886-0000 Magnetic Digital Angle Locator (unscrew the back of the case to remove the built-in magnets)

10.3.7 Additional Required Equipment

AV-Mag is designed to interface with an existing AV-30 display.

10.3.8 Enable the AV-Mag

Use of the AV-Mag is enabled through the AV-30 installation menu.

Before applying power, push and hold the center rotary knob and apply power. As the AV-30 splash screen appears, check that a minimum version of 2.3.0 is displayed. AV-Mag support is not available on units with software versions prior to 2.3.0.

Enter the AV-30 installation menu and navigate to the serial 4 interface option (SERIAL 4). Set SERIAL 4 to AVMAG.



While SERIAL 4 is set to AVMAG, the AHRS aiding mode (AID MODE) will automatically be set to AVMAG and cannot be changed.



Enter the AV-30 installation menu again and navigate to the AV-Mag installation menu (AVMAG INSTL). Push the center rotary knob, then press the right button to begin the installation process. If AV-Mag is not properly connected, the version will indicate “Not detected” and the red “NO MAG” flag will flash.



10.3.9 (Section removed)

10.3.10 AV-Mag Installation Location and Interference Monitor

Identify a mounting location on the aircraft. Suitable mounting locations include the tail and either wing. The cockpit is an unsuitable mounting location for the AV-Mag.

Proximity to ferrous materials and current-generated magnetic fields can negatively affect AV-Mag performance. Avionics, engines, wing spars, pitot heaters, lights, etc. are all potential sources of interference. Any interference which varies during flight may generate erroneous headings

from the AV-Mag. Because of this, the installation location should be as far as practical from these types of interferers. Inspect existing wiring near the installation location and repair or refresh any deteriorated insulation or corroded connections. Because wire loops generate magnetic fields, avoid locations near wires forming physical loops.

The fourth screen of the AVMAG INSTL menu is a magnetic field interference monitor with a checklist of aircraft systems which may be sources of interference.



Use the rotary knob to step through each system in the checklist and monitor the magnetic field deviation value.



The deviation value indicates the magnitude and direction of the magnetic reading with respect to the Earth's magnetic field. A relatively small deviation near zero indicates little or no magnetic field interference, while a larger negative or positive deviation indicates the AV-Mag is sensing magnetic fields in addition to the Earth's magnetic field.

At the end of the checklist, a REVIEW screen identifies which systems caused the largest deviations. Identifying systems that cause interference, especially those that generate temporary magnetic fields, can aid in proper site selection for installing the AV-Mag. The interference range indicates fluctuating magnetic fields which will negatively impact calculated magnetic heading values, so a good installation requires this range to be as small as possible. If the range is greater than 10%, attempts should be made to re-site the AV-Mag location or to mitigate interferers.



10.3.11 AV-Mag Installation Orientation and Attitude

The AV-Mag can be installed in a number of orientations. The chosen installation orientation must be entered into the fifth page of the AVMAG INSTL menu according to Table 11 – AV-Mag Orientation Options.

Figure 25 depicts the label and wire directions referenced in the table.



Menu Option	Label direction	Wire direction
LUP+WAFT	Upward (facing up)	Toward tail (wires aft)
LUP+WFOR	Upward	Toward nose (wires fore)
LUP+WLT	Upward	Toward left wingtip (wires port)
LUP+WRT	Upward	Toward right wingtip (wires starboard)
LDN+WAFT	Downward (facing down)	Toward tail
LDN+WFOR	Downward	Toward nose
LDN+WLT	Downward	Toward left wingtip
LDN+WRT	Downward	Toward right wingtip
LRT+WAFT	Right wingtip (facing starboard)	Toward tail
LRT+WFOR	Right wingtip	Toward nose
LRT+WUP	Right wingtip	Toward sky (wires upward)
LRT+WDN	Right wingtip	Toward ground (wires downward)
LLT+WAFT	Left wingtip (facing port)	Toward tail
LLT+WFOR	Left wingtip	Toward nose
LLT+WUP	Left wingtip	Toward sky
LLT+WDN	Left wingtip	Toward ground
LFOR+WUP	Forward (facing nose)	Toward sky
LFOR+WDN	Forward	Toward ground
LFOR+WLT	Forward	Toward left wingtip
LFOR+WRT	Forward	Toward right wingtip
LAFT+WUP	Aft (facing tail)	Toward sky
LAFT+WDN	Aft	Toward ground
LAFT+WLT	Aft	Toward left wingtip
LAFT+WRT	Aft	Toward right wingtip

Table 11 – AV-Mag Orientation Options



Figure 25 – AV-Mag Orientation Reference

In addition to the installation orientation, the mounting attitude of the AV-Mag must be determined as well. Though a small amount of angular mismatch between the installation attitudes of the AV-Mag and AV-30 is tolerable, the AV-Mag is ideally installed with the same roll, pitch, and yaw as the AV-30.

To match angles of the two devices, reference the fifth page of the AVMAG INSTL menu, which displays the roll and pitch angles of the AV-30 as mounted in the aircraft.

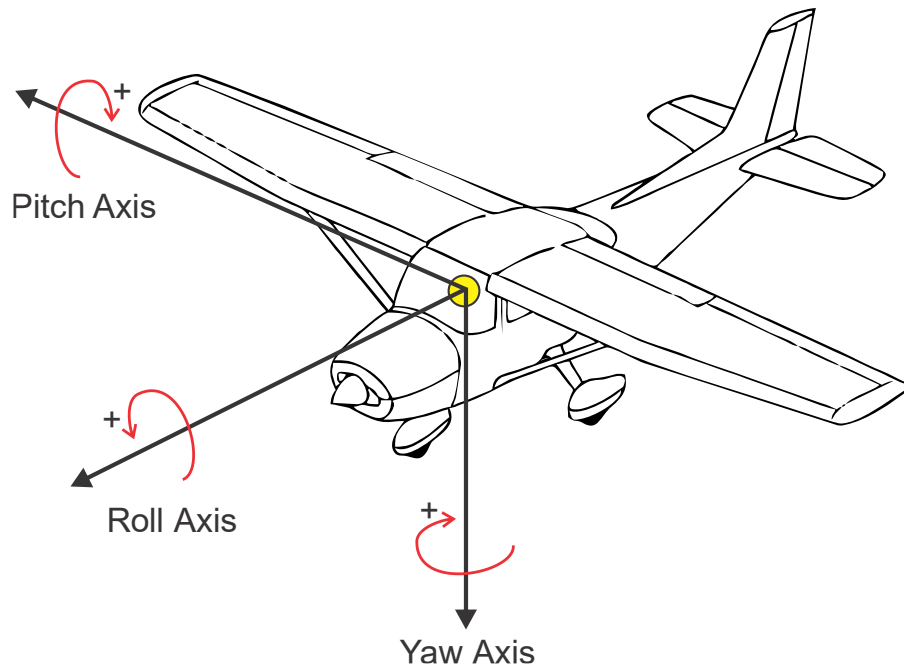

Adjust the AV-Mag mounting attitude to match that of the AV-30 as closely as possible. Simultaneously, the AV-Mag should be oriented as parallel to the line of flight as possible.

If prompted, enter the roll angle and pitch angle as measured with the digital level on the case of the AV-Mag into the next two pages of the AVMAG INSTL menu. Newer AV-Mags are self-measuring and these

pages are skipped. These AV-Mag attitude angles can be reviewed and committed on the second to last page. It is critical that the aircraft not be moved between measuring and entering the angles.



Once these values are committed, the AV-30 will calculate the differences in mounting angles for use in the heading solution. Once entered, changing these values without remeasurement of the AV-Mag angles will invalidate the installation calculation.



After roll and pitch angles have been entered, calibration may begin. Record the installation selections and parameters in Table 35 – AV-Mag Installation Parameters



10.3.12 AV-Mag Calibration

Calibration is the process of detecting and compensating for minor magnetic field and ferrous material interferences coming from the aircraft. If the AV-Mag is relocated or is removed and reinstalled, a re-calibration must be performed. AV-Mag orientation, roll and pitch installation angles, must be up-to-date at the time of calibration.

When calibration needs to be performed, in the absence of other flags, a red flag (MAG CAL) will appear.



Figure 26 – MAG CAL Flag and AVMAG CAL Selection

Prior to calibration, complete all installation and measurement steps from §10.3.11 AV-Mag Installation Orientation and Attitude. Failure to complete all installation steps will result in an invalid calibration.

The calibration menu appears as AVMAG CAL in the AV-30 installation menu. The calibration process requires the aircraft with AV-30 and AV-Mag installed to be oriented to each of 12 headings, with a 10 second measurement time at each orientation. Any interfering systems that must be on during flight (e.g., navigation lights) must also be on during calibration.

When AV-Mag is connected in parallel to multiple AV-30, calibration must be completed on each connected AV-30. Simultaneous calibration is recommended.

1. The external magnetometer calibration feature is found in the install menu. Hold down the center button while applying power. The installation menu can now be accessed until the next power cycle.
2. Move the aircraft to a location that is as level as possible and is far from power lines, metal structures, or reinforcement steel underground or nearby.
3. Enter the INSTALL menu and select AVMAG CAL, then press CALIB. Note that on units without an external magnetometer, AVMAG CAL will be disabled.



Figure 27 – AVMAG Calibration Entry

NOTICE

The aircraft will need to be oriented to twelve headings, each separated by 30 degrees. Calibration is sensitive to the angle between each of the heading orientations; if an accurate airfield compass rose is not available, measurements for each turn can be obtained using a calibrated magnetic compass or an electro-mechanical gyro. The AV-30 will also provide an on-screen turning guide to each calibration point.

4. Follow the on-screen instructions, pressing the right button once the aircraft is oriented to heading 360. Keep the aircraft as motionless as possible while the “Calibration in progress” message is displayed.



Figure 28 – AVMAG CAL In-Progress

5. Repeat step 4 for each orientation as directed by the on-screen instructions. The bottom-center display indicates the degrees and direction to the next orientation and will turn green when the aircraft is oriented correctly.



Figure 29 – AVMAG CAL Orientation Guide

6. Upon completion, the raw data will be processed. If a good calibration is possible, the red MAG CAL flag will extinguish, and the screen shall display a success message. If the calibration failed, please review the procedure and execute it again.



Figure 30 – AVMAG CAL Success and Failure Screens

The AV-30 will retain all magnetometer calibration data even if a hard reset is executed. Internal magnetometer and external magnetometer calibration data are stored independently.

10.3.13 AV-Mag Yaw Angle

Upon completion of calibration, the displayed heading at each of the 12 orientations should be checked and recorded in Table 36 – Calibrated Heading Check. If every heading is off by the same value, then the yaw angle of the installed AV-Mag may be imperfectly aligned with the aircraft line of flight or the alignment of the aircraft to magnetic north may be imperfect.

Generally, the DG adjustment should be used to compensate for any offset and the AV-Mag Yaw Angle setting should be left at 0.0. If required, uAvionix technical support may direct you to change the Yaw Angle value.



10.4 Autopilot Overview

The AV-30 can provide heading and course guidance to autopilots over three interfaces: analog, RS-232 Serial, or ARINC 429.

Legacy autopilots consuming an analog heading and course signal can be connected to the AV-30 using the AV-APA accessory.

The Trio Pro Pilot and Bendix King Aerocruze autopilots can be connected directly to the AV-30 using RS-232 serial, using the “Skyview” interface or using the ARINC 429 interface of an AV-HSI.

All three interface types allow the heading bug from the AV-30 to drive the autopilot heading mode. The AV-APA and RS-232 serial interface allow several GPS modes.

The Advanced Autopilot Software Unlock in conjunction with the AV-HSI enables GPS Steering (GPSS) commands from a panel mounted GPS receiver to drive autopilots using either of the three interfaces.

NOTICE

To provide the most accurate heading information for autopilot heading hold mode, it is strongly recommended that the AV-Mag be used in conjunction with the digital autopilot.

Below are descriptions of each interface. See the AV-30-E Pilot Guide for autopilot operation instructions.

10.4.1 AV-APA Analog Port Adapter

10.4.1.1 AV-APA Overview

The AV-APA emulates the analog heading signal used by legacy autopilots to provide basic heading hold as well as several directional control modes derived from GPS data.

To provide the most accurate heading information for heading hold mode, it is strongly recommended that the AV-MAG be used in conjunction with the AV-APA.

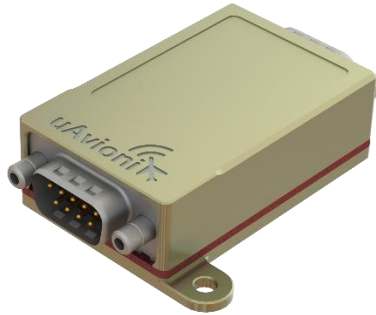

The AV-APA currently supports the following autopilots:

Manufacturer	Model
S-TEC / Genesys Aerosystems	System 20
	System 30
	System 40
	System 50
	System 55/55X
	System 60-1/60-2/65

Table 12 – Supported Autopilots

The AV-APA emulates the Bendix King KI-525A/KCS 55A heading output. If replacing a heading system other than the KCS 55A, the autopilot will need to be configured to accept KCS 55A signals. This involves changing programming resistors within the S-TEC control head. See an S-TEC authorized maintenance provider for details.

10.4.1.2 AV-APA Specifications

Characteristics	Specifications
Part Number	UAV-1006839-001
Width	2.2 Inches
Height	0.8 Inches
Depth	2.6 Inches
Weight	1.7 oz (48 grams)
Operating temperature range	-40°C to +70°C
Input voltage range	+10 to +32 VDC
14V current	.024 A typical
28V Current	.012 A typical

Table 13 – AV-APA Specifications

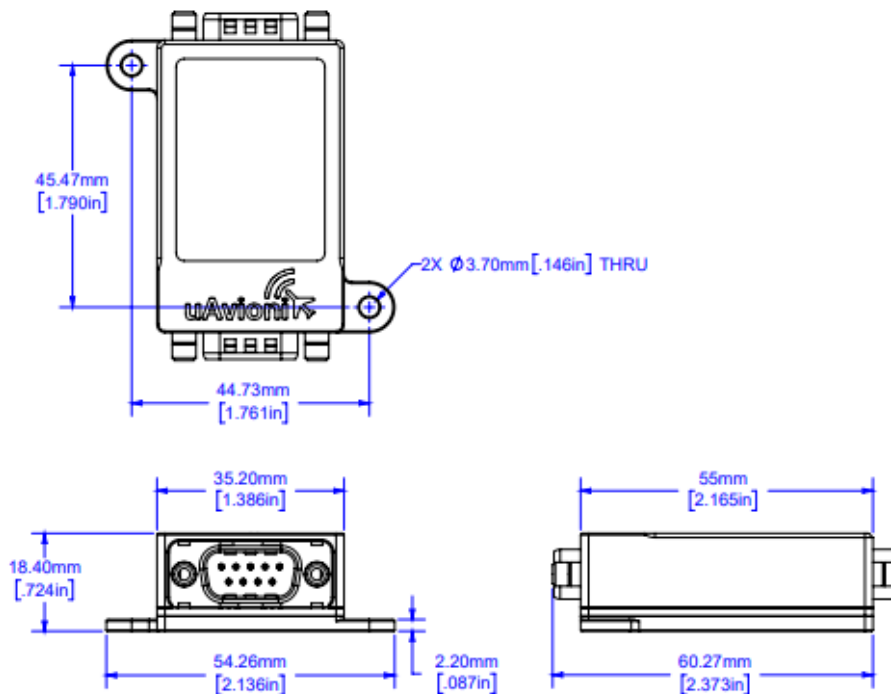

Figure 31 – AV-APA Mechanical Drawing



AV-30 Connector J2 (male)	Autopilot Connector J8 (female)
	

Figure 32 – AV-APA Connectors

NOTICE

Wiring the AV-APA backward may cause damage to the AV-APA, AV-30, and Autopilot. Take note of the connector orientation and gender to ensure the proper connectors are used.

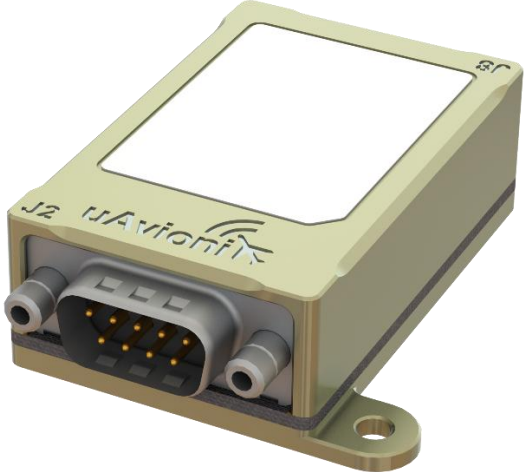
PIN	Function
AV-30 Connector Pin 1	Power
AV-30 Connector Pin 2	No Connect
AV-30 Connector Pin 3	RS-232 Port 1 In
AV-30 Connector Pin 4	RS-232 Port 1 Out
AV-30 Connector Pin 5	RS-232 Port 2 Out
AV-30 Connector Pin 6	RS-232 Port 2 In
AV-30 Connector Pin 7	No Connect
AV-30 Connector Pin 8	No Connect
AV-30 Connector Pin 9	Ground
Autopilot Connector Pin 1	Heading Offset Signal
Autopilot Connector Pin 2	Heading Excitation Signal 2
Autopilot Connector Pin 3	Heading Excitation Signal 1
Autopilot Connector Pin 4	No Connect
Autopilot Connector Pin 5	No Connect
Autopilot Connector Pin 6	Ground
Autopilot Connector Pin 7	+15V Reference
Autopilot Connector Pin 8	Course Datum Output
Autopilot Connector Pin 9	Heading Datum Output

Table 14 – AV-APA Pinout

10.4.1.3 AV-APA Installation Overview

An overview of the installation process is provided below. Further detail for the process may be found later in this document.

1. Configure the AV-30.
 - a. In the AV-30 installation menu, set SERIAL 2 to AV-APA to enable AV-APA functionality in the AV-30.
 - b. In the AV-30 installation menu, set the appropriate autopilot type under the 'AV-APA CFG' option.
 - c. If using the serial pass-through capability of the AV-APA, select the connected device in the 'AV-APA THRU' option.
2. Wire and mount the AV-APA
 - a. Identify the mounting location.
 - The AV-APA should be mounted to something rigid in a location that does not interfere with flight control movement.
 - The AV-APA is not waterproof; it must be mounted in a dry location.
 - b. Wire the AV-APA to the AV-30 and autopilot as described below. Detailed information about your autopilot can be found in your autopilot's installation manual.
 - c. Mount the AV-APA using appropriate fasteners. Fastener length and type will vary by installation and are therefore not provided in the installation kit. Use AC 43.13-1B for guidance.
3. Perform a ground checkout.
 - a. Perform a ground checkout as described below and as described in your autopilot installation manual.

Record your work in the aircraft logbook.

10.4.1.4 AV-APA Installation Materials and Tools

AV-APA installation kit includes the following components:

- One 9-pin D-Sub socket connector and shell
- One 9-pin D-Sub pin connector and shell
- M39029/63-368 sockets
- M39029/64-369 pins
- Ring terminals for shield termination

The following additional components will be required:

- Two conductor shielded wire, 22 or 24-gauge, M27500-22TG2T14 or M27500-24TG2T14
- Single conductor power and ground wire, 22 or 24-gauge, MIL-W-22759/16 or equivalent
- Pins for the autopilot connector. See autopilot installation manual for specification
- #8 fasteners appropriate to mount AV-APA to airframe

The AV-APA installation kit includes machined pins. These pins should be crimped with a Daniels AFM8 crimp tool using a K13-1 positioner, or equivalent M22520/2-01 crimp tool

10.4.1.5 Configure the AV-30 for the AV-APA

Use of the AV-APA is enabled through the AV-30 installation menu.

Before applying power, push and hold the center rotary knob and apply power. When the AV-30 splash screen appears, check that a minimum version of 2.4.1 is displayed. AV-APA support is not available on units with software versions prior to 2.4.1.

Enter the AV-30 installation menu and navigate to the serial 2 interface option (SERIAL 2). Set SERIAL 2 to AV-APA.



Navigate to AV-APA configuration option (AV-APA CFG) and select the appropriate autopilot that will be connected.



If connecting a device to the AV-APA pass-through port, navigate to the AV-APA passthrough option (AV-APA THRU) and select the appropriate device that is connected.

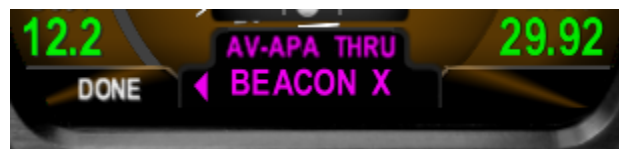

Press the left (DONE) button to exit the installation menu.

If using GPS Steering provided by the Advanced Autopilot Software Unlock, but turns in flight are too aggressive or not aggressive enough, the GPSS Gain can be adjusted. The default is 1.0. Adjust the gain upward by small increments and then test in flight to make the autopilot turn more aggressively. Adjust the gain downward for more shallow turns.



10.4.1.6 AV-APA Wiring and Autopilot Configuration

The AV-APA analog output emulates the heading output of the Bendix King KI-525A HSI within the KCS-55A system.

Ensure that your S-TEC control head (or GPSS module, if equipped) is configured to use the KCS-55A. This will be stamped on a label on the autopilot control head or GPSS module.

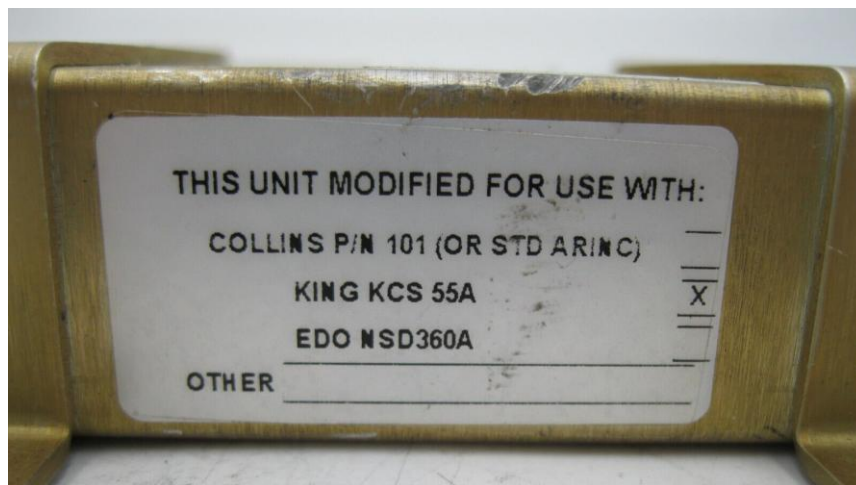
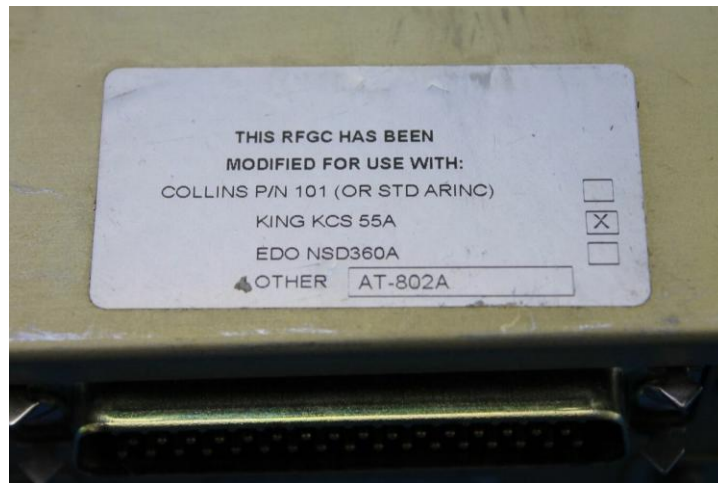

If your autopilot system is not configured to accept the KING KCS 55A input, see an authorized S-TEC dealer for modification.

Once confirming that the autopilot is configured correctly, use the following wiring diagrams to build a harness:

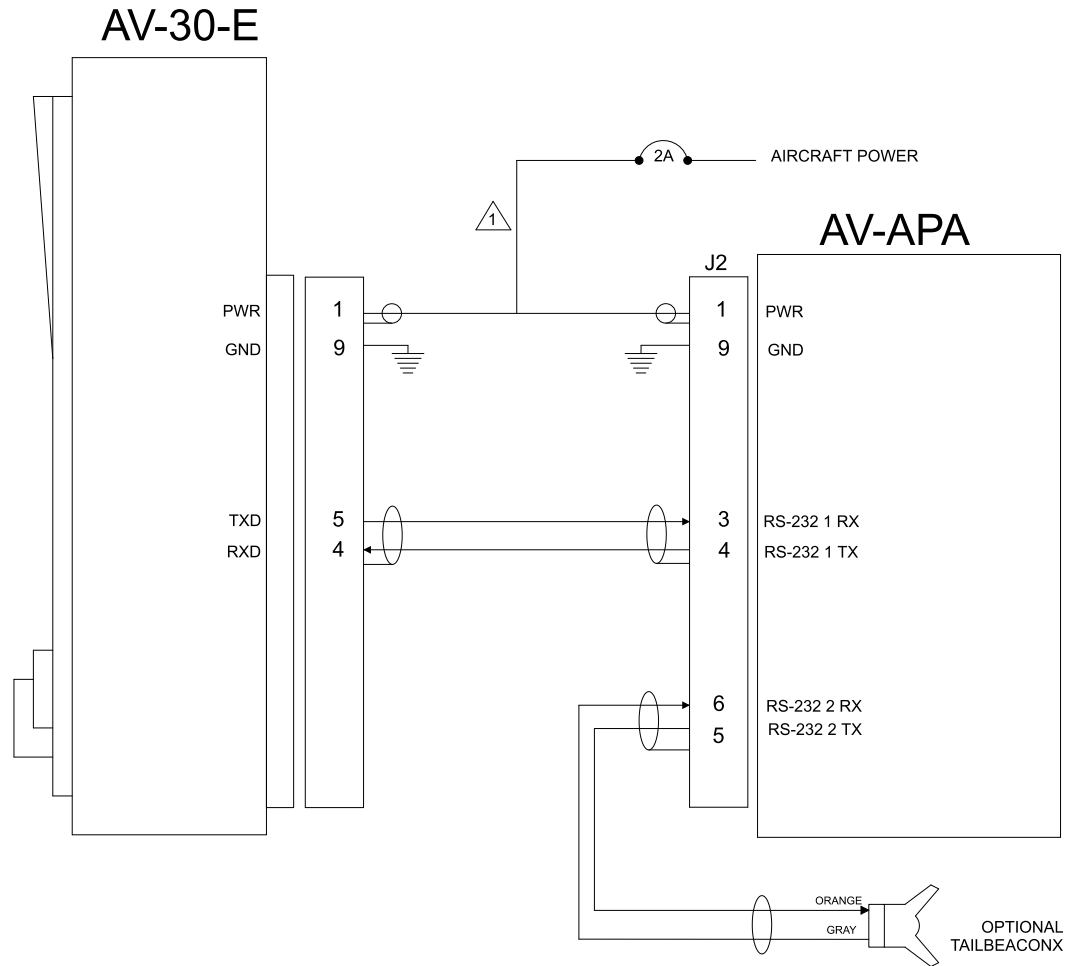

NOTES:

1. THE AV-APA MAY SHARE A 2A CIRCUIT BREAKER WITH AN AV-30.
2. USE 22 OR 24 AWG MIL-C-27500 WIRE.
3. WIRE SHIELD SHOULD BE TERMINATED TO THE D-SUB MOUNTING SCREW.

Figure 33 – AV-APA – AV-30 Interconnect Drawing

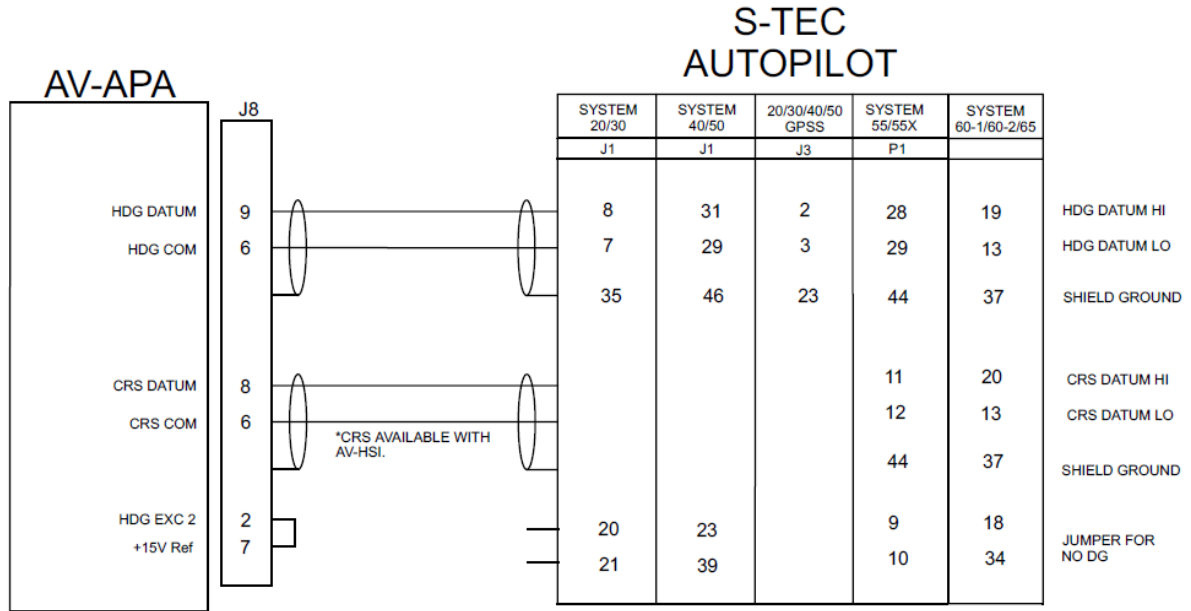

NOTES:

1. USE 22 OR 24 AWG MIL-C-27500 WIRE.
2. CONNECT TO GPSS CONVERTER IF PRESENT, AUTOPILOT COMPUTER IF GPSS CONVERTER IS NOT PRESENT. DO NOT CONNECT TO BOTH.
3. HDG AND CRS DATUMS SIMULATES A KI-525A HSI. IF REPLACING HEADING REFERENCE OTHER THAN KI-525A THEN THE AUTOPILOT NEEDS TO BE MODIFIED TO ACCEPT KI-525A SIGNALS. SEE S-TEC REFERENCE MATERIAL.
4. SEE S-TEC DOCUMENTATION FOR INTEGRATION INFORMATION AND CHECKOUT PROCEDURES.
5. COURSE (CRS) DATUM OUTPUT IS ONLY AVAILABLE IF INSTALLED WITH AN AV-HSI.

Figure 34 – AV-APA – S-TEC Interconnect

Ground wire shields to AV-APA connector backshells as depicted in Figure 15 – Shielded Cable and Figure 16 – Cable Shields and Ground Strap.

Secure harness to the AV-APA using the included screws.

10.4.1.7 Ground Checkout

See checkout guidance in §12.2.11.

10.4.2 RS-232 Autopilots

The RS-232 autopilot interface supports the BendixKing AeroCruze 100/xCruze 100/TruTrak Vizion (385 and PMA) or the Trio Pro Pilot.

NOTICE

For complete AeroCruze installation guidance, see Installation Guide For Vizion PMA Autopilot, Trutrak Doc: 166 and Vizion Series Autopilots Dynon SkyView Interface Supplement 8300-087 Rev IR.

For complete Trio Pro Pilot installation guidance, see the Trio Avionics Pro Pilot Manual for Experimental Aircraft. The AV-APA is not powered by the AV-30 internal battery. Analog autopilot operations will be unavailable during a power loss.

Select 'AEROCRUZE' or 'PRO PILOT' in the Serial 2 installation menu. The serial baud rate is set to match the autopilot default of 9600, N, 8, 1 and is not manually configurable.

10.4.2.1 RS-232 Autopilot Control

When using RS-232, the AV-30 controls heading, set altitude, and set vertical speed.

See *Operating Handbook for Vizion PMA Autopilot TruTrak Doc:167* for detailed operation of the AeroCruze/TruTrak autopilot.

See *Trio Avionics Pro Pilot Manual for Experimental Aircraft* for detailed operation of the Trio Pro Pilot autopilot.

- Power on the autopilot and sync the altimeter on the autopilot
- Leave the autopilot disengaged until the AV-30 is powered on and operational.

See *AV-30-E Pilot's Guide UAV-1004233-001* for detailed operation of the autopilot control interface.

10.4.2.2 RS-232 Autopilot Ground Checkout



Display Set Altitude (SALT)

- If the AV-30 is not already in AI mode, switch it to AI mode by pressing and holding the center knob to cycle through the available modes
- Select a display field in which to display Set Altitude (SALT). This is done by pressing and releasing the left button under 'Menu' and rotating the center knob until a blank field is selected
- Press and release the center knob to enable selection
- Rotate the center knob until 'SET ALT' is selected
- Press and release the center knob to save the selection
- Press and release the left button under 'Done'

Input SALT

- Press and release the center knob until 'SET ALT' appears

- Rotate the center knob to select an altitude
- Press and release the center knob to save



Input Set Vertical Speed (SVS)

- Subsequent to saving the SET ALT value, you should now be presented with a 'SET VS' input. Inputting a Set Altitude is always followed by inputting a Set Vertical Speed. If you do not get the 'SET VS' input prompt, go back to the installation menu and verify that SERIAL 2 is set to AEROCRUIZE or PRO PILOT.
- Turn the center knob to select a vertical speed
- Press and release the center knob to save the SVS value



Display the Heading Indicator

- If the horizontal DG indicator is not already displayed, use the following instructions
- Press and release the left button under 'Menu'. The field at the top of the inner circle will be highlighted
- Press and release the center knob to enable selection
- Rotate the center knob until 'DG HDG' is displayed
- Press and release the center knob to save the selection
- Press and release the left button under 'Done'



Display and Input the Heading Bug

- Press and release the center knob until 'HDG BUG' is displayed
- Rotate the center knob to adjust the heading bug
- Press and release the center knob to save the selection



Display the SVS Bug

- Press 'Menu' and rotate the center knob clockwise 4 clicks to select and enable the Vertical Trend indicator on the right side of the inner circle
- Press and release the center knob
- Rotate the center knob until 'V TREN' is selected
- Press and release the center knob to save the selection
- Press the left button under 'Done'

Engage the Autopilot

- To enable the connection to the autopilot, push and release the center knob until the 'AUTOPILOT' menu appears. Rotate the knob clockwise to select the HDG BUG mode.
- The AV-30 is now sending serial data to the autopilot.
- Engage the autopilot via the autopilot's controls.

AeroCruze verification steps

- Put the autopilot into SkyView mode by pressing and releasing the autopilot's Mode button. 'SKYVIEW' will appear in the upper left corner if the autopilot is receiving data from the AV-30.
- Verify that the autopilot 'ALT' display is the same as the selected altitude, 'SALT' on the AV-30.
- On the AV-30, change the 'SALT' and verify that the changed value appears on the autopilot 'ALT' display
- Verify that the autopilot 'Set VS' display is the same as the 'SVS' on the AV-30.
- On the AV-30, change the value of 'Set VS' and verify that the changed value appears on the autopilot 'SVS' display
- Verify that the autopilot 'SEL' display is the same as the heading bug 'HDG BUG' on the AV-30.
- On the AV-30, change the heading bug and verify that the changed value appears on the autopilot 'SEL' display
- On the autopilot, if using an AEROCRUZE, exit SkyView mode by pressing and releasing the autopilot's Mode button
- Disengage the autopilot via the autopilot's controls.

Pro Pilot verification steps

- On the AV-30, rotate the center knob to vary the barometric correction and verify that the Pro Pilot ELEVATION (ALTITUDE) set screen displays a setting that varies as the AV-30 barometric correction is varied.
- On the AV-30, change the 'SALT' and verify that the changed value appears on the autopilot 'ALTITUDE SET' display
- Verify that the autopilot 'VS Set' display is the same as the 'SVS' on the AV-30.

- Verify that the autopilot 'CMD' display is the same as the heading bug 'HDG BUG' on the AV-30.
- On the AV-30, change the heading bug and verify that the changed value appears on the autopilot 'CMD' display
- Disengage the autopilot via the autopilot's controls.

10.4.3 ARINC 429 Autopilots

The ARINC 429 autopilot interface uses the AV-HSI to provide inputs to the BendixKing AeroCruze 100/xCruze 100/TruTrak Vizion (385 and PMA) or the Trio Pro Pilot.

NOTICE

For complete AeroCruze installation guidance, see Installation Guide For Vizion PMA

For complete Trio Pro Pilot installation guidance, see the Trio Avionics Pro Pilot Manual for Experimental Aircraft.

The ARINC 429 interface on the AV-HSI sends selected heading, selected course, set altitude to the autopilot. Additionally, if the Advanced Autopilot Unlock is present, the AV-HSI can forward GPS Steering commands from a panel mounted navigator to the autopilot.

When using the ARINC 429 interface, vertical speed is set directly on the autopilot.

ARINC 429 transmits data at a higher rate than RS-232 and therefore provides a smoother autopilot experience than when using RS-232.

10.4.3.1 ARINC 429 Autopilot Installation

To interface the AV-HSI and AV-30 with an ARINC 429 autopilot, the ARINC 429 TX lines out of the AV-HSI are spliced to go to both the autopilot and the GPS navigator.

Autopilot wiring is as follows:

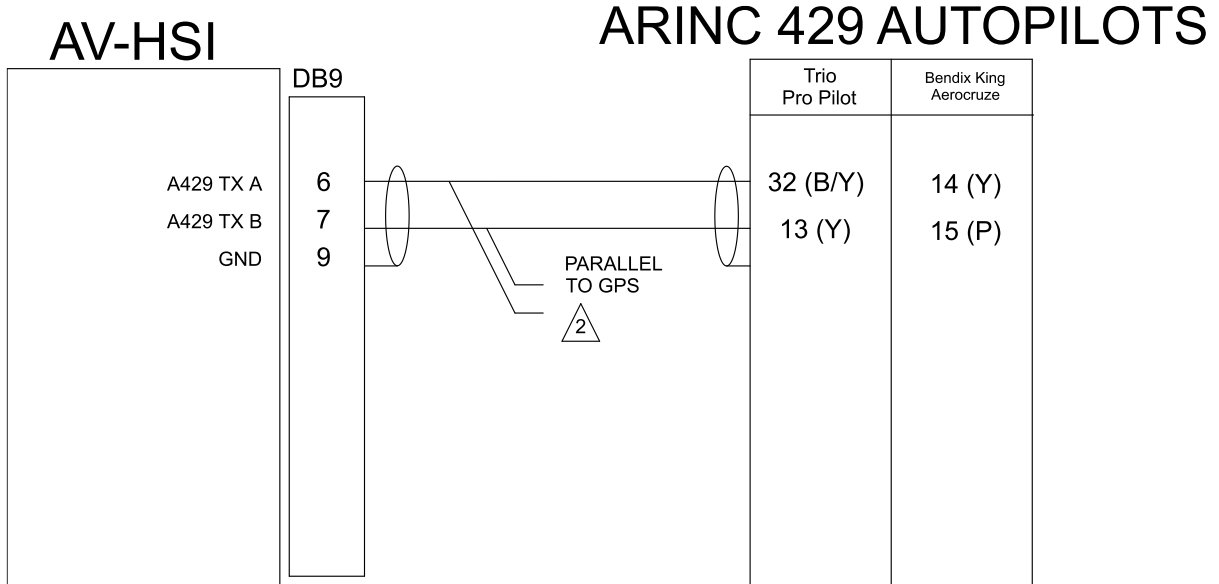

NOTES:

1. USE 22 OR 24 AWG MIL-C-27500 TWO CONDUCTOR SHIELDED WIRE.
2. SPLICE A429 TX A AND B TO CONNECT TO BOTH AUTOPILOT AND GPS NAVIGATOR, REFER TO FIGURE AV-HSI - ARINC 429 INTERCONNECT DRAWING FOR DETAILS

Figure 35 – AV-HSI – ARINC 429 Autopilot Interconnect

When not using the Advanced Autopilot Unlock, a DPDT switch is wired to select between GPS and AV-30 control of the autopilot. This wiring is as follows:

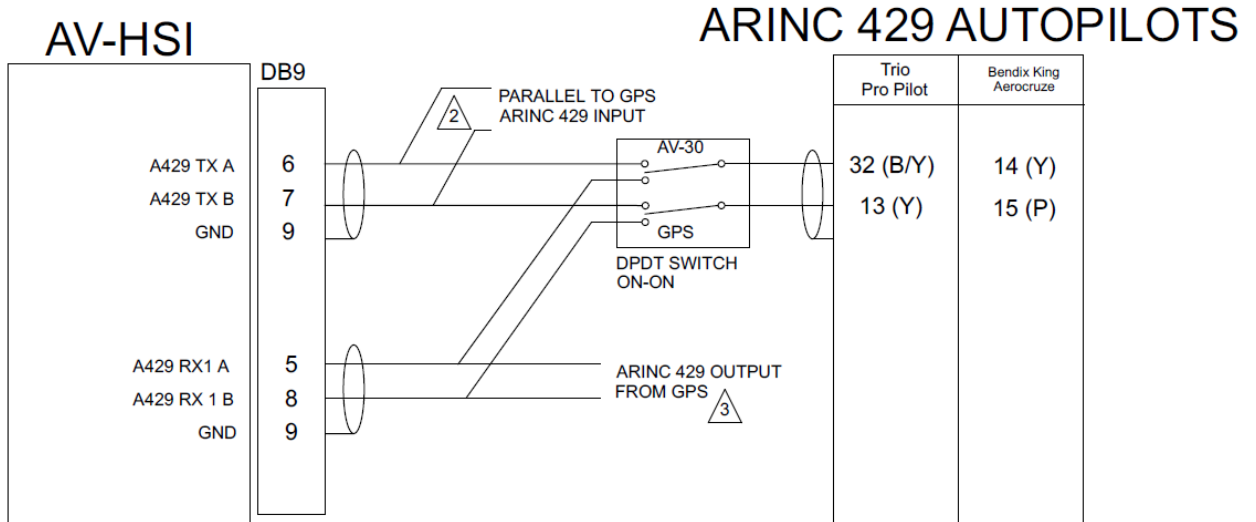

NOTES:

1. USE 22 OR 24 AWG MIL-C-27500 TWO CONDUCTOR SHIELDED WIRE.
2. SPLICE A429 TX A AND B TO CONNECT TO BOTH AUTOPILOT SWITCH AND GPS NAVIGATOR INPUT, REFER TO FIGURE AV-HSI - ARINC 429 INTERCONNECT DRAWING FOR DETAILS.
3. SPLICE A429 RX1 A AND B TO CONNECT TO BOTH GPS OUTPUT AND AUTOPILOT SWITCH.

Figure 36 – AV-HSI – Autopilot Interconnect Without Advanced AP Unlock

Refer to your autopilot installation manual for configuration details.
Recommended settings are:

Trio Pro Pilot	
In AV-30 AV-HSI Config: AP Type	1

Bendix King Aerocruze	
On Autopilot: EFIS Type	2 (See Aerocruze Installation Manual Lateral Settings for configuration instructions)
In AV-30 AV-HSI Config: AP Type	2

Perform ground checkout per your autopilot’s installation manual.

10.4.4 Advanced Autopilot Unlock

With the optional Advanced Autopilot Unlock, the AV-30 and AV-HSI can process GPS Steering (GPSS) messages from a panel mounted navigator. This processing enables the following, based on your autopilot interface:

Autopilot Interface	Capability Unlocked
AV-APA	Legacy analog autopilot connected to the AV-APA can follow GPS course from a panel-mounted navigator.
ARINC 429 through AV-HSI	AV-HSI forwards lateral and vertical GPS steering messages from the GPS to connected autopilots, negating the need for an external ARINC 429 switch.
RS-232	AV-30 commands the autopilot to follow the GPS course from the panel-mounted navigator.

The Advanced Software Unlock is performed by navigating to the “Advanced AP” option in the AV-30 installation menu.



When this option is selected, a QR code is presented. Use your mobile phone or tablet camera application to take a picture of the QR code and open the unlock website. From there, the unlock code can be purchased.

Once purchased, the unlock website will present an 8 character unlock code. This code is entered into the AV-30 by rotating the center knob to change the digit and pressing the center knob to advance to the next digit. Once the code is successfully entered, press the center knob again to validate. If the code validates correctly, the QR code will be removed, and the feature will be unlocked.

If using in an installation with multiple AV-30, only the AV-30 connected to the AV-APA or directly to the autopilot needs the Advanced AP Unlock. If using in an installation with the AV-HSI, only one AV-30 needs the unlock.

For safety, the QR code will not be presented if the AV-30 is indicating an airspeed or if the gyros are aligning.

10.5 AV-HSI Horizontal Situation Indicator

10.5.1 AV-HSI Overview

The AV-HSI enables course and glideslope guidance display on multiple connected AV-30s to enable GPS and ILS precision instrument approaches and enroute guidance.

The AV-HSI adds three ARINC 429 channels (2 receive, 1 transmit) to interface with most panel-mounted GPS navigators. In addition, the AV-HSI includes four serial ports that act as a hub between multiple AV-30s as well as supporting portable GPS and serial VOR/ILS receivers. The hub capability forwards navigation guidance to all connected AV-30s as well as synchronization of barometric pressure setting, transponder settings, heading bug, OAT, and autopilot modes. If an AV-Link is connected directly to the AV-HSI, this hub function also serves traffic, carbon monoxide alerts, and software updates from the AV-Link to all connected AV-30.

The AV-HSI may be connected to one GPS navigation source and one VHF navigation source, whether from one combined nav/com unit or from a standalone GPS navigator and VHF navigator. If the installer wishes to connect to multiple GPS navigators, multiple AV-HSI and independent AV-30s are required. This creates a fully redundant system.



NOTICE

Due to the precise nature of IFR navigation, using the AV-HSI in conjunction with the AV-Mag is strongly recommended.

The AV-HSI is compatible with the following GPS Navigators:

Manufacturer	Model
Avidyne	IFD 410/440
	IFD 510/540/545/550
Garmin	GPS 155XL/300XL
	GPS 500(w)/GNS 530(w)
	GPS 400(w)/GNC 420(w)/ GNS 430(w)
	GNS-480/CX80
	GPS 500(w)/GNS 530(w)
	GTN 625(xi)/635(xi)/650(xi)
	GTN 725(xi)/750(xi)
	GPS 175/GNC 355/GNX 375
Various	Portable NMEA GPS (Examples include Aera 660, GPSMAP 296/396/496). Note: these provide VFR-only guidance.

Table 15 – AV-HSI Compatible GPS Navigators

The AV-HSI is compatible with the following NAV/COMM or VOR/ILS Receivers:

Manufacturer	Model
Avidyne	IFD 440
	IFD 540/550
Garmin	GNS 430(w)/530(w)
	GTN 650(xi)/750(xi)
	GNC 215
	GNC 255
	Garmin/Apollo SL30
Trig	TX56(a)/TX57(a)
MGL	N16 (requires separate control head)
VAL	NAV 2000

Table 16 – AV-HSI Compatible NAV/COMM

Other navigators may be compatible if they support GAMA ARINC 429 output or the Apollo SL30 protocol.

10.5.2 AV-HSI Specifications

The AV-HSI dimensions and pinout are as follows:

Characteristics	Specifications
Part Number	UAV-1007412-001
Width	2.3 Inches
Height	.614 Inches
Depth	2.3 Inches
Weight	1.8 oz (50 grams)
Operating temperature range	-40°C to +70°C
Input voltage range	+10 to +32 VDC
14V current	.02 A typical
28V Current	.01 A typical

Table 17 – AV-HSI Specifications

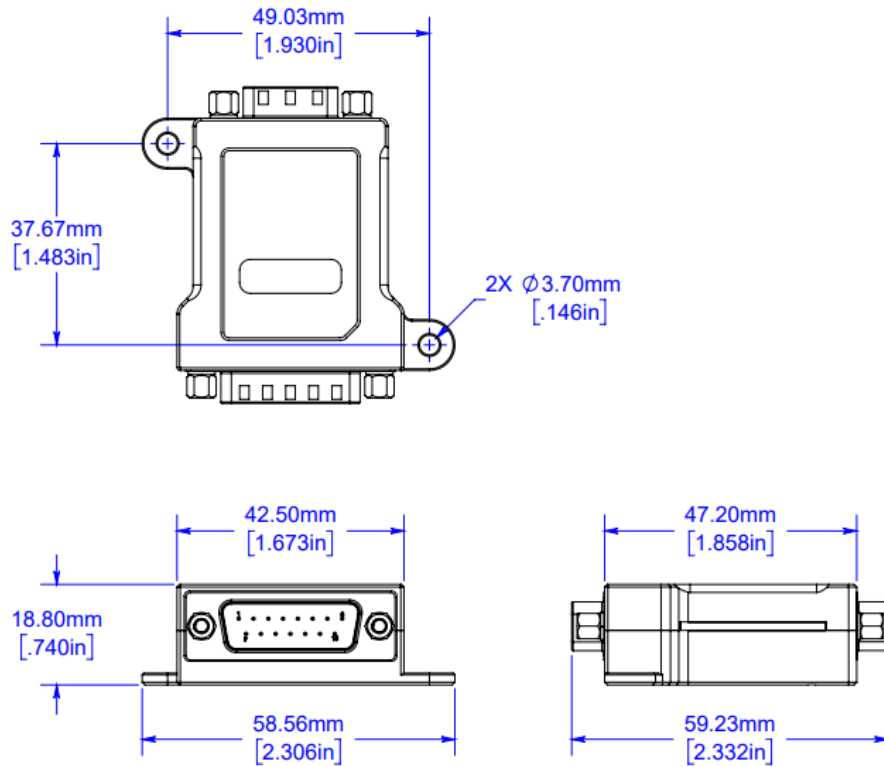

Figure 37 – AV-HSI Mechanical Drawing

PIN	Function
DB15 Pin 1	Power
DB15 Pin 2	RS-232 Port 1 In
DB15 Pin 3	RS-232 Port 1 Out
DB15 Pin 4	RS-232 Port 2 In
DB15 Pin 5	RS-232 Port 2 Out
DB15 Pin 6	RS-232 Port 3 In
DB15 Pin 7	RS-232 Port 3 Out
DB15 Pin 8	RS-232 Port 4 In
DB15 Pin 9	Ground
DB15 Pin 10	No Connect
DB15 Pin 11	No Connect
DB15 Pin 12	No Connect
DB15 Pin 13	No Connect
DB15 Pin 14	No Connect
DB15 Pin 15	RS-232 Port 4 Out

Table 18 – AV-HSI DB15 Pinout

PIN	Function
DB9 Pin 1	No Connect
DB9 Pin 2	No Connect
DB9 Pin 3	A429 RX Channel 2 A
DB9 Pin 4	A429 RX Channel 2 B
DB9 Pin 5	A429 RX Channel 1 A
DB9 Pin 6	A429 TX A
DB9 Pin 7	A429 TX B
DB9 Pin 8	A429 RX Channel 1 B
DB9 Pin 9	Shield Ground

Table 19 – AV-HSI DB9 Pinout

10.5.3 AV-HSI Installation Overview

An overview of the installation process is provided below. Further details for the process may be found later in this document.

1. Wire and mount the AV-HSI
 - a. Identify the mounting location.
 - The AV-HSI should be mounted to something rigid in a location that does not interfere with flight control movement.
 - The AV-HSI is not waterproof; it must be mounted in a dry location.
 - If connecting an AV-Link directly to the AV-30, ensure the location is large enough for both.
 - b. Wire the AV-HSI to the AV-30(s), navigators, and autopilot as described below. Detailed information about your navigator can be found in the navigator installation manual.
 - c. Mount the AV-HSI using appropriate fasteners. Fastener length and type will vary by installation and are therefore not provided in the installation kit. Use AC 43.13-1B for guidance.
2. Configure the AV-30(s) and AV-HSI
3. Perform a ground checkout
4. Record your work in the aircraft logbook.

10.5.4 AV-HSI Installation Materials and Tools

AV-APA installation kit includes the following components:

- One 15-pin D-Sub socket connector and shell
- One 9-pin D-Sub socket and shell
- M39029/63-368 sockets

The following additional components will be required:

- Two conductor shielded wire, 22 or 24-gauge, MIL-C-27500 or equivalent
- Single conductor power and ground wire, 22 or 24-gauge, MIL-W-22759/16 or equivalent
- Pins for navigator connectors. See navigator manual for specification
- #8 fasteners appropriate to mount AV-HSI to airframe
- One 9-pin D-SUB Female connector for an update harness

The AV-HSI installation kit includes machined pins. These pins should be crimped with a Daniels AFM8 crimp tool using a K13-1 positioner, or equivalent M22520/2-01 crimp tool.

10.5.5 AV-HSI Wiring

Use the following wiring diagrams to build a harness:

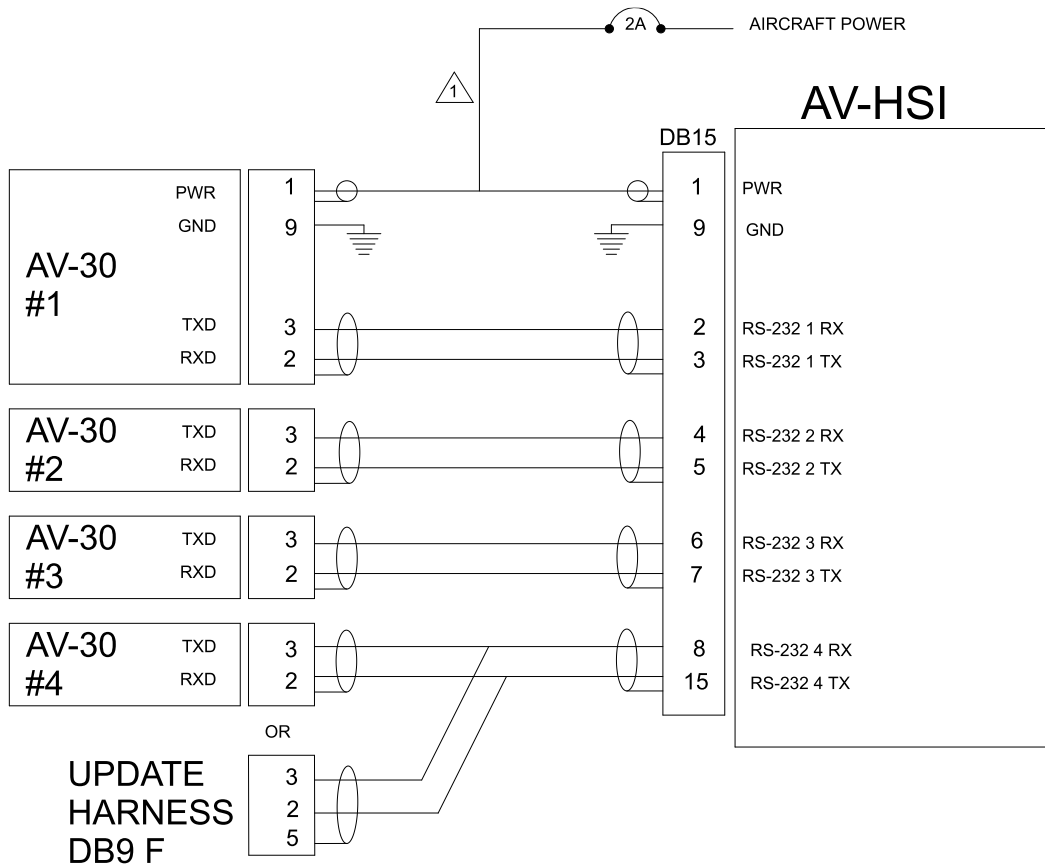

NOTES:

1. USE 22 OR 24 AWG MIL-C-27500 TWO CONDUCTOR SHIELDED WIRE.
2. AV-HSI RS-232 PORT 1 (PINS 2 AND 3) MUST BE CONNECTED TO AN AV-30. REMAINING THREE AV-HSI SERIAL PORTS MAY BE CONNECTED TO ADDITIONAL AV-30 OR TO A SERIAL NAVCOM.
3. UP TO 4 AV-30 MAY BE CONNECTED TO THE AV-HSI. ONLY ONE SERIAL NAVCOM MAY BE CONNECTED.
4. GROUND WIRE SHEILDS TO THE DB15 CONNECTOR RETAINING SCREW USING THE SUPPLIED RING TERMINAL.
5. AV-HSI RS-232 PORT 4 IS USED TO UPDATE THE AV-HSI. SEE IM INSTRUCTIONS FOR TERMINATING.

Figure 38 – AV-HSI – AV-30 Interconnect Drawing

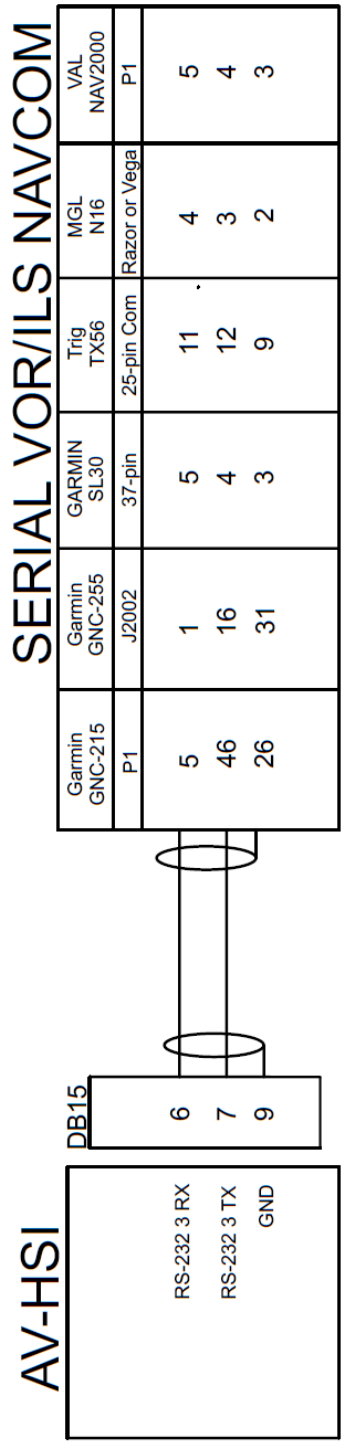

- NOTES:
1. USE 22 OR 24 AWG MIL-C-27500 TWO CONDUCTOR SHIELDED WIRE.
 2. RS-232 PORT 3 IS DEPICTED, THOUGH PORT 2 OR 3 MAY BE USED.
 3. ONLY ONE VHF NAVIGATION SOURCE MAY BE CONNECTED TO THE AV-HSI.
 4. OTHER VHF NAVIGATORS THAT SUPPORT THE APOLLO SL30 PROTOCOL MAY BE COMPATIBLE. REFER TO THEIR INSTALLATION MANUAL FOR PINOUT.

Figure 39 – AV-HSI – Serial NAVCOM Interconnect Drawing

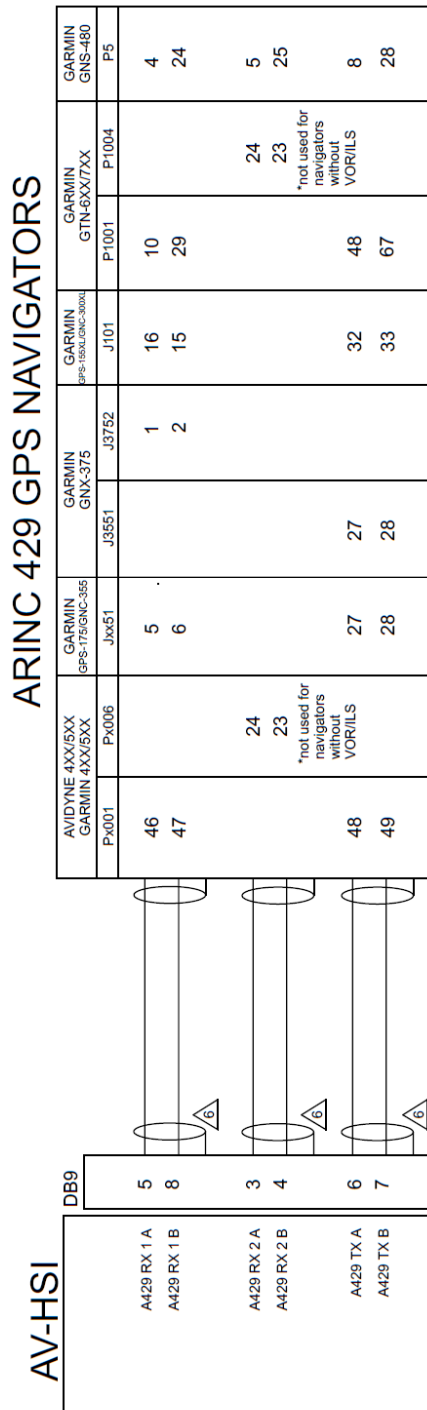

NOTES:

1. USE 22 OR 24 AWG MIL-C-27500 TWO CONDUCTOR SHIELDED WIRE.
2. SOME NAVIGATORS HAVE MULTIPLE CONFIGURABLE ARINC 429 CHANNELS. CHANNEL 1 IS DEPICTED HERE. OTHER APPROPRIATELY CONFIGURED CHANNELS MAY BE USED. CONSULT NAVIGATOR MANUAL FOR DETAILS.
3. ONLY ONE GPS SOURCE AND ONE VHF NAV SOURCE MAY BE CONNECTED TO THE AV-HSI.
5. OTHER NAVIGATORS USING ARINC 429 MAY BE COMPATIBLE. REFER TO THEIR INSTALLATION MANUALS FOR PINOUT.
6. GROUND WIRE SHIELDS TO THE DB9 CONNECTOR RETAINING SCREW USING THE SUPPLIED RING TERMINAL.

Figure 40 – AV-HSI – ARINC 429 Interconnect Drawing

Secure harnesses to the AV-HSI using the included screws.

Secure the AV-HSI to your airframe or panel using appropriate fasteners, ensuring the AV-HSI and wiring does not interfere with flight controls.

10.5.6 AV-HSI Update Harness

The AV-HSI software can be field updated. Provisioning the AV-HSI with a 9-Pin D-SUB Female serial update harness at an accessible location is recommended. Refer to Figure 41 – AV-HSI Update Harness for details.

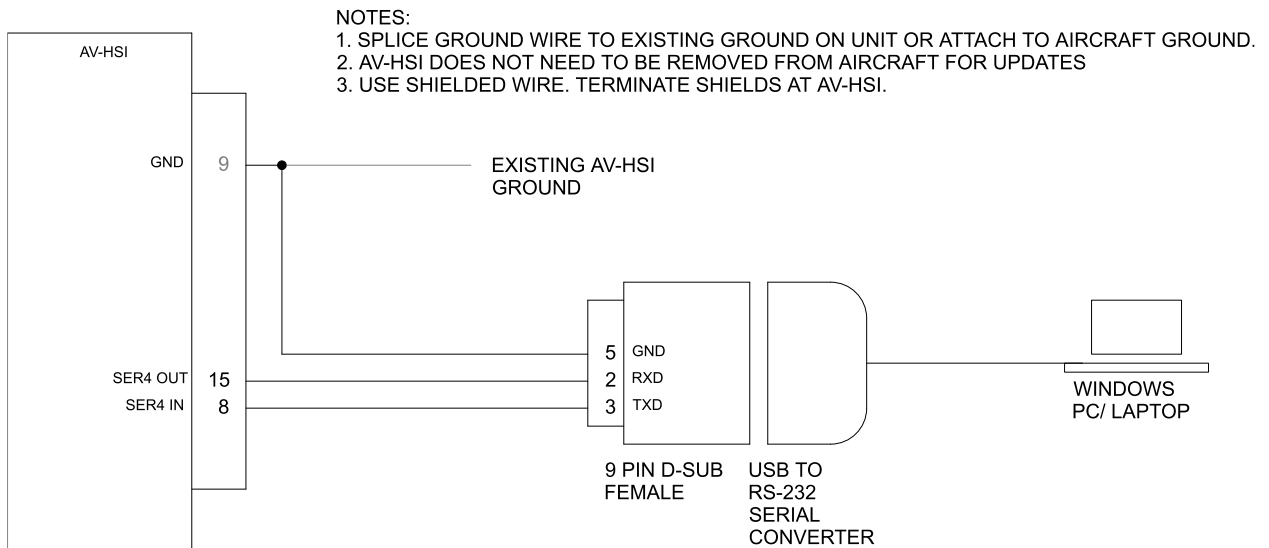

Figure 41 – AV-HSI Update Harness

AV-HSI Serial 4 (Pins 8 and 15) is used for updates. Serial 4 may also be used to connect an additional AV-30 to the AV-HSI. If Serial 4 is used for an AV-30, the installer should consider installing an easy disconnect on the serial line to make AV-HSI Serial 4 accessible for updates. Refer to Figure 42 – AV-HSI Update With AV-30 Using Serial 4 for details.

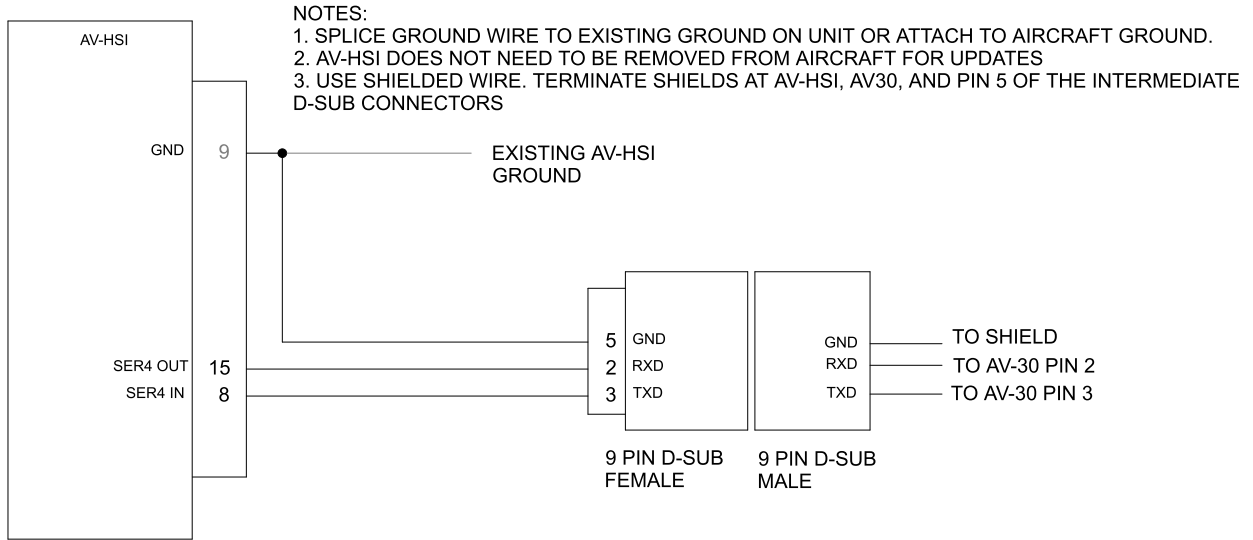
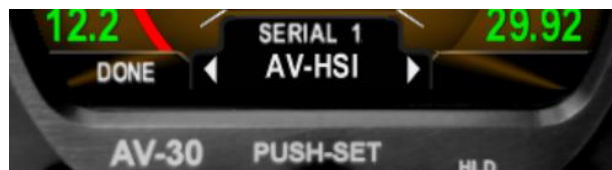

Figure 42 – AV-HSI Update With AV-30 Using Serial 4

10.5.7 AV-HSI/AV-30 Configuration

Each connected AV-30 must be configured to use the AV-HSI. On each AV-30 in the installation menu, set SERIAL 1 to AV-HSI and GPS NAV SRC to SERIAL 1 by pressing the center knob to select the item and rotating the center knob to change the option. Pressing the center knob again sets the option.



Configuration of the AV-HSI is performed through the AV-30 Installation Menu, under the heading AVHSI CFG. This menu appears in white and is selectable if the AV-30 detects a connected AV-HSI. Select by pressing the center knob.

If the menu item is grey this indicates that the AV-HSI and AV-30 are not communicating. Confirm the above step was performed successfully and confirm correct wiring.

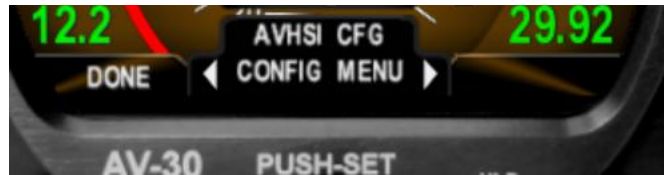

The AV-HSI CFG submenu contains the following options:

Configuration Item	Options	Description
SERIAL 2	AV-30, NAVCOMM, NMEA 4800, NMEA 9600	<p>The device type connected to SERIAL 2.</p> <p>If no device is connected, set to AV-30.</p> <p>NAVCOMM is used to connect a serial VOR/ILS using the SL30 protocol. Only one port may be setup as a NAVCOMM.</p> <p>NMEA 4800 and NMEA 9600 are used when connecting a portable GPS</p>

		to the AV-HSI. This provides VFR-only guidance.
SERIAL 3	AV-30, NAVCOMM, NMEA 4800, NMEA 9600	<p>The device type connected to SERIAL 2.</p> <p>If no device is connected, set to AV-30.</p> <p>NAVCOMM is used to connect a serial VOR/ILS using the SL30 protocol. Only one port may be setup as a NAVCOMM.</p> <p>NMEA 4800 and NMEA 9600 are used when connecting a portable GPS to the AV-HSI. This provides VFR-only guidance.</p>
SERIAL 4	AV-30, AV-LINK, AVL+AV30	<p>The device type connected to SERIAL 4.</p> <p>If no device is connected, set to AV-30.</p> <p>AV-LINK is used when an AV-Link is connected directly to the AV-HSI.</p> <p>AVL+AV30 is used when an AV-LINK is connected directly to the AV-HSI and there's also an AV-30</p>

		<p>connected to the AV-HSI harness using Pins 8 and 15.</p> <p>See the AV-Link section of this document for details on connecting the AV-Link directly to an AV-HSI.</p>
429 RX1 SPEED	HIGH, LOW	<p>The ARINC 429 Speed on RX Port 1.</p> <p>Use LOW unless the connected device requires HIGH.</p> <p>This setting MUST match the speed configured in the connected navigator.</p>
429 RX1 SDI	0 COMMON, 1 PILOT, 2 COPILOT	<p>The ARINC 429 Source Destination Identifier.</p> <p>Use 0 COMMON.</p>
429 RX2 SPEED	HIGH, LOW	<p>The ARINC 429 Speed on RX Port 2.</p> <p>Use LOW unless the connected device requires HIGH.</p> <p>This setting MUST match the speed configured in the connected navigator.</p>

429 RX2 SDI	0 COMMON, 1 PILOT, 2 COPILOT	The ARINC 429 Source Destination Identifier. Use 0 COMMON.
429 TX SPEED	HIGH, LOW	The ARINC 429 Speed on the TX Port. Use LOW unless the connected device requires HIGH. This setting MUST match the speed configured in the connected navigator.
429 TX SDI	0 COMMON, 1 PILOT, 2 COPILOT	The ARINC 429 Source Destination Identifier. Use 0 COMMON.
DIGITAL AP	NONE, TYPE 1, TYPE 2	See Autopilot section for details.

Table 20 – AV-HSI Configuration Options

Navigator-specific configuration recommendations are as follows. Refer to the installation manual for your navigator for details:

Avidyne IFD 410/440/510/540/545 Garmin GPS-400(W), GPS-500(W), GNC-420(W), GNS-430(W), GNS-530(W)	
Option	Recommended Setting
Main ARINC 429 Config Page	
In 1 Speed	Low
IN 1 Data	EFIS/Airdata
Out Speed	Low
Out Data	GAMA 429 Graphics w/Int
SDI	Common
VNAV	Enable Labels
VOR/LOC/GS ARINC 429 Config Page	
* Not applicable for IFD510/545/410	
* Not Applicable for GPS-400(W), GPS-500(W), GNC-420(W)	
Speed RX	Low
Speed TX	Low
Format RX	Off
Format TX	VHF/GPS 429
SDI	Common

Table 21 – Avidyne IFD 410/440/510/540/545, Garmin GPS-400(W)/500(W), GNC-420(W), GNS-430(W)/530(W) Configuration

Garmin GPS-155XL, GNC-300XL	
Option	Recommended Setting
ARINC 429 CHANNEL	
Input	Course/Heading
Output	King EFS 40/50
Note: The GPS-155XL and GNC-300XL output basic straight-line flight plans. DME arcs and holding patterns are not sent to the AV-30 for display.	

Table 22 – Garmin GPS-155XL, GNC-300XL Configuration

Apollo CX80, Garmin GNS-480	
Option	Recommended Setting
ARINC 429 SETUP	
CH IN 2 SEL	EFIS
CH IN 2 SPEED	LOW
CH IN 2 SDI	ALL
CH OUT 1 SEL	GAMA 429 NO FP
CH OUT 1 SPEED	LOW
CH OUT 1 SDI	ALL
CH OUT 1 SEL	VOR/ILS
CH OUT 1 SPEED	LOW
CH OUT 1 SDI	ALL
Note: The CX80/GNS-480 outputs basic straight-line flight plans. DME arcs and holding patterns are not sent to the AV-30 for display	

Table 23 – Apollo CX80, Garmin GNS-480 Configuration

Garmin GTN-625(xi), GTN-635(xi), GTN-650(xi), GTN-725(xi), GTN-750(xi)	
Option	Recommended Setting
ARINC 429 Configuration	
ARINC 429 IN 1 SPEED	Low
ARINC 429 IN 1 DATA	EFIS Format 2
ARINC 429 OUT 1 SPEED	Low
ARINC 429 OUT 1 DATA	GAMA Format 3
SDI	Common
VOR/LOC/GS Configuration	
* GTN-650(xi), GTN-750(xi) Only	
Nav Radio	Enabled
ARINC 429 Configuration TX Speed	Low
ARINC 429 Configuration SDI	Common

Table 24 – Garmin GTN-625(xi), GTN-635(xi), GTN-650(xi), GTN-725(xi), GTN-750(xi) Configuration

Garmin GPS-175, GNC-355, GNX-375	
Option	Recommended Setting
ARINC 429	
ARINC RX Port 1 Format	EFIS/ADC (Air Data)
ARINC RX Port 1 Speed	Low
ARINC TX Port 1 Format	GAMA Format 3
ARINC TX Port 1 Speed	Low
SDI	Common

Table 25 – Garmin GPS-175, GNC-355, GNX-375 Configuration

Garmin GNC-215	
Option	Recommended Setting
Interfaces -> RS-232	
Format	NMEA 1

Table 26 – Garmin GNC-215 Configuration

Garmin GNC-255	
Option	Recommended Setting
Serial Port	
IO MODE	NMEA
<p>Notes and Considerations:</p> <p>1. The GNC-255 OBS is controlled by the AV-30 when IO MODE is configured as NMEA. If IO MODE is set to NONE, the GNC-255 still outputs deviation data, but the OBS on the GNC-255 and on the AV-30 operate independently.</p> <p>2. The GNC-255 has only one RS-232 serial port. Some installations may have this sole port connected to a GPS provide the GNC-255 position data for frequency look-up. If using this configuration, ARINC-429 may be used to interface the GNC-255 to the Av-HSI. Connect the GNC-255 ARINC output to AV-HSI ARINC RX2. Configure the GNC-255 ARINC 429 TX to LO SPEED and the SDI to COMMON</p>	

Table 27 – Garmin GNC-255 Configuration

Apollo/Garmin SL-30	
Option	Recommended Setting
Indicator Head Type	SERIAL
<p>Notes and Considerations:</p> <p>The SL-30 OBS is controlled by the AV-30 when Indicator Head Type is configured as SERIAL. If the Indicator Head Type is set to NONE, the SL-30 still outputs deviation data, but the OBS on the SL-30 and on the AV-30 operate independently.</p>	

Table 28 – Apollo/Garmin SL-30 Configuration

Trig TX56(a)/TX57(a)	
Option	Recommended Setting
CDI Type	SERIAL

Table 29 – Trig TX56(a)/TX57(a) Configuration

MGL N16	
Option	Recommended Setting
Head Setup Menu Emulation	SL30
Note: The N16 requires a standalone Razor or Vega control head. The AV-HSI connects to the control head, not directly to the N16.	

Table 30 – MGL N16 Configuration

VAL NAV 2000	
Option	Recommended Setting
Resolver Input Selection (Rs I)	Ser
Serial Mode (SrMd)	Dir

Table 31 – VAL NAV 2000 Configuration

In addition to interfacing with a GPS and a VHF navigation source, the AV-HSI synchronizes data between all connected AV-30s. The synchronization of each field is individually controllable through the State Sync Menu in the AV-30 Installation Menu.



Within this menu select the SOURCE as AV-HSI.



The following fields may be synchronized using the AV-HSI:

Field	Description
Heading Bug	When enabled, changes to the heading bug on one AV-30 updates all other enabled AV-30.
Omni-Bearing Selector	When enabled, changes to the OBS on one AV-30 updates all other enabled AV-30.
Set Altitude	The Set Altitude, also displayed as SALT, is an altitude target used by the autopilot.
Set Vertical Speed	The Set Vertical Speed, also displayed as SVS, is the vertical speed target used by the autopilot. Note that ARINC 429 based autopilots do not use this field from the AV-30.
Autopilot Mode	When enabled, changes to the autopilot mode on one AV-30 updates all other enabled AV-30s.
CDI Source	The navigation source, GPS or VLOC. Having this feature enabled changes the source on all connected AV-30s.

	If it is desired to have AV-30s operate independently, example have one display VLOC and one display GPS, disable this synchronization.
Barometric Pressure	When enabled, changes to the baro setting on one AV-30 updates all other enabled AV-30s.
Outside Air Temperature	When enabled, data from one OAT probe connected to an AV-30 is shared with all other AV-30s.
Directional Gyro Setting	When the pilot sets the DG, that setting is synced to all AV-30s. For installations with the AV-MAG, this should be disabled.
Alerts	The AV-HSI continuously compares the attitude solution generated by every connected AV-30 and will alert if they differ by more than 5 degrees of pitch or roll. This alert can be disabled with this setting.

10.5.8 AV-HSI Ground Checkout

Before flight with the AV-HSI, perform the following steps:

1. Ensure all connected AV-30s are receiving data from the GPS navigator by putting the navigator into self-test mode. Observe lateral and vertical course deviations match expected values of the GPS self-test. Most GPS navigators enter self-test on boot-up. Refer to your GPS manual for details. This verifies the ARINC 429 receive path from the GPS.
2. If your GPS self-test mode displays OBS, observe the OBS being sent by the AV-30. Change the AV-30 OBS and observe the value being reflected on the GPS self-test screen. If your GPS self-test

- mode does not display OBS, verify the OBS is being received by the GPS by setting up OBS or Hold mode. This verifies the ARINC 429 transmit path to the GPS.
3. Tune to a VOR, VOT, or ILS if available at your airport and set the AV-30 NAV SRC to VLOC. Ensure all connected AV-30s are receiving VHF NAV information. If no VHF NAV source is available at your airport, use a navigation signal generator like a Sun Avionics AV-17, Aeroflex IFR-4000, or Viavi AVX-10k. This verifies the VHF NAV receive path from your navigator.
 4. Complete ground checkout procedures as required by your navigation source installation manuals.

10.5.9 AV-HSI Flight Checkout

Before flight into actual IMC conditions, a flight test should be performed verifying the performance of the AV-30, AV-HSI, and your navigator by flying each of the approach types supported by your installation in VFR conditions.

This serves to verify the installation and the pilot's ability to use the equipment. Consider flying with a CFI familiar with AV-30 operations before solo flight in IMC conditions.

10.6 Electronic Flight Instrument System (EFIS)

10.6.1 EFIS Overview

If the AV-30 is used as a backup instrument to a third party EFIS, the EFIS can be connected to the system serial port (Serial 3) by connecting AV-30 Pins 8 and 15.

When connected, user changes made on the EFIS are synchronized with the AV-30 and vice versa.

The following user variables can be synchronized:

- Heading Bug

- Omni-Bearing Selector (OBS)
- Set Altitude (Autopilot Altitude Target)
- Set Vertical Speed (Autopilot Vertical Speed Target)
- Autopilot Mode
- Course Deviation Indicator (CDI) Source (GPS OR VLOC)
- Baro/Altimeter Setting
- Outside Air Temperature (OAT)
- Directional Gyro (DG)

Synchronization of each item is configurable in the installation menu under the state sync menu.



Figure 43 – State Sync Menu

NOTICE

At the time of publishing this Installation Manual, no third party EFIS supports this interface. Contact Technical Support or your EFIS manufacturer to discuss adding this capability.

11 Setup & Configuration

11.1 Startup and Common Controls

When powered on, the initial splash screen presents the company logo, unit model number, and the currently installed software version.



Figure 44 – Splash Screen

Operation in both AI and DG modes share common user interface controls as follows:



Figure 45 – Common User Interface Components

11.2 Available Menus

Setup and configuration menus are divided into three categories as follows:

- Edit Fields Menu (Pilot accessible)
- Setup Menu (Pilot accessible)
- Install Menu (Non-Pilot accessible)

The edit fields menu allows the pilot to configure the display to show the various supplemental parameters in the desired locations. Details of this are covered in *UAV-1004233-001, AV-30-E Pilot's Guide* and not addressed here.

The Setup Menu allows the pilot to set various configurations and alerting limits as desired for the type of operations being performed. These are also covered in the Pilot's Guide referenced above.

The installer may wish to pre-configure some or all these settings for the pilot, but the default settings are acceptable.

NOTICE

The install menu is for settings that are not normally required to be adjusted during flight. The installer must review and set these according to the installation configuration.

12 Installation Menu

The installation menu is used to configure the AV-30 after installation and should only be accessed on the ground and changed by the installer. Setting Angle of Attack limits and calibrating the internal magnetometer are exceptions to this rule.

To enable access the installation menu, ensure the unit is completely turned off. Push and hold the main control knob in while power is applied.



Figure 46 – Installation Menu Access

Keep the knob pressed until the startup logo has cleared. The installation menu will now be enabled for access but will not automatically appear on the screen.

Ensure the unit is in AI or DG mode; select the mode by pushing and holding the center button until the mode display changes. When in AI or DG mode, press and release the left MENU button three times until “INSTALL /

ROT TO SEL” appears. The sequence of fields displayed is shown in Figure 47.



Figure 47 – Installation Menu Access

Rotating the knob left and right will access the various parameters that may be configured. Pressing the knob when the desired field is shown will allow the associated setting to be adjusted.

After adjustment, pressing the knob again will exit the editing mode but the installation menu will remain active.



Figure 48 – Exiting Edit Mode

Pressing DONE or a lack of user input for 30 seconds will exit the installation menu and return to the primary screen.



Figure 49 – Setup Done / Exit Option

Record configured values on a printed copy of Table 32 and retain in aircraft records.

Label	Description	Possible Values	Configured Value(s)
UNIT FUNCTION	Unit functionality	Set to default mode: AI* or DG	
FUNCTION LOCK	Functionality Lock	If locked, pilot may not change unit function	
AI PAGES	Number of AI pages to make available	1, 2, 3*	
DG PAGES	Number of DG pages to make available	1, 2, 3*	
MFD PAGES	Number of MFD pages to make available	DISABLED, 1*	
CDI Pages	Number of CDI pages to make available	DISABLED, 1, 2*	
PITCH TRIM	Pitch trim	Trim as needed: ± 27 Degrees (0*)	
ROLL TRIM	Roll trim	Trim as needed: ± 5 Degrees (0*)	
SLIP TRIM	Slip trim	Trim as needed: ± 5 Degrees (0*)	
OAT TRIM	OAT probe trim	Trim as needed: ± 200 (Unitless) (0*)	
SPD ASST	Use airspeed to enhance attitude calculation	Yes* (on) or No (off)	
IAS TRIM LO	IAS trim at low speed	Trim as needed: ± 100 (in IAS UNITS) (0*)	
IAS TRIM HI	IAS trim at high speed	Trim as needed: ± 100 (in IAS UNITS) (0*)	
ALT TRIM LO	Barometric altitude trim	Trim as needed: ± 500 Feet	
ALT TRIM HI	Barometric altitude trim at value > 10,000' from ALT TRIM LO	Trim as needed: ± 500 Feet	
PITOT ZERO	Pressure sensor age compensation	Automatically determined by measurement	
AOA FUNC	Angle of Attack Alert	ENABLED*, DISABLED	
IAS UNITS	IAS display units (also affects groundspeed and V-speed settings units)	Knots* (KTS), Miles Per Hour (MPH), or Kilometers Per Hour (KPH)	

TAS UNITS	TAS display units	Knots* (KTS), Miles Per Hour (MPH), or Kilometers Per Hour (KPH)	
IAS VSO	Stalling speed in landing configuration	Set to match limits: 40 to 555 (50*) in IAS UNITS	
IAS VS1	Stalling speed in a specific configuration	Set to match limits: 40 to 555 (60*) in IAS UNITS	
IAS VFE	Maximum flap extended speed	Set to match limits: 40 to 555 (100*) in IAS UNITS	
IAS VNO	Maximum structural cruising speed	Set to match limits: 40 to 555 (150*) in IAS UNITS	
IAS VNE	Never exceed speed	Set to match limits: 40 to 555 (175*) in IAS UNITS	
IAS VMC	Minimum control airspeed with the critical engine inoperative	Set to match limits: 40 to 555 or disabled* in IAS UNITS	
IAS VYSE	Speed for best rate of climb OEI (single engine)	Set to match limits: 40 to 555 or disabled* in IAS UNITS	
BARO UNITS	Altimeter barometric units	Inches of Mercury* (INHG), Millibars (MB), hectopascals (HPA)	
TEMP UNITS	OAT units	Celsius* (C) or Fahrenheit (F)	
GPS NAV SRC	Serial GPS format	NONE, SERIAL 1*, SERIAL 2	
SERIAL 1	GPS serial input	NONE, AV 9600*, NMEA 4800, NMEA 9600, BCNX GPS, AV-HSI	
SERIAL 2	Auxiliary serial input	NONE*, BEACON X, AV-APA, AEROCRUZE, PRO PILOT	
SERIAL 3	System serial input	NONE, AVLINK*, EFIS, EFIS+AVLINK	
SERIAL 4	AV-Mag serial input	NONE*, AVMAG	
AVHSI CFG	AV-HSI Configuration	See Table 34 – AV-HSI Submenu	Record setting in
STATE SYNC	Synchronization of pilot settings across multiple AV-30s using AV-HSI or between an AV-30 and EFIS.	Source: None, AV-HSI*, EFIS Heading Bug: No, Yes* OBS: No, Yes* Set Altitude: No, Yes* Set Vertical Speed: No, Yes* Autopilot Mode: No, Yes*	

		CDI Source: No, Yes* Baro Setting: No, Yes* OAT: No, Yes* DG: No, Yes* Alerts: No, Yes*	
AID MODE	AHRS aiding mode	NONE ^[1] , MAG1*, MAG2, AVMAG ^[2]	
AVMAG INSTL	AV-Mag Installation	See Table 33 – AV-Mag Submenu for submenu description	Record settings in Table 33
AVMAG CAL	Calibrates external magnetometer	Perform calibration after installation – only available for units with external magnetometer	
AVMAG YAW	AV-Mag installed Yaw angle trim	Trim as needed: ±15 Degrees (0*)	
MAG MONITOR	Magnetometer monitor	Push to view	
VIBE MONITOR	Vibration monitor	Push to view	
GYRO CAL	Calibrates aircraft gyros	Perform at installation or software update	
INT MAG CAL	Calibrates internal magnetometer	Perform calibration after installation – only available for units with internal magnetometer. Disabled when external magnetometer installed.	
AV-APA CFG	Specify the autopilot connected to the AV-APA	NONE, S-TEC	
AV-APA THRU	Specify the device connected to the AV-APA passthrough port	NONE, BEACON X	
GPSS GAIN	Increase/decrease GPSS signal level from AV-APA. Increase if autopilot joins course too slowly, decrease if autopilot overshoots course.	0.5 to 3.0	
ADVANCED AP	See 10.4.4		
DEMO MODE	Demo mode	DISABLED*, MODE 1, MODE 2	
RESET AVLINK	Factory reset operation on attached AV-Link	Push to execute	
BEACONX GTM	BeaconX ground test mode	Push to execute	
SW PART NUM	Software part number	For reference	
SW VERSION	Software version	For reference	
SW CHECKSUM	Software checksum	For reference	

BL VERSION	Bootloader version	For reference	
AVMAG SW PN	AV-Mag software part number	For reference	
AVMAG SW VER	AV-Mag software version	For reference	
AVAPA SW PN	AV-APA software version	For reference	
AVAPA SW VER	AV-APA software part number	For reference	
AVLINK SW PN	AV-LINK software part number	For reference	
AVLINK SW VER	AV-LINK software version	For reference	
AVHSI SW PN	AV-HSI software part number	For reference	
AVHSI SW VER	AV-HSI software version	For reference	
BATTERY	Battery type	For reference	
SW CERT	Software certification	For reference	

Table 32 – Installation Menu Settings

* Initial factory value [1] Initial and only option for units without magnetometer [2] Only valid for AV-Mag

Label	Description	Possible Values	Configured Value(s)
INTERFERENCE	Checklist of systems to exercise and monitor for excessive interference with the AV-Mag	LIGHTS, AVIONICS, CONTROLS, OTHER, ALL ON, REVIEW	
INSTL ORIENT	Orientation of the installed AV-Mag	See Table 11 for more details	
AV-30	Angles of the AV-30 instrument in the stationary aircraft.	No user entry. Information for AV-Mag installation only. AV-Mag should be installed as closely as possible to the AV-30 angles.	
ROLL ANGLE	Roll angle of the AV-Mag as mounted in the stationary aircraft	Trim as needed: ± 10 degrees (0.0*) – May be automatically self-measured by AV-Mag hardware	
PITCH ANGLE	Pitch angle of the AV-Mag as mounted in the stationary aircraft	Trim as needed: ± 10 degrees (0.0*) – May be automatically self-measured by AV-Mag hardware	
SAVE (Y/N)	Option to save changes to input roll and pitch angles	YES, Y/N?, NO. Only save when installing and a valid hand measurement of the angles AS THE AIRCRAFT SITS. Do not 're-save' the values when reviewing as this will trigger re-calculations that will be invalid if the aircraft has been moved since the hand measurement.	
COMPLETE	Final screen of installation submenu. The next step of installation is to run the calibration procedure.	Information only	

Table 33 – AV-Mag Submenu

* Initial factory value

Label	Description	Possible Values	Configured Value(s)
SERIAL 2	Device connected to AV-HSI Serial 2	AV-30*, NAVCOMM, NMEA 4800, NMEA 9600	
SERIAL 3	Device connected to AV-HSI Serial 3	AV-30*, NAVCOMM, NMEA 4800, NMEA 9600	
SERIAL 4	Device connected to AV-HSI Serial 4	AV-30*, AVLINK, AVL+AV30	
429 RX1 SPEED	Bus speed of RX 1	HIGH, LOW*	
429 RX1 SDI	Source/Destination Indicator (SDI) of RX 1	0 COMMON*, 1 PILOT, 2 COPILOT	
429 RX2 SPEED	Bus speed of RX 2	HIGH, LOW*	
429 RX2 SDI	SDI of RX 2	0 COMMON*, 1 PILOT, 2 COPILOT	
429 TX SPEED	Bus speed of TX	HIGH, LOW*	
429 TX SDI	SDI of TX	0 COMMON*, 1 PILOT, 2 COPILOT	
DIGITAL AP	The type of ARINC 429 autopilot connected to AV-HSI	NONE*, TYPE 1, TYPE 2	

Table 34 – AV-HSI Submenu

* Initial factory value

12.1 Mandatory Settings

The following settings are mandatory for each installation.

12.1.1 Unit Function

- Set to AI if installation is replacing an existing Attitude Indicator.
- Set to DG if installation is replacing an existing Direction Indicator.
- Set to either when installed as a non-required instrument. In this mode, this setting is the initial default operating mode if the function lock below is not set to locked. With this setting, the pilot may toggle the mode during flight.

12.1.2 Function Lock

Enable function lock for primary AI and DG installations. This prevents the pilot from toggling the operating mode.

Installation as a non-required instrument may be locked or not locked, based on owner preferences. Pressing and holding the center knob when functionality is not locked will toggle between AI, DG, and MFD modes.

12.1.3 Trim

Set Pitch, Roll and Slip Trim to accommodate any mounting variations. Accurate pitch, roll and slip trim is important to ensure optimal performance

Set IAS and Altitude Trims to adjust the AV-30 to match a calibrated pitot static test set as needed. Trim the OAT values to match that of a secondary calibrated temperature source.

12.1.4 Speed Assist

Use airspeed to improve attitude accuracy.

This setting should be set to Yes (enabled) unless this installation cannot meet required pitot-static connections and performance.

12.1.5 Angle of Attack

Angle of Attack alerts are enabled by default but may be disabled if desired.

12.1.6 V-Speeds

Set each of the V-Speeds to the values that correspond to the installation aircraft, in the units selected in §12.1.7.

12.1.7 Display Units

Set the IAS units to match that of the existing airspeed indicator. IAS and GPS ground speed are displayed in these units, and the IAS TRIM and IAS V-speed settings will be applied in the selected units.

Set the TAS units to owner / pilot preference.

Set the Baro units to match that of the existing altimeter.

Set OAT units to owner / pilot preference.

12.1.8 Serial Inputs

GPS NAV SRC

Multiple serial ports support GPS sources. Set to the serial port on which your GPS source is installed.

Value	GPS Source
NONE	None available
SERIAL 1	Specified in SERIAL 1 setting
SERIAL 2	Specified in SERIAL 2 setting

SERIAL 1

This serial port corresponds to DB-15 pin 2 and 3. Set according to the type of the installed GPS navigator on this port.

Most handheld GPS navigators produce output in NMEA format while most panel-mounted navigators produce Aviation format.

A tailBeaconX can also supply GPS data. To use it as a GPS source when BCNX GPS is selected, the tailBeaconX must share its serial connection with a second AV-30. The second AV-30 must have SERIAL 2 set to BEACON X. See Figure 23 – Parallel tailBeaconX GPS Connections for a diagram of the required connections and settings in this configuration.

Value	Serial 1 Source
NONE	None available
AV 9600	Aviation format (9600 bps)
NMEA 4800	NMEA format (4800 bps)
NMEA 9600	NMEA format (9600 bps)

BCNX GPS	tailBeaconX is installed (see Figure 23)
AV-HSI	When AV-HSI is connected

SERIAL 2

This serial port corresponds to DB-15 pins 4 and 5. This serial port supports a tailBeaconX or autopilot connection.

If using the AV-30 as a control head for a tailBeaconX, set SERIAL 2 to BEACON X. Otherwise, set SERIAL 2 according to the autopilot connection (or NONE if nothing is connected).

Value	Serial 2 Source
NONE	None available
BEACON X	tailBeaconX is installed on SERIAL 2
AV-APA	AV-APA is installed on SERIAL 2
AEROCRUZE	AeroCruze 100/ xCruze 100 /TruTrak Vizion autopilot
PRO PILOT	Trio Pro Pilot

SERIAL 3

Serial 3 is the system serial port. If using the AV-Link, set SERIAL 3 to AVLINK to enable MFD page. If connecting to a third-party EFIS, set to EFIS. If using an AV-Link and connecting a third-party EFIS, set to EFIS+AVLINK.

Value	Serial 3 Source
NONE	None available
AVLINK	AV-Link is installed, MFD enabled
EFIS	Third-party EFIS connected

EFIS+AVLINK	An AV-Link is installed and a third-party EFIS is connected, MFD enabled
-------------	--

NOTE: at the time of publishing, multiple EFIS manufacturers are working on integrating with the AV-30, but none have published their updates. Use NONE or AVLINK until EFIS support is included by your third-party EFIS vendor.

SERIAL 4

If using the AV-Mag, set SERIAL 4 to AVMAG to enable the external magnetometer aiding.

Value	Serial 4 Source
NONE	None available
AVMAG	AV-Mag is installed

12.1.9 AID Mode (Magnetometer)

There are up to 3 options for the AID MODE, which controls the method of aiding the AHRS DG functionality.

Value	AHRS Aiding Source
NONE	None used
MAG1	Internal magnetometer provides correction data to DG.
MAG2	Internal magnetometer provides correction data to DG and aiding to core AHRS algorithm
AVMAG	External magnetometer provides continuous heading data to DG and aiding to core AHRS algorithm. AV-Mag only.

Rotate the center knob until “AID MODE” is displayed. If the internal magnetometer is available (P/N UAV-1004035-002) then you will have a choice of NONE, MAG1, and MAG2. If the internal magnetometer is not found, only “NONE” will be displayed. If Serial 4 is set to AVMAG, AID MODE will be automatically set to AVMAG and is not otherwise settable.



Figure 50 – AID Mode Selection

Push the center knob and rotate to select your choice of Magnetometer aiding then push the center knob again to confirm your choice.

12.1.10 Demo Mode

Set Demo Mode to DISABLED. Demo Mode will automatically be disabled when reaching an airspeed of 35 knots.

12.2 System Checkout

The following procedures must be performed prior to returning the aircraft to service.

12.2.1 Alignment

During initial startup, the ALIGN annunciator should be presented as a flashing red flag. This indicates internal sensor stabilization is occurring. During the alignment, do not move the aircraft.

This should extinguish within 3 minutes, at which point valid attitude or direction indication is displayed.

If power is removed from the unit while it is still aligning the unit will go to battery mode until it has completed the alignment process.



Figure 51 – Aligning Annunciator

If the indicator is not extinguished within 3 minutes, reference §13 of this document for troubleshooting information.

12.2.2 Gyro Calibration

As units age or experience unusual conditions, the precision gyroscopic sensors may need to be re-calibrated. This can be accomplished in the field using the procedure noted here. At least 10 minutes of warmup is required before performing the AV-30 gyro calibration.

1. Before applying power, push and hold the center rotary knob and apply power. As the splash screen appears, check that a minimum version of 2.1.1 is displayed. Gyro Calibration must be completed on all units with software version 2.1.1 or later

2. With the AV-30 in the AI mode, enter the “Install menu” page by pressing and releasing the left button repeatedly until the 3rd menu is displayed. The aircraft must be on the ground with no movement.



Figure 52 – Install Mode Selection

3. It is critical to ensure the aircraft is completely motionless and on the ground during the next several steps. The aircraft should be in a hangar and must not be affected by wind or other sources of aircraft movement. Do not leave the aircraft during the countdown.
4. Enter the “Install Menu” again. Rotate to Gyro Cal and push the center button to choose calibration. If sufficient warmup time has not elapsed, a “Not ready to calibrate” message and countdown will be indicated. Otherwise, initiate calibration by pressing the right button.



Figure 53 – Gyro Calibration Selection

5. “Calibration in progress” will be displayed with a completion percentage.
6. A success screen will be presented upon successful calibration. Push the left button under “DONE” and the calibration will be complete. If an error is shown, repeat the calibration process.



Figure 54 – Gyro Calibration Procedure

If any post-accomplishment check fails, please contact uAvionix support.

12.2.3 In-Flight Internal Magnetometer Calibration

Units with an internal magnetometer (P/N UAV-1004035-002) require an in-flight magnetic calibration procedure to be performed. When calibration needs to be performed, in the absence of other flags, a red flag (MAG CAL) will appear.



Figure 55 – MAG CAL Flag and INT MAG CAL Selection

1. The internal magnetometer calibration feature is found in the install menu. Hold down the center button while applying power. The installation menu can now be accessed until the next power cycle.
2. Once established in flight, select INT MAG CAL, then press CALIB. Note that INT MAG CAL will be disabled on units without an internal magnetometer, or when an external magnetometer is installed.



Figure 56 – INT MAG CAL Entry and Progress

3. Fly for 10 minutes. Four 360-degree, standard-rate turns will need to be completed. Each turn will represent 25% of the total.

- Click the left button under “Done” when completed. Once complete, the red flag will extinguish. If the calibration failed, please complete again.



Figure 57 – INT MAG CAL Success and Failure Screens

The AV-30 will retain all calibration even if a hard reset is executed. Internal magnetometer and external magnetometer calibration data are stored independently.

12.2.4 AV-Mag Calibration Check

With the aircraft engine running, lights on, and pitot heater on, orient the aircraft at each heading below and record the heading reported by the AV-30. Turn on the HDG textual overlay to obtain a precise value. Note: constant error of up to 3 degrees can be corrected using the AV-MAG YAW option in the Installation Menu. If experiencing larger error, adjust your AV-MAG installation to align with forward flight and re-calibrate.

Parameter	Value
Installation Location on Aircraft	
AV-Mag Orientation	
Interference Range	
Max Interferer	
Min Interferer	
AV-30 Roll Angle	
AV-30 Pitch Angle	
AV-Mag Roll Angle	
AV-Mag Pitch Angle	
AV-Mag Yaw Angle (post-calibration)	

Table 35 – AV-Mag Installation Parameters

Magnetic Heading	AV-30+AV-Mag Reported Heading	Magnetic Heading	AV-30+AV-Mag Reported Heading
0		180	
30		210	
60		240	
90		270	
120		300	
150		330	

Table 36 – Calibrated Heading Check

12.2.5 OAT Interface

If an Outside Air Temperature (OAT) probe is connected, utilize the display customization guidance provided in the Pilots Guide to configure the display to show OAT in at least one textual display field.



Figure 58 – OAT Indicator

Note that OAT calibration is performed in the Setup procedures. This step only ensures that the OAT probe is detected properly.

12.2.6 GPS Navigator Interface

If a GPS Navigator is connected, utilize the display customization guidance provided in the Pilot's Guide to configure the display to show GPS navigational data in at least one textual display field.

The image below shows a typical configuration that the pilot may setup.



Figure 59 – GPS Data Elements

On the GPS navigator, set a destination waypoint and initiate a direct-to sequence. Note that not all navigators will output serial data until a waypoint has been selected and navigation initiated.

12.2.7 Vibration Check

Prior to flight, a vibration check **must** be completed. The vibration check helps ensure the vibration characteristics of the aircraft and installation are suitable for use. The check procedure is performed during an engine run-up.

1. Before applying power to the AV-30, press and hold the center rotary knob and apply power. As the splash screen appears, check that a minimum version of 2.1.1 is displayed.
2. Enter the “Install Menu” page by pressing and releasing the left button repeatedly until the 3rd menu is displayed.
3. Rotate to “VIBE MONITOR” and press the center button.



Figure 60 – Vibe Monitor Selection

4. The Vibration Monitor will display current and peak values for the Accelerometer and Gyroscope.



Figure 61 – Vibe Monitor Operation

5. Perform an engine run-up, slowly increase engine power from idle to full and back to idle.
6. Record the peak values observed for both the Accelerometer and Gyroscope.

Peak values for the Accelerometer should not exceed **110**, and for the Gyroscope should not exceed **40**. If excessive values are observed, vibration must be mitigated to ensure expected performance. Consider the following:

- Ensure proper propeller balance. Perform dynamic propeller balancing.
- Replace worn engine mounts and address causes of high engine vibration.
- Ensure the AV-30 is not mounted in a location subject to high vibration. This can often be detected by placing your hand on various locations in the panel, and can be caused by poorly supported panel regions, adjacent equipment, or proximity to engine structure.
- On isolated panels, replace the grommets; concurrently, ensure isolated panels have a ground strap.

- Ensure all mounting hardware is firmly attached.
- Check for rub marks on the AV-30 case.

Ensure connectors are firmly attached, and all cabling is firmly supported and not causing undue flex. The cabling must not be hitting or close to a moving surface (e.g., control yoke).

12.2.8 Air Data – Pitot-Static Zero

As the AV-30 ages or is exposed to unusual conditions, the pressure sensors may age and require field adjustment to maintain accuracy. If the Indicated Airspeed (IAS) appears to be inaccurate, the Pitot and Static pressure sensors may have aged unevenly and yielding inaccurate readings. This may be remedied by executing the PITOT ZERO function in the installation menu.



The PITOT ZERO function measures both the pitot and the static pressure sensor with identical air pressure conditions. Any difference in reading is saved and applied to subsequent airspeed calculations.

To execute the PITOT ZERO function, go to the AI mode screen, go to the AV-30 installation menu and select PITOT ZERO. Your PITOT tube must be uncovered and the aircraft must be in a still air environment. Press and release the right button. If the measurement was successful a message stating “Measurement Complete P-S Difference 0.x” will appear. Press and release the left button or the center knob to exit. If the measurement failed, a message stating “Measurement Failed” will appear. Check the measurement conditions and try again. If the function still fails, please contact product support.

12.2.9 Air Data – Altitude Trim

As the AV-30 ages or is exposed to unusual conditions, the pressure sensors may require field adjustment to maintain accuracy. If the Altitude appears to be accurate at some altitudes and increasingly inaccurate as you increase or decrease altitude, a trim adjustment may be beneficial. This function requires a calibrated air data test set connected to the AV-30 to simulate multiple altitudes.

To execute this function, go to the AI mode page on the AV-30 and set the barometric pressure to 29.92. Now go to the installation menu and select ALT TRIM LO. Set the air data test set at a low altitude point somewhere between -1,000’ and 14,900’. Press and release the center knob then turn the knob until the value displayed for BaroCorrAlt + Trim: is equal to the altitude on the air data test set. Press and release the center knob to exit the menu.





Now increase the altitude on the air data test set to a value at least 10,000' feet higher than the low altitude. Go to the ALT TRIM HI menu item. If the AV-30 perceives the altitude difference to be less than 10,000', ALT TRIM HI will be grayed out and un-selectable. If that is the case, keep increasing the altitude until ALT TRIM HI turns from gray to white. Press and release the center knob then turn the knob until the value displayed for BaroCorrAlt + Trim: is equal to the altitude on the air data test set. Press and release the center knob to exit the menu.

Record the ALT TRIM LO and ALT TRIM HI values in the aircraft records.

12.2.10 Air Data – IAS Trim

As the AV-30 ages or is exposed to unusual conditions, the pressure sensors may require field adjustment to maintain accuracy. If the indicated air speed appears to be accurate at some airspeeds and increasingly inaccurate as airspeed increases or decreases, a trim adjustment may be beneficial. This function requires a calibrated air data test set connected to the AV-30 to simulate multiple airspeeds.

To execute this function, select the AI Mode on the AV-30. Go to the installation menu and select IAS TRIM LO. Set the air data test set to 45 knots or V_{SO} of your aircraft, whichever is greater. Press and release the center knob then turn the knob until the airspeed displayed on the AV-30

is equal to the airspeed indicated on the test set. Press and release the center knob to set.



Now increase the airspeed on the air data test set to a value at least 70 knots higher than the airspeed used to set the LO trim point. Using your aircraft's high-speed cruise airspeed is recommended. Go to the IAS TRIM HI menu item. If the AV-30 perceives the airspeed difference to be less than 70 knots more than the speed used to set the LO trim, IAS TRIM HI will be grayed out and un-selectable. If that is the case, keep increasing the IAS on the test set until IAS TRIM HI turns from gray to white. Press and release the center knob then turn the knob until the IAS displayed is equal to the IAS on the air data test set. Press and release the center knob to exit the menu.

Record the IAS TRIM LO and IAS TRIM HI values in the aircraft logbook.

12.2.11 AV-APA Checkout

Power up the AV-30 and AV-APA. Observe that the 'NO AP' flag is displayed. This flag indicates that the AV-APA is not providing valid heading input to the autopilot. If the 'NO AP' flag is present on startup, it is an indication that the AV-APA and AV-30 are not communicating. Check wiring to resolve. The 'NO AP' flag can also indicate that the pilot has selected a mode and the required data isn't available. For example, a pilot selecting a GPS-based mode without a GPS or flight plan loaded.

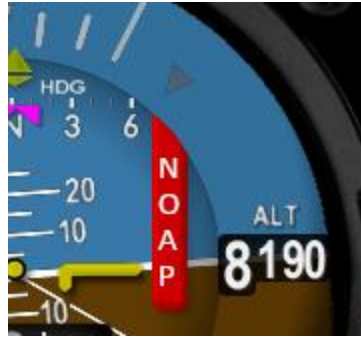

Follow the ground checkout procedure from your autopilot installation manual. In general, this involves setting the autopilot to heading mode and observing that the flight controls move in the correct direction as the heading bug is changed left and right of the current heading.

12.2.12 EMC Checkout

An EMC check should be performed after the AV-30 installation is complete. The EMC check verifies that the newly installed equipment is not producing interference to other avionics and that the existing avionics are not producing interference to the AV-30. The testing assumes the AV-30 operational check has been completed and that the installed avionics to be tested are all in working condition.

1. Power on all avionics except the AV-30.
2. Verify all existing avionics are functioning properly. Some systems may require startup messages to be acknowledged/cleared to verify proper function.
3. After confirming all existing avionics are functioning properly, power off all existing equipment.
4. Power on the AV-30 and perform the following tests as they apply to the existing aircraft equipment.
5. Observe load shedding procedures as appropriate for the aircraft during testing to ensure adequate power to complete the testing

while maintaining enough reserve to support pre-flight and engine start.

VHF COM RADIOS

Verify AV-30 operates without interference from the VHF COM operation.

1. Power on the VHF COM radio.
2. Transmit on a low, medium, and high frequency. Unused frequencies are recommended for this test. Example frequencies: 118.0, 126.0, and 135.0 Mhz.
3. During each transmission verify the AV-30 continues to operate properly.

Verify each radio operates without interference from the AV-30.

1. Monitor a local frequency and verify there are no unintended squelch breaks or other tones that would interfere with communications.
2. Monitor a remote (distant) frequency and verify there are no unintended squelch breaks or other tones that would interfere with communications.
3. Monitor an unused frequency and verify there are no unintended squelch breaks or other tones that would interfere with communications.

VHF NAV RADIOS

Verify VHF NAV operates without interference from the AV-30.

1. Power on the VHF NAV radio.
2. Monitor a local, remote, and unused frequency.
3. Verify there are no misleading navigation indications during the monitoring of each frequency.

4. Verify audible station ID and that the station is clear of audio interference that would prevent identification.

ADDITIONAL AVIONICS

Additional Avionics should be tested according to the manufacturer EMC/EMI test procedures. This testing assumes the existing equipment is functional and operating correctly at time of testing. The following summarizes a typical EMC test.

1. Operate the AV-30.
2. Operate the existing installed avionics according to manufacturer instructions. If capable, utilize the device transmit and receive functions through a range of values.
3. Verify no errors, warnings, or unexpected operation is observed on the AV-30 during operation of the installed avionics.
4. Verify no errors, warnings, or unexpected operation is observed on the installed avionics during operation of the AV-30.

13 Troubleshooting

The following steps are to aid in identifying installation or unit performance related issues:

Issue	Possible Reason
Power	
Unit does not power-on	Check associated breakers
	Ensure aircraft battery is greater than 10 VDC
	Check wiring and pinouts
Unit will not shut off, even if power is removed	Ensure no pitot or static blockage or line kinks are present (locking pressure and airspeed indication over 40 knots)
	Pitot and Static sensors need to be zeroed as described in § 12.2.8
Stabilization	
Unit will not stabilize and aligning annunciator remains on	Return to factory for service if unit does not align within 3 minutes of power-on
DG drifts more than 30 degrees per hour	Ensure running latest available software; perform Vibration Check as described in §12.2.7
	Perform Gyro Calibration as described in §12.2.2
Battery	
Battery indicator shows FAIL	Contact uAvionix support
Trim	
Roll, Pitch or Slip show small but constant error	Ensure unit is level in panel (using a bubble level or similar)
	Set trim adjustment in Installation menu. See 12.1.3 for details.
Airspeed or Altitude shows small but constant error	Set trim adjustment in Installation menu. See 12.1.3 for details.

Interface	
GPS information is expected but does not show up in data overlays	Check GPS input is configured to match the connected GPS serial data type and speed.
	Set direction indication to GPS TRK
"NO DATA" is shown	Check interface cables and pinouts
"NO GPS" is shown	Check GPS input is configured to match the connected GPS serial data type and speed
Splash screen shows "ERROR: Problem with bootloader. Factory service required."	Contact uAvionix support
Splash screen shows "ERROR: PROV value check failure. Service required."	Contact uAvionix support
Splash screen shows "ERROR: F-CAL value check failure. Verify user calibration data."	Check Altitude Trim LO/HI, IAS trim LO/HI, Pitot-zero setting, and magnetometer installation and calibration data. Re-execute any field calibrations that show values not matching records.
Alerts	
Audio alerts not heard over the audio system	Check wiring and ensure alerts are enabled in the Setup menu
	Ensure unswitched input is available on the audio panel
	Verify volume setting is sufficiently high in the Setup menu
Nuisance alerts are generated	Ensure alerting limits are configured as desired in the Setup menu
Nuisance "CHK ATTITUDE" alert when using with the AV-HSI	The AV-HSI continuously compares the attitude solution from all connected AV-30 and will generate an alert if they differ by more than 8 degrees of pitch or 8 degrees of roll. If nuisance alerts are present, perform the Pitot Static Zero and gyro calibration procedures in 12.2.
AV-APA	
"NO AP" flag on screen	"No AP" indicates either: 1) The AV-30 is configured to use an AV-APA but the AV-30 isn't communicating with the AV-APA. Check Wiring. Or 2) the autopilot mode is set to a GPS mode for which data isn't available. E.g. WPT BRG is selected but there is no waypoint in the GPS. Check GPS or change autopilot mode.
Autopilot doesn't respond to heading changes in the AV-30.	In the AV-30 installation menu, ensure AV-APA CFG is set to the autopilot type used. Setting to none causes the AV-APA to output nothing.
AV-HSI	

AVHSI CFG menu stays gray and is not selectable.	The AV-HSI Configuration Menu is only selectable if the AV-HSI and AV-30 are communicating. 1) Ensure that AV-30 SERIAL 1 is set to AV-HSI 2) Check wiring
AV-MAG	
Unit flashes "NO MAG" on right side	Ensure software version 2.4.1 or newer is loaded on the AV-30. If still persistent, check AV-Mag wiring for intermittent connection or poor grounding.
	Check that you have selected the intended internal or AV-Mag external magnetometer function.
Unit flashes "MAG CAL" on the right side	Complete the Mag Calibration flight in § 12.2.3 if using the internal magnetometer. Complete the on-ground 12-point calibration in §12.2.4 if using the external magnetometer.

Table 37 – Troubleshooting

14 Serial Interface Specification

GPS serial input is compatible with the “Aviation” and NMEA serial protocols. Aviation protocol is 9600 Baud, No Parity, 8 Data Bits, 1 Stop bit. NMEA is either 4800 or 9600 Baud, No Parity, 8 Data Bits, 1 Stop Bit. BeaconX UCP is 2400 baud, No Parity, 8 Data Bits, 1 Stop Bit.

The packets received are as follows:

Parameter Name	Aviation Packet	NMEA Packet	BeaconX - UCP Transponder Status (v3)
Lat	“A” Packet	\$GPRMC, Field 4	N/A
Lon	“B” Packet	\$GPRMC, Fields 5,6	N/A
GPS Track	“C” Packet	\$GPRMC, Field 8	Track Heading
GPS Ground Speed	“D” Packet	\$GPRMC, Field 7	Horizontal Velocity
Distance to Waypoint	“E” Packet	\$GPRMB, Field 10	N/A
Cross Track Error	“G” Packet	\$GPRMB, Field 2	N/A
Desired Track	“I” Packet	Computed	N/A
Waypoint ID	“K” Packet	\$GPRMB, Field 5	N/A
Bearing to Waypoint	“L” Packet	\$GPRMB, Field 11	N/A
Magnetic Variation	“Q” Packet	\$GPRMC, Field 10	N/A
Flight Plan	“w” Packet	\$GPRTE, \$GPWPL	N/A

Table 38 – GPS Serial Specification

15 ARINC 429 Interface Specification

When using an AV-HSI, the following ARINC 429 receive messages are processed. Message definitions are per GAMA 429 Specification.

Parameter Name	ARINC 429 Label
Flight Plan Header	Label 74
Active Waypoint To From	Label 75
Selected Course	Label 100
Flight Plan Message Checksum	Label 113
GPS Desired Track	Label 114
GPS Waypoint Bearing	Label 115
GPS Crosstrack	Label 116
GPS Vertical Deviation	Label 117
GPS Horizontal Command	Label 121
GPS Magnetic Variation	Label 147
Localizer Deviation	Label 173
Glideslope Deviation	Label 174
VOR Omnibearing	Label 222
GPS Distance To Go	Label 251
GPS Discrete Word	Label 261
LRN Status Word	Label 275
STN Declination Type Class	Label 300
Waypoint Message Length Type Number	Label 303
Waypoint Message Characters 1 - 3	Label 304
Waypoint Message Characters 4-6	Label 305
Nav Waypoint Airport Latitude	Label 306
Nav Waypoint Airport Longitude	Label 307
Present Position Latitude	Label 310
Present Position Longitude	Label 311
GPS Ground Speed	Label 312
GPS Track	Label 313
DME Arc Radius	Label 325
GPS Lateral Deviation Scale Factor	Label 326
GPS Vertical Deviation Scale Factor	Label 327
Conic Arc Inbound Course	Label 331
Conic Arc Course Change	Label 332
Airport Runway Azimuth	Label 333
Airport Runway Length	Label 334
Left/Right Holding Pattern Azimuth	Label 335
Left/Right Procedure Turn Azimuth	Label 340

Table 39 – ARINC 429 Receive Specification

The following ARINC 429 messages are transmitted by the AV-HSI:

Parameter Name	ARINC 429 Label
Selected Course	Label 100p
Selected Heading	Label 101g
Selected Altitude	Label 102*
Selected Course 2	Label 110
GPS Vertical Deviation	Label 117*
GPS Horizontal Command	Label 121*
Pressure Altitude	Label 203
Baro Corrected Altitude	Label 204
Indicated Airspeed	Label 206
True Airspeed	Label 210
Total Air Temperature	Label 211
Vertical Speed	Label 212
Static Air Temperature	Label 213
Baro In Hg	Label 235
Magnetic Heading	Label 320
* denotes Advanced Autopilot Unlock required	

Table 40 – ARINC 429 Transmit Specification

16 Field Update Capability

The unit software can be field updated. Updating requires either an in-line harness and Windows based PC, or the optional AV-Link accessory to be installed. Contact uAvionix support for additional information, or reference available Service Bulletins.

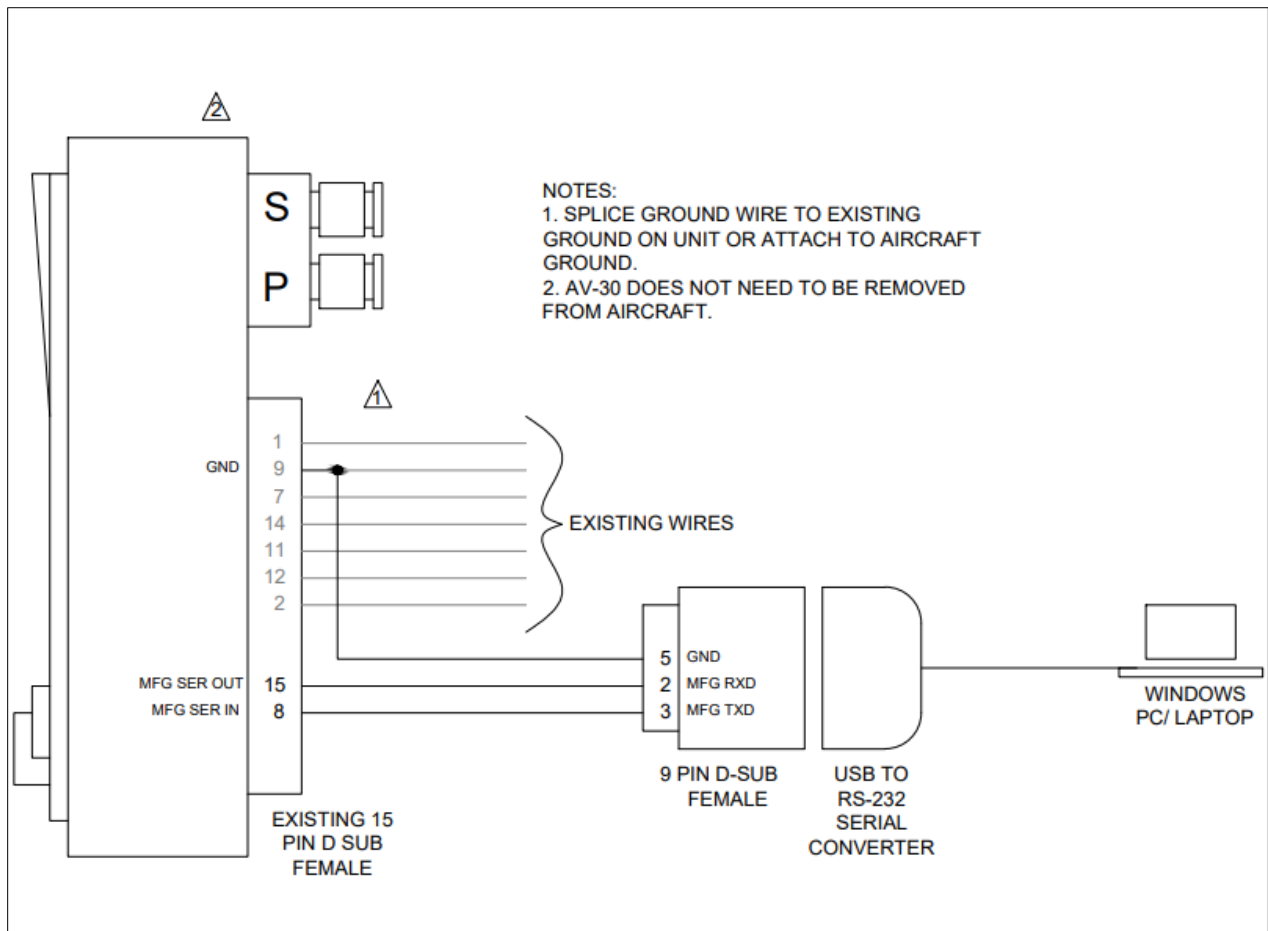

Figure 62 – Field Update Interface Diagram

17 Appendix A: Example Wiring Schematics

Below are a series of example wiring diagrams showing interconnection between a variety of uAvionix and third-party equipment. While these diagrams show common configurations, they do not enumerate all combinations or options. Extrapolation or interpolation between diagrams may be necessary.

Pitot-static connections are not depicted on these diagrams; however, they are necessary on all AV-30.

Configuration

- Single AV-30
- Minimal Install

Install Menu

- Serial 1: NONE
- Serial 2: NONE
- Serial 3: NONE
- Serial 4: NONE

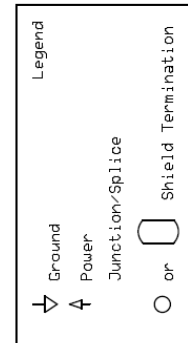
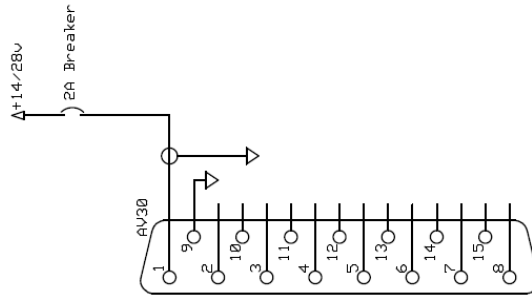

Notes

- Use M27500-22TG114 for Power
- Terminate power shield at AV-30

uAvionix Corporation
Single AV-30 CFG #1

Example Wiring
UAV-1007647-001

Rev. B
10/3/2024

Page 1 of 1

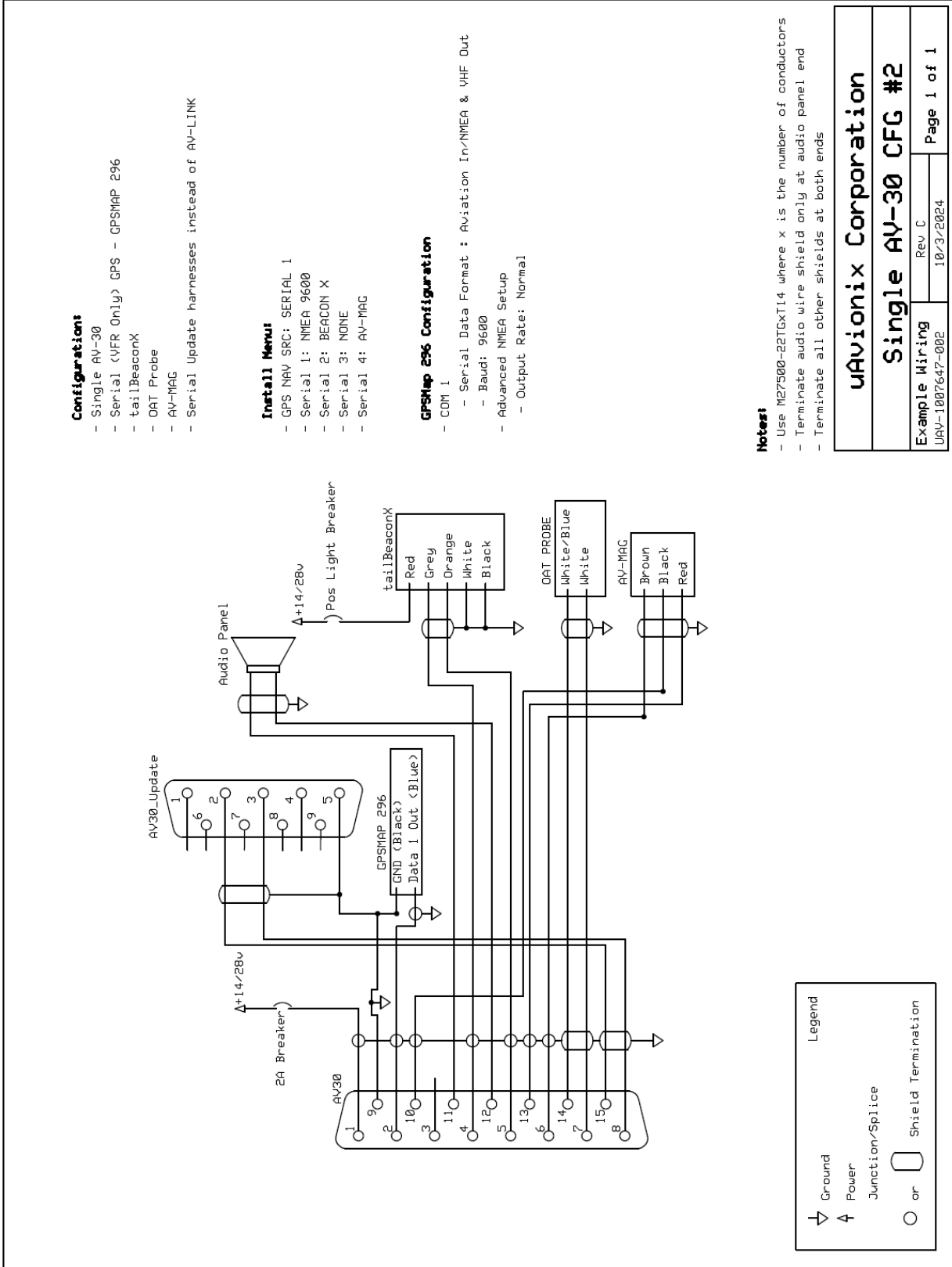

Configurations:

- Single AV-30
- Serial (VFR Only) GPS - GPSMAP 296
- tailBeaconX
- OAT Probe
- AV-MAG
- Serial Update harnesses instead of AV-LINK

Install Menu:

- GPS NAV SRC: SERIAL 1
- Serial 1: NMEA 9600
- Serial 2: BEACON X
- Serial 3: NONE
- Serial 4: AV-MAG

GPSMap 296 Configuration:

- COM 1
 - Serial Data Format : Aviation In/NMEA & VHF Out
 - Baud: 9600
- Advanced NMEA Setup
 - Output Rate: Normal

Notes:

- Use M27500-22TGxT14 where x is the number of conductors
- Terminate audio wire shield only at audio panel end
- Terminate all other shields at both ends

uAvionix Corporation	
Single AV-30 CFG #2	
Example Wiring UAV-1007647-002	Rev. C 10/3/2024
Page 1 of 1	

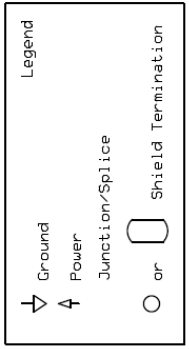

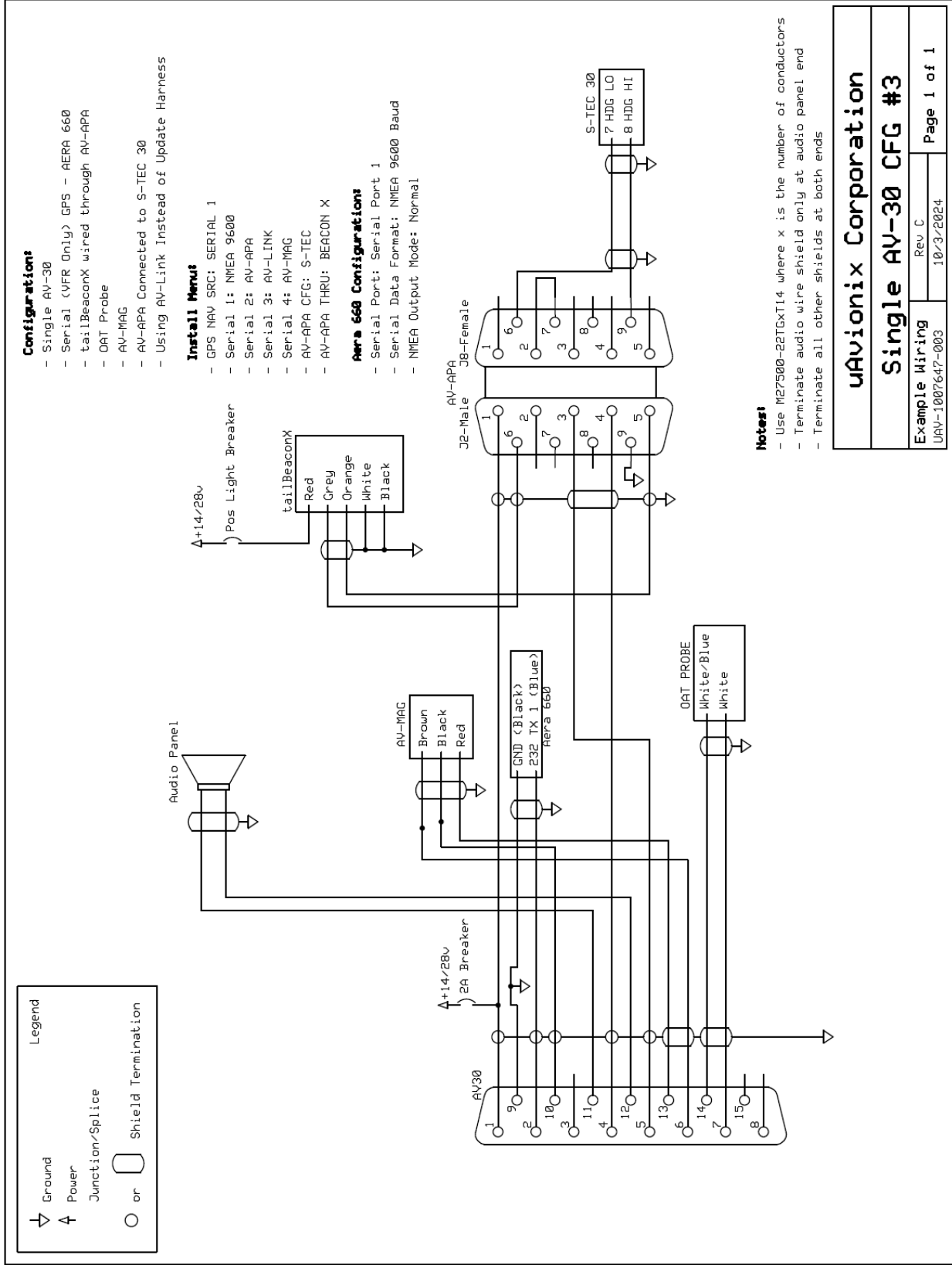

Configuration:

- Single AV-30
- AV-HSI with IFD/GNS IFR GPS
- DAT Probe
- AV-MAG
- Using AV-Link Instead of Update Harness

Install Menu:

- GPS NAV SRC: SERIAL 1
- Serial 1: AV-HSI
- Serial 2: Pro Pilot
- Serial 3: AV-LINK
- Serial 4: AV-MAG
- AV-HSI Port Speeds: match navigator

IFD/GNS Configuration:

- A429 Data In: EFIS/Airdata
- A429 Data Out: GAMA 429

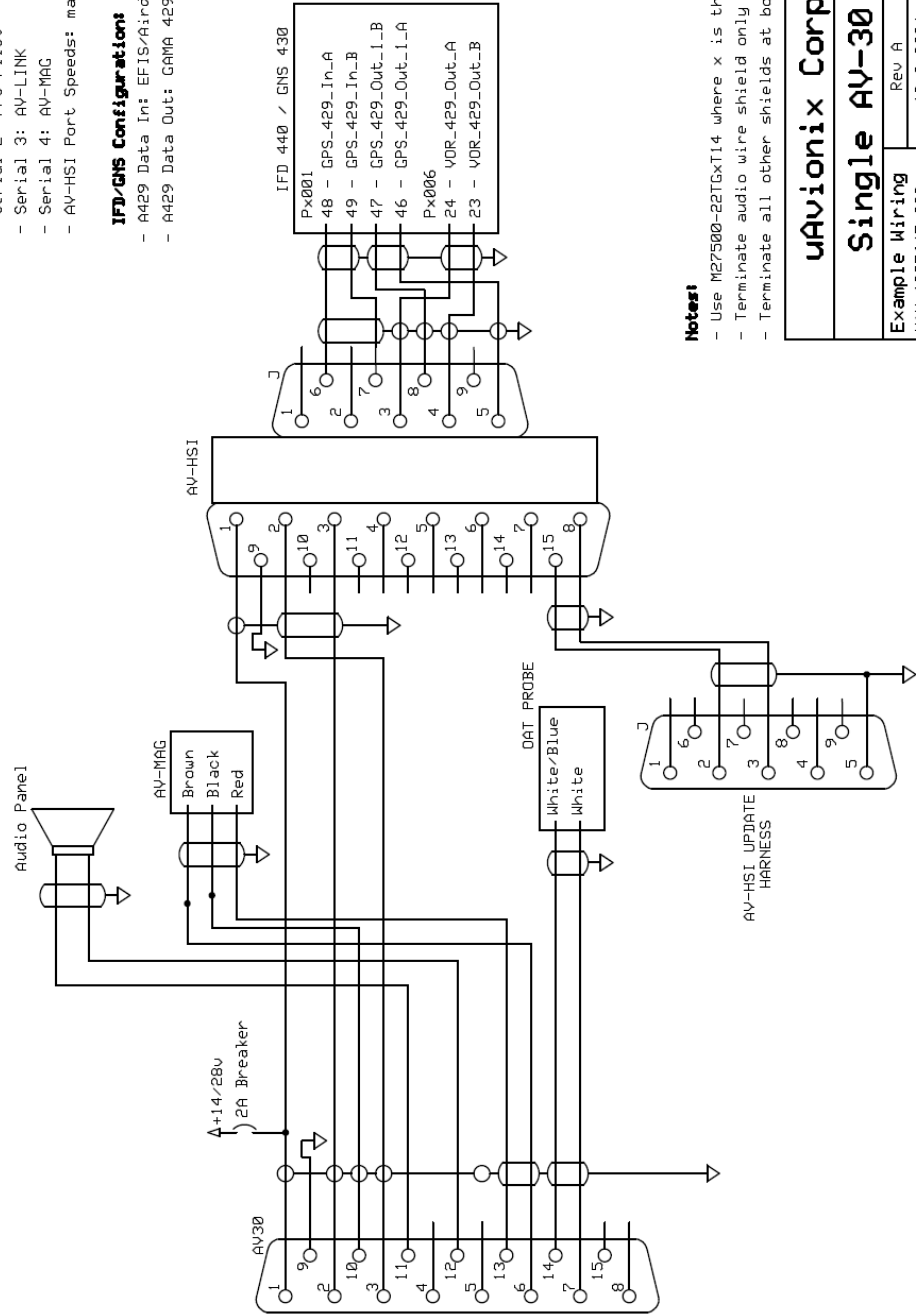

Notes:

- Use M27500-22TGxT14 where x is the number of conductors
- Terminate audio wire shield only at audio panel end
- Terminate all other shields at both ends

uAvionix Corporation
Single AV-30 CFG #5

Example Wiring	Rev A	Page 1 of 1
UAV-1007647-009	10/3/2024	

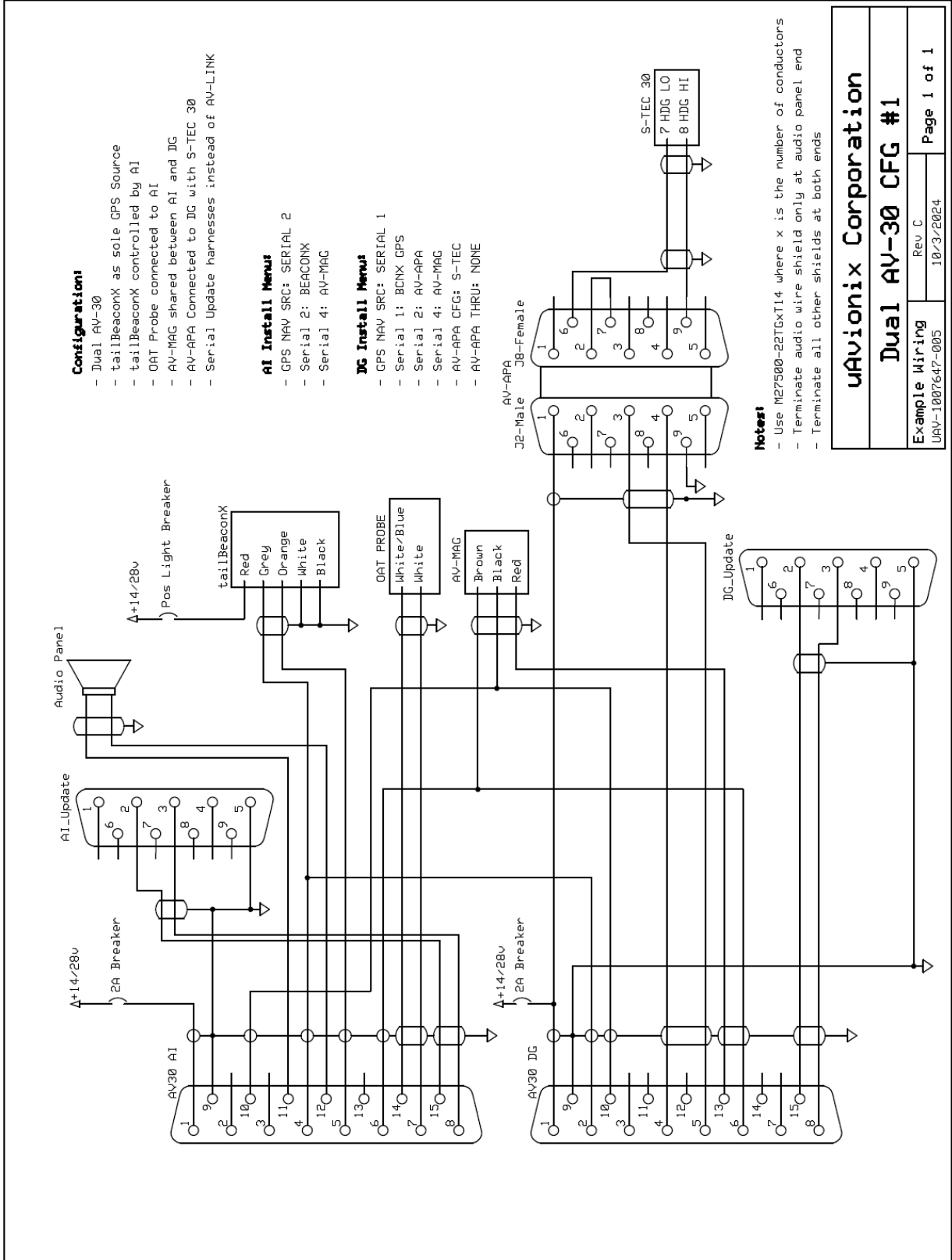

Configurations

- Dual AV-30
- tailBeaconX as sole GPS Source
- tailBeaconX controlled by AI
- OAT Probe connected to AI
- AV-MAG shared between AI and DG
- AV-APA Connected to DG with S-TEC 30
- Serial Update harnesses instead of AV-LINK

AI Install Menu

- GPS NAV SRC: SERIAL 2
- Serial 2: BEACONX
- Serial 4: AV-MAG

DG Install Menu

- GPS NAV SRC: SERIAL 1
- Serial 1: BCINX GPS
- Serial 2: AV-APA
- Serial 4: AV-MAG
- AV-APA CFG: S-TEC
- AV-APA THRU: NONE

Notes

- Use M27500-22TGxT14 where x is the number of conductors
- Terminate audio wire shield only at audio panel end
- Terminate all other shields at both ends

uAvionix Corporation
Dual AV-30 CFG #1

Example Wiring	Rev C
UAV-1007647-005	10/3/2024
Page 1 of 1	

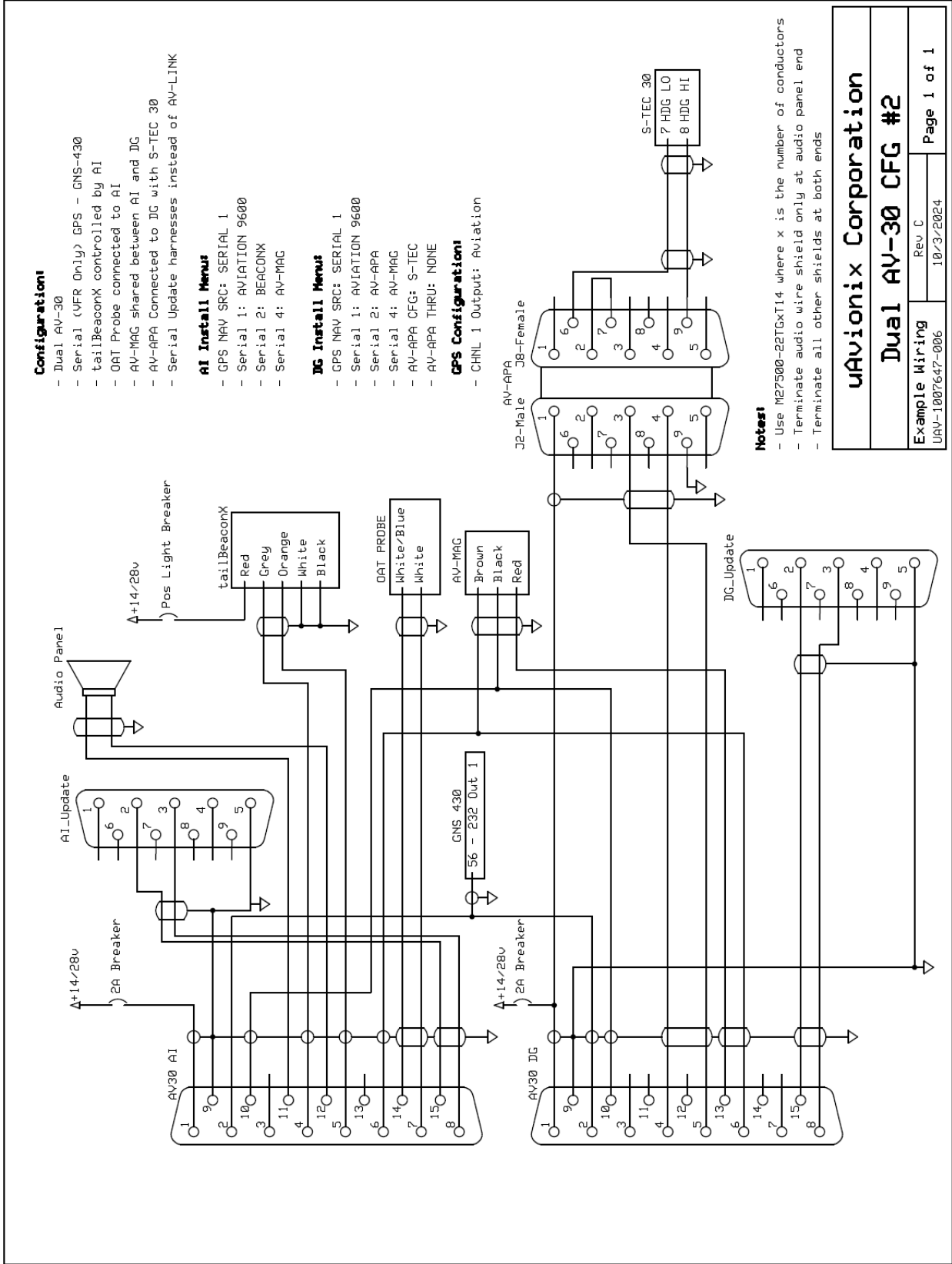

Configuration:

- Dual AV-30
- Serial (VFR Only) GPS - GNS-430
- tailBeaconX controlled by AI
- OAT Probe connected to AI
- AV-MAG shared between AI and IIG
- AV-APA Connected to IIG with S-TEC 30
- Serial Update harnesses instead of AV-LINK

AI Install Menu:

- GPS NAV SRC: SERIAL 1
- Serial 1: AVIATION 9600
- Serial 2: BEACONX
- Serial 4: AV-MAG

IIG Install Menu:

- GPS NAV SRC: SERIAL 1
- Serial 1: AVIATION 9600
- Serial 2: AV-APA
- Serial 4: AV-MAG
- AV-APA CFG: S-TEC
- AV-APA THRU: NONE

GPS Configuration:

- CHNL 1 Output: Aviation

Notes:

- Use M27500-22TGx114 where x is the number of conductors
- Terminate audio wire shield only at audio panel end
- Terminate all other shields at both ends

Avionix Corporation	
Dual AV-30 CFG #2	
Example Wiring	Rev C
UAV-1007647-006	10/3/2024
Page 1 of 1	

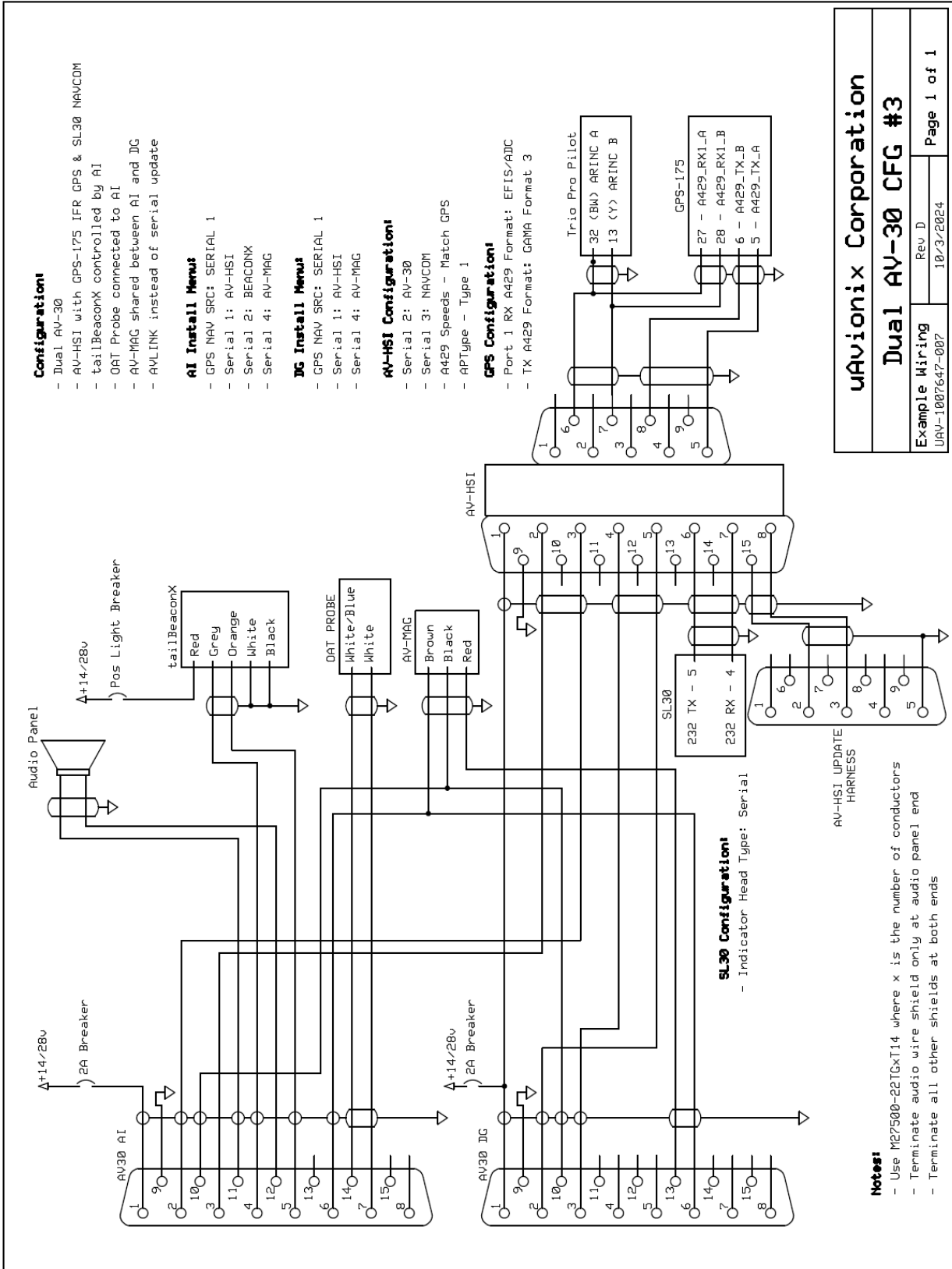

uAvionix Corporation	
Dual AV-30 Cfg #3	
Example Wiring	Rev D
UAV-1007647-007	10/3/2024
Page 1 of 1	

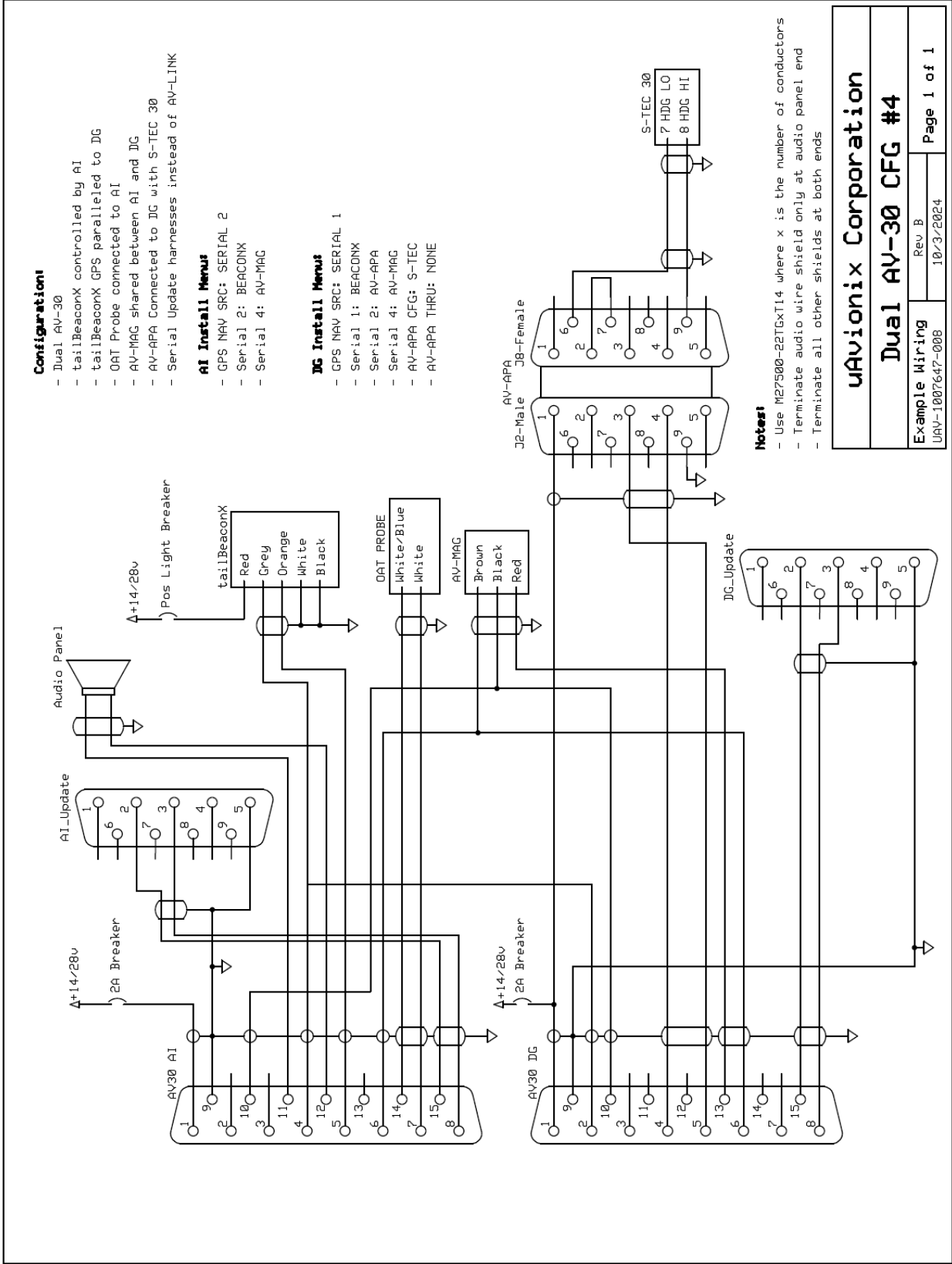

Configuration

- Dual AV-30
- tailBeaconX controlled by AI
- tailBeaconX GPS paralleled to DG
- OAT Probe connected to AI
- AV-MAG shared between AI and DG
- AV-APA Connected to DG with S-TEC 30
- Serial Update harnesses instead of AV-LINK

AI Install Menu

- GPS NAV SRC: SERIAL 2
- Serial 2: BEACONX
- Serial 4: AV-MAG

DG Install Menu

- GPS NAV SRC: SERIAL 1
- Serial 1: BEACONX
- Serial 2: AV-APA
- Serial 4: AV-MAG
- AV-APA CFG: S-TEC
- AV-APA THRU: NONE

Notes

- Use M27500-22TGxT14 where x is the number of conductors
- Terminate audio wire shield only at audio panel end
- Terminate all other shields at both ends

uAvionix Corporation	
Dual AV-30 CFG #4	
Example Wiring	Rev B
UAV-1007647-008	10/3/2024
Page 1 of 1	

18 List of figures

Figure 1 – AV-30 Multi Mode AI/DG/MFD/Transponder – Basic Display	15
Figure 2 – Mechanical Gauge Replacement	23
Figure 3 – AV-30 Aircraft Systems Interfaces – AI Mode	24
Figure 4 – AV-30 Aircraft Systems Interfaces – DG Mode	25
Figure 5 – Mechanical Drawing with Standard Li-Ion Battery	37
Figure 6 – Mechanical Drawing with Extended NiMH Battery	38
Figure 7 – Mounting Screw Depth Limits.....	39
Figure 8 – Install tool used for Top and Bottom Screw Engagement Check	40
Figure 9 – Proper Screw Engagement Adjustment	40
Figure 10 – Bridging using back side of tool when working with enlarged holes and reducing washers.....	43
Figure 11 – Wiring Diagram – Required Connections.....	44
Figure 12 – Wiring Diagram – Optional Connections 1 of 2	45
Figure 13 – Wiring Diagram – Optional Connections 2 of 2	46
Figure 14 – Ground Braid Strap – 8” or Less in Length	47
Figure 15 – Shielded Cable	47
Figure 16 – Cable Shields and Ground Strap	48
Figure 17 – Unit Connections – DB-15, Male (Rear Unit View)	50
Figure 18 – AV-Link Mechanical Drawing	53
Figure 19 – AV-Link Backshell Connector Removal.....	54
Figure 20 – AV-Link attachment	55
Figure 21 – AV-Link installed	56
Figure 22 – AV-Link attachment with backshell	56
Figure 23 – Parallel tailBeaconX GPS Connections	63
Figure 24 – AV-Mag Mechanical Drawing.....	65
Figure 25 – AV-Mag Orientation Reference	74
Figure 26 – MAG CAL Flag and AVMAG CAL Selection	77
Figure 27 – AVMAG Calibration Entry.....	78
Figure 28 – AVMAG CAL In-Progress	79
Figure 29 – AVMAG CAL Orientation Guide.....	80
Figure 30 – AVMAG CAL Success and Failure Screens	81
Figure 31 – AV-APA Mechanical Drawing	84
Figure 32 – AV-APA Connectors.....	85
Figure 33 – AV-APA – AV-30 Interconnect Drawing	92
Figure 34 – AV-APA – S-TEC Interconnect	93
Figure 35 – AV-HSI – ARINC 429 Autopilot Interconnect.....	102
Figure 36 – AV-HSI – Autopilot Interconnect Without Advanced AP Unlock	103
Figure 37 – AV-HSI Mechanical Drawing	109
Figure 38 – AV-HSI – AV-30 Interconnect Drawing.....	113
Figure 39 – AV-HSI – Serial NAVCOM Interconnect Drawing	114
Figure 40 – AV-HSI – ARINC 429 Interconnect Drawing	115

Figure 41 – AV-HSI Update Harness.....	116
Figure 42 – AV-HSI Update With AV-30 Using Serial 4	117
Figure 43 – State Sync Menu	131
Figure 44 – Splash Screen	132
Figure 45 – Common User Interface Components	133
Figure 46 – Installation Menu Access	135
Figure 47 – Installation Menu Access	136
Figure 48 – Exiting Edit Mode.....	136
Figure 49 – Setup Done / Exit Option	137
Figure 50 – AID Mode Selection	147
Figure 51 – Aligning Annunciator	148
Figure 52 – Install Mode Selection	149
Figure 53 – Gyro Calibration Selection	150
Figure 54 – Gyro Calibration Procedure	150
Figure 55 – MAG CAL Flag and INT MAG CAL Selection.....	151
Figure 56 – INT MAG CAL Entry and Progress	151
Figure 57 – INT MAG CAL Success and Failure Screens	152
Figure 58 – OAT Indicator	154
Figure 59 – GPS Data Elements.....	154
Figure 60 – Vibe Monitor Selection	155
Figure 61 – Vibe Monitor Operation.....	156
Figure 62 – Field Update Interface Diagram	170

19 List of tables

Table 1 – System Specifications	19
Table 2 – Applicable Performance Standards	21
Table 3 – Feature Matrix	27
Table 4 – GPS Functions by receiver type	30
Table 5 – Supplied Components	35
Table 6 – Non-Supplied Components	36
Table 7 – Connector Pinout	49
Table 8 – AV-Link Specifications	52
Table 9 – AV-Mag Specifications	65
Table 10 – AV-Mag Wiring Guide	66
Table 11 – AV-Mag Orientation Options	73
Table 12 – Supported Autopilots	83
Table 13 – AV-APA Specifications	84
Table 14 – AV-APA Pinout	86
Table 15 – AV-HSI Compatible GPS Navigators	107
Table 16 – AV-HSI Compatible NAV/COMM	108
Table 17 – AV-HSI Specifications	109
Table 18 – AV-HSI DB15 Pinout	110
Table 19 – AV-HSI DB9 Pinout	110
Table 20 – AV-HSI Configuration Options	121
Table 21 – Avidyne IFD 410/440/510/540/545, Garmin GPS-400(W)/500(W), GNC-420(W), GNS-430(W)/530(W) Configuration	122
Table 22 – Garmin GPS-155XL, GNC-300XL Configuration	123
Table 23 – Apollo CX80, Garmin GNS-480 Configuration	123
Table 24 – Garmin GTN-625(xi), GTN-635(xi), GTN-650(xi), GTN-725(xi), GTN-750(xi) Configuration	124
Table 25 – Garmin GPS-175, GNC-355, GNX-375 Configuration	125
Table 26 – Garmin GNC-215 Configuration	125
Table 27 – Garmin GNC-255 Configuration	126
Table 28 – Apollo/Garmin SL-30 Configuration	126
Table 29 – Trig TX56(a)/TX57(a) Configuration	127
Table 30 – MGL N16 Configuration	127
Table 31 – VAL NAV 2000 Configuration	127
Table 32 – Installation Menu Settings	140
Table 33 – AV-Mag Submenu	141
Table 34 – AV-HSI Submenu	142
Table 35 – AV-Mag Installation Parameters	153
Table 36 – Calibrated Heading Check	153
Table 37 – Troubleshooting	166
Table 38 – GPS Serial Specification	167
Table 39 – ARINC 429 Receive Specification	169

Table 40 – ARINC 429 Transmit Specification169