

# AV-30-E

## PILOT'S GUIDE



Rev L  
UAV-1004233-001

# Copyright and Privacy Notice

Except as expressly provided herein, no part of this guide may be reproduced, transmitted, disseminated, downloaded, or stored in any storage medium, for any purpose without the express written permission of uAvionix. uAvionix grants permissions to download a single copy of this guide onto an electronic storage medium to be viewed for personal use, provided that the complete text of this copyright notice is retained. Unauthorized commercial distribution of this manual or any revision hereto is strictly prohibited.

uAvionix® and Ping® are registered trademarks of uAvionix Corporation and may not be used without express permission of uAvionix.

AV-30, AV-30-E, AV-30-C, AV-Link, AV-Link-E, AV-Link-C, AV-Mag, AV-APA, AV-HSI, BeaconX, tailBeaconX, and skyBeaconX are trademarks of uAvionix Corporation and may not be used without express permission of uAvionix.

© 2020 - 2025 uAvionix Corporation. All rights reserved.

uAvionix Corporation  
Bigfork, MT

General: [www.uavionix.com](http://www.uavionix.com)  
Support: [support@uavionix.com](mailto:support@uavionix.com)  
Patents [uavionix.com/patents](http://uavionix.com/patents)

## Limited Warranty

uAvionix products are warranted to be free from defects in material and workmanship for two years from the installation of AV-30-E on the aircraft. For the duration of the warranty period, uAvionix, at its sole option, will repair or replace any product which fails in normal use. Such repairs or replacement will be made at no charge to the customer for parts or labor, provided that the customer shall be responsible for any transportation cost.

Disclaimer of Warranty: IN NO EVENT, SHALL UAVIONIX BE LIABLE FOR ANY INCIDENTAL, SPECIAL, INDIRECT OR CONSEQUENTIAL DAMAGES, WHETHER RESULTING FROM THE USE, MISUSE, OR INABILITY TO USE THE PRODUCT OR FROM DEFECTS IN THE PRODUCT. SOME STATES DO NOT ALLOW THE EXCLUSION OF INCIDENTAL OR CONSEQUENTIAL DAMAGES, SO THE ABOVE LIMITATIONS MAY NOT APPLY TO YOU.

Restrictions: This warranty does not apply to cosmetic damage, consumable parts, damage caused by accident, abuse, misuse, fire or flood, theft, damage caused by unauthorized servicing, or product that has been modified or altered.

Warranty Service: Warranty repair service shall be provided directly by uAvionix. Proof of purchase for the product from uAvionix or authorized reseller is required to obtain and better expedite warranty service. Please email or call uAvionix support with a description of the problem you are experiencing. Also, please provide the model, serial number, shipping address and a daytime contact number. You will be promptly contacted with further troubleshooting steps or return instructions. It is recommended to use a shipping method with tracking and insurance.

## Warnings / Disclaimers

All device operational procedures must be learned on the ground. uAvionix is not liable for damages arising from the use or misuse of this product.

This equipment is classified by the United States Department of Commerce's Bureau of Industry and Security (BIS) as Export Control Classification Number (ECCN) 7A994.

These items are controlled by the U.S. Government and authorized for export only to the country of ultimate destination for use by the ultimate consignee or end-user(s) herein identified. They may not be resold, transferred, or otherwise disposed of, to any other country or to any person other than the authorized ultimate consignee or end-user(s), either in their original form or after being incorporated into other items, without first obtaining approval from the U.S. Government or as otherwise authorized by U.S. law and regulations.

# 1 Revision History

Revision	Date	Comments
A	6/2/2020	Initial release.
B	5/4/2021	Add AV-Link feature. Add traffic display feature. Add transponder control feature.
C	5/20/2021	§7.5.5 Correction of non-slaved DG
D	7/22/2021	Added features of tailBeaconX and software update aiding features.
E	1/5/2022	Added AeroCruze 100/TruTrak Vizion autopilot control feature.
F	4/12/2022	Added AV-Mag external magnetometer.
G	10/11/2022	Added Set Altitude (SALT) visual alert. Changed TRUTRAK to AEROCRUZE. Added Trio PRO PILOT autopilot support. Added AV-Link reset feature. Added direct turn adjustment of barometer and heading bug. Added overlay elements on DG screens to support altitude controlling autopilots. Modified heading bug display to synchronize with autopilot usage. Modified PUSH-SET menu sequences to better support autopilot inputs. Missing magnetometer calibration now flagged with “MAG CAL” rather than “NO MAG”. Added a “zero out” action of the DG adjustment if using AV-Mag. Added table of checks and alerts for stored parameter integrity. Added three new autopilot heading modes and descriptions. Added GPS error messages table. Added AI screenshots illustrating 1:3, 2:3, 3:3 default screens.
H	2/27/2023	Updated Angle Of Attack Limit setting instructions to match the AV-30-C Pilot’s Guide. Updated CRC check splash messages. Update AV-Link for latest release (0.3.0) and new IP (192.168.5.1).
I	12/6/23	Update for firmware version 2.4.1. Add AV-APA. Add Carbon Monoxide Overlay and Alert. Add GPS Rose, GPS HSI, and GPS ARC modes. Update guidance on vertical trend indicator specifying SVS bug requires digital autopilot. Update 5.8 with new MFD status message descriptions/locations and guidance about fallback GPS source. Update AV-Link sections for latest release (0.3.2). Update Table 11 – Operating Limits with expanded DALT Operational Range. Update 5.5.3 to indicate ALIGN flag can appear on all pages. Update 5.6.6 to indicate that entire flight plan is shown when using Aviation format. Update 5.5.7 for addition of hectopascals as an option for barometric setting. Update 5.2 with note about “SET BARO” quick-reset and recall. Update 5.11 with new squawk/flight ID/mode/VFR edit flow. Update 5.5.5 with new KPH option for IAS units. Update 4.4 to indicate ground speed units match IAS units.

		<p>Add pitot static attitude aiding</p> <p>Update Mode C rebroadcast description in 7.8.9.1</p>
J	4/5/2024	<p>Add AV-HSI functionality throughout document</p> <p>Add new §7.12 CDI Mode</p> <p>Add ARINC 429 Autopilot option to §14</p>
K	7/12/2024	<p>Add VSI on MFD in §5.1, Table 7-3, and §7.8.9.3.</p> <p>Add GPS "MSG" indicator to §7.5.11 and §7.9.</p> <p>Add Turn Coordinator function to §5, §7.5.4, and Table 12-1.</p> <p>Add G Min and Max hold to §5.2, Table 7-2, and Table 12-1.</p> <p>Add Rate of Climb to §5.2 and Table 7-2.</p> <p>Add reference to AV-Link connected to AV-HSI to §6.8.</p> <p>Removed VFR indication from DG Arc when connected with AV-HSI in §7.6.6.</p> <p>Add over and under voltage alert thresholds to Table 12-1.</p>
L	1/8/2025	<p>Global formatting updates.</p> <p>Add Bus Voltage and G-Min/Max Reset to 5.7.</p> <p>Add transponder control overlay to 5.11.</p> <p>Add track bug description to 5.2.</p> <p>Update 5.12 to reflect updated brightness menu.</p>

# 2 Table of Contents

COPYRIGHT AND PRIVACY NOTICE.....	2
LIMITED WARRANTY.....	3
WARNINGS / DISCLAIMERS.....	4
<b>1 REVISION HISTORY .....</b>	<b>5</b>
<b>2 TABLE OF CONTENTS .....</b>	<b>7</b>
<b>3 AV-30 SYSTEM INFORMATION .....</b>	<b>11</b>
3.1 SYSTEM DESCRIPTION .....	11
3.2 SYSTEM FUNCTIONS .....	13
<b>4 UNIT INTERFACES.....</b>	<b>15</b>
4.1 AIRCRAFT SYSTEMS INTERFACES.....	15
4.2 POWER INPUT (REQUIRED).....	16
4.3 PITOT AND STATIC INTERFACES (REQUIRED) .....	17
4.4 GPS INTERFACE (OPTIONAL).....	17
4.5 OAT PROBE (OPTIONAL) .....	17
4.6 AUDIO OUTPUT (OPTIONAL).....	18
4.7 TRANSPONDER CONTROL (OPTIONAL).....	18
4.8 AV-LINK INTERFACE (OPTIONAL) .....	18
4.9 MAGNETOMETER AIDING (OPTIONAL).....	19
4.10 AUTOPILOT (OPTIONAL) .....	19
4.10.1 AV-APA – Analog Port Adapter (Optional).....	20
4.10.2 Digital Autopilots – RS-232 (Optional).....	20
4.10.3 Digital Autopilots – ARINC-429 (Optional).....	21
4.11 AV-HSI – HORIZONTAL SITUATION INDICATOR (OPTIONAL).....	21
4.12 ELECTRONIC FLIGHT INSTRUMENT SYSTEM (EFIS) (OPTIONAL).....	21
<b>5 USER INTERFACE .....</b>	<b>22</b>
5.1 STARTUP AND COMMON CONTROLS.....	22
5.2 “PUSH-SET” CONTROL .....	23
5.3 DIRECT-TURN.....	26
5.4 USER INTERFACE CUSTOMIZATION.....	26
5.4.1 AI Mode Customization.....	28
5.4.2 Edit Presented Data .....	30
5.5 AI MODE DISPLAY COMPONENTS .....	30
5.5.1 Basic Components.....	30
5.5.2 Customizable Data Overlay Fields.....	31
5.5.3 Attitude / Slip.....	32
5.5.4 Turn Coordinator.....	33
5.5.5 Airspeed Indicator.....	34
5.5.6 Flight Direction Indicator .....	36
5.5.7 Barometric Corrected Altitude Indicator.....	36
5.5.8 AoA Indication.....	37
5.5.9 Vertical Trend Indicator .....	38

5.5.10	<i>G-Load Indicator</i>	40
5.5.11	<i>Course Deviation and Glideslope Indicator</i>	40
5.5.12	<i>Text Fields</i>	42
5.5.13	<i>Accessing Reversionary AI</i>	43
5.6	DG MODE DISPLAY COMPONENTS	43
5.6.1	<i>DG Mode Customization</i>	43
5.6.2	<i>Non-Slaved Heading Rose Mode</i>	44
5.6.3	<i>GPS-Slaved Heading Rose Mode</i>	44
5.6.4	<i>Non-Slaved HSI Mode</i>	44
5.6.5	<i>GPS-Slaved HSI Mode</i>	47
5.6.6	<i>Non-Slaved ARC Mode</i>	47
5.6.7	<i>GPS ARC Mode</i>	49
5.6.8	<i>Operational Aspects</i>	49
5.6.9	<i>Accessing Reversionary AI</i>	51
5.7	AI / DG DISPLAYABLE PARAMETERS	51
5.7.1	<i>Bus Voltage Threshold</i>	53
5.7.2	<i>G-Min and G-Max Reset</i>	53
5.8	MFD MODE	53
5.8.1	<i>Features</i>	54
5.8.2	<i>Firmware Update</i>	55
5.8.3	<i>Display Functions</i>	56
5.8.4	<i>Display Zoom</i>	57
5.8.5	<i>Target Relative Altitude</i>	58
5.8.6	<i>Target Airspeed</i>	59
5.8.7	<i>Target Tracking Function</i>	59
5.8.8	<i>Accessing Reversionary AI</i>	60
5.8.9	<i>Traffic Mode Configuration</i>	60
5.8.9.1	<i>Ownship ICAO</i>	60
5.8.9.2	<i>Traffic Filtering</i>	61
5.8.9.3	<i>Vertical Speed Overlay</i>	63
5.9	CDI MODE	63
5.10	REVERSIONARY AI	64
5.11	TRANSPONDER CONTROL	65
5.11.1	<i>Reversionary AI Transponder Control</i>	65
5.11.1.1	<i>Status</i>	65
5.11.1.2	<i>Changing Squawk</i>	66
5.11.1.3	<i>Changing Flight ID</i>	67
5.11.1.4	<i>Changing Transponder Mode</i>	67
5.11.1.5	<i>To Send IDENT</i>	67
5.11.1.6	<i>Quick Squawk VFR</i>	68
5.11.2	<i>Squawk Overlay</i>	68
5.12	BRIGHTNESS MENU	69
<b>6</b>	<b>USER INTERFACE AND FONT STYLE OPTIONS</b>	<b>70</b>
<b>7</b>	<b>ALERTS AND ALERT LIMITS</b>	<b>71</b>
7.1	AIRFRAME ENVELOPE ALERTS	71
7.2	ALTITUDE ALERT	72
7.3	CARBON MONOXIDE ALERT	72
7.4	ATTITUDE MISCOMPARE ALERT	73



<b>8</b>	<b>INTERNAL BATTERY OPERATION .....</b>	<b>74</b>
8.1	GENERAL.....	74
8.2	BATTERY TRANSITION LOGIC .....	74
8.2.1	<i>Power-On Self-Test (Pre-Flight)</i> .....	74
8.2.2	<i>Power Loss, Airspeed Above 40 Knots (In-Flight)</i> .....	75
8.2.3	<i>Power Loss, Airspeed Below 40 Knots (On-Ground)</i> .....	75
8.3	BATTERY CHARGE STATUS .....	75
<b>9</b>	<b>AOA OPERATION AND CONFIGURATION .....</b>	<b>77</b>
9.1	OPERATIONAL METHODOLOGY .....	77
9.2	CONFIGURED LIMITS.....	78
9.3	STABLE FLIGHT CONDITIONS.....	79
9.4	SETTING AOA UPPER LIMIT .....	79
9.5	SETTING AOA LOWER LIMIT.....	80
9.6	AOA ALERT TYPES AND THRESHOLDS.....	81
9.7	FLAP SETTING OBSERVATIONS .....	81
<b>10</b>	<b>SETUP MENU.....</b>	<b>83</b>
10.1	PILOT-ACCESSIBLE SETUP MENU .....	84
10.2	NON-PILOT ACCESSIBLE INSTALL MENU.....	85
<b>11</b>	<b>AV-LINK.....</b>	<b>86</b>
11.1	OVERVIEW .....	86
11.2	ADDITIONAL REQUIRED EQUIPMENT .....	86
11.3	CONNECTING.....	87
11.4	HOME PAGE.....	88
11.4.1	<i>Settings</i> .....	88
11.4.2	<i>Status</i> .....	88
11.4.3	<i>Device Information</i> .....	88
11.4.4	<i>Navigating to Other Pages</i> .....	89
11.5	WI-FI SETTINGS PAGE.....	89
11.5.1	<i>ADS-B Receiver Settings</i> .....	89
<b>12</b>	<b>AUTOPILOT .....</b>	<b>92</b>
12.1	AUTOPILOT MODES .....	92
12.1.1	<i>Heading Bug</i> .....	94
12.1.2	<i>Track Bug</i> .....	94
12.1.3	<i>GPS Steering (GPSS)</i> .....	94
12.1.4	<i>Desired Track to Waypoint</i> .....	94
12.1.5	<i>Bearing to Waypoint</i> .....	95
12.2	AUTOPILOT CONTROL.....	95
12.2.1	<i>Selecting Heading</i> .....	95
12.2.2	<i>Selecting Altitude</i> .....	95
12.2.3	<i>Selecting Vertical Speed</i> .....	95
12.2.4	<i>Selecting Autopilot Mode</i> .....	96
<b>13</b>	<b>STORED DATA INTEGRITY CHECK.....</b>	<b>97</b>
<b>14</b>	<b>OPERATING LIMITS &amp; SYSTEM SPECIFICATIONS .....</b>	<b>98</b>

15	LIST OF FIGURES .....	99
16	LIST OF TABLES .....	101

# 3 AV-30 System Information

## 3.1 System Description

The uAvionix AV-30 is a fully digital multi-mode instrument that mounts in the legacy 3-1/8” round instrument panel cutout typically found in light general aviation instrument panels. It can be field configured as either an Attitude Indicator (AI) or a Directional Gyro (DG) indicator, is fully self-contained with dual-precision inertial and pressure sensors and allows for a wide variety of pilot customization. With optional accessories, the AV-30 can also be configured as a Multi-Function Display (MFD) or Course Deviation Indicator (CDI).



Figure 1 – AV-30 Multi Mode AI/DG/Transponder – Basic Display

When configured as an AI, primary attitude and slip are always displayed. The unused portions of the display area can be customized by the pilot to show a variety of textual and graphical data-overlay fields. Up to three pages may be customized by the pilot while the last page presents a fully decluttered view of only attitude and slip or control of a compatible uAvionix ADS-B transponder such as the tailBeaconX.

When configured as a Directional Gyro (DG), non-slaved direction of flight information is presented. The non-slaved direction can be manually adjusted by pilot input, aided by the optional AV-Mag accessory, or may be optionally slaved to GPS track. Multiple display presentations, including compass rose, GPS HSI, and GPS arc views can be selected by the pilot. The unused portions of the display area can similarly be configured for a variety of textual data overlays.

With an optional AV-Link accessory, the AV-30 can be configured as a Multi-Function Display (MFD) that displays traffic from ADS-B receivers. MFD and DG modes are accessible when the AV-30 is configured as a DG. As with other operating modes, the last page provides a reversionary AI.

With an optional AV-HSI accessory, the AV-30 can be configured as a Course Deviation Indicator (CDI). Two CDI pages are available, with the third providing a reversionary AI. As with other modes, unused portions of the display area can be configured with textual data overlays.

In all operating modes, the pilot may select from multiple visual styles which are intended to improve visual compatibility with legacy aircraft instrumentation and preserve the look-and-feel of older aircraft applications.

When installed as a non-required instrument (not replacing the existing approved AI or DG), the functional mode of the unit can be toggled between AI, DG, MFD, and CDI modes by pressing and holding the center knob for 3 seconds.

## 3.2 System Functions

The AV-30 includes the following functions:

### Primary Functions

- Primary Attitude (AI Mode)
- Primary Slip (AI Mode)
- Primary Direction of Flight indication (DG Mode)
- Primary Navigation Information (with optional AV-HSI)

### Supplemental Functions

- Indicated Airspeed
- Altitude
- Rate of Turn
- Standard Rate Bank Angle
- V-Speeds
- Angle of Attack
- Vertical Trend
- Vertical Speed
- Set Altitude (SALT)
- Set Vertical Speed (SVS)
- Heading
- Bus Voltage
- G Load
- G-Max and G-Min Hold
- Outside Air Temperature
- True Airspeed
- Density Altitude
- GPS Navigator / Waypoint Data
- GPS Navigator / Flight Plan
- Rate of Climb in Feet per Nautical Mile
- Heading Bug
- Traffic page (requires AV-Link)
- Transponder control (AI / DG / MFD Mode)
- Autopilot control

### Audio and Visual Alerting Functions

- AoA Alerting
- G Limit Alerting
- Excessive Roll Alerting
- Set Altitude Alerting
- Attitude Miscompare (with AV-HSI)

- Carbon Monoxide (with AV-Link and Sentry)

#### Miscellaneous Functions

- Internal Battery Operation
- Auto/Manual Brightness

# 4 Unit Interfaces

## 4.1 Aircraft Systems Interfaces

The following describes each of the AV-30 system interconnects for AI, DG, MFD, and CDI installation configurations. Note that, as shown in Figure 2 – AV-30 Aircraft Systems Interfaces – AI Mode, that some interfaces are optional and may not be available in each installation.

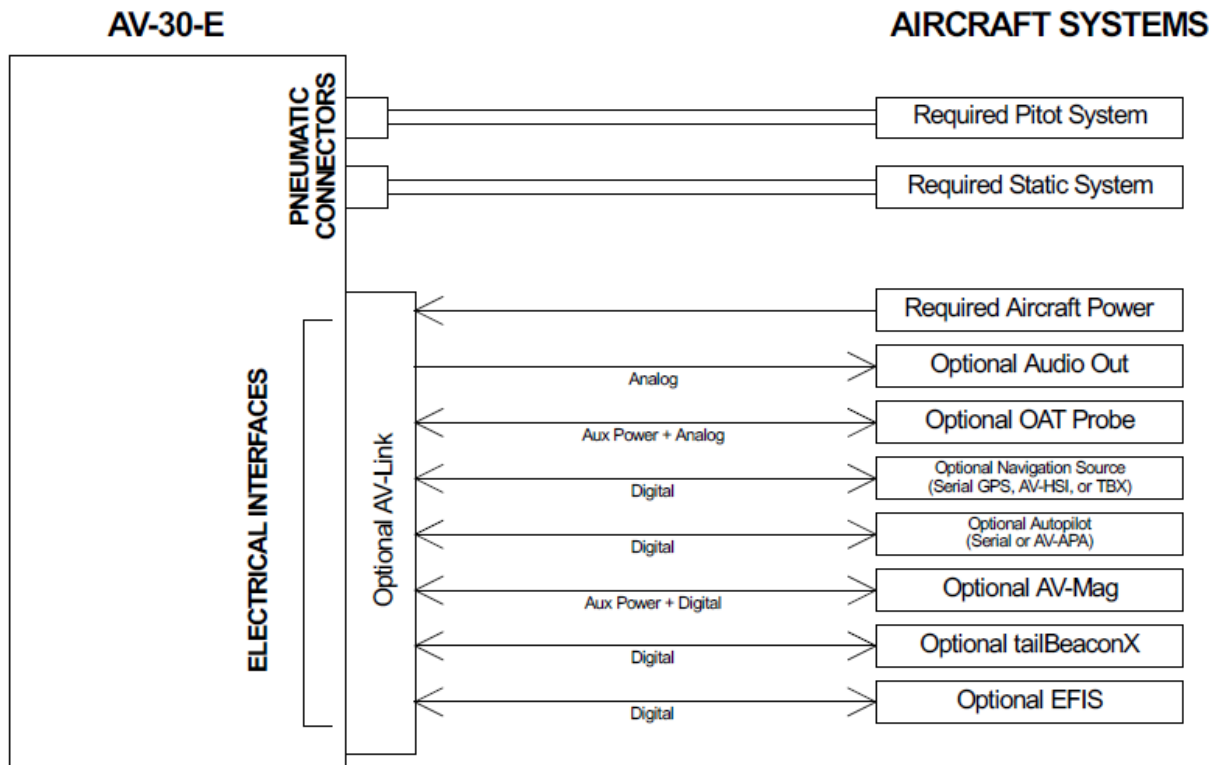

Figure 2 – AV-30 Aircraft Systems Interfaces – AI Mode

When installed as a DG, MFD, or CDI, no audio outputs are supported, and some air data related parameters are only available when the optional OAT probe is equipped.

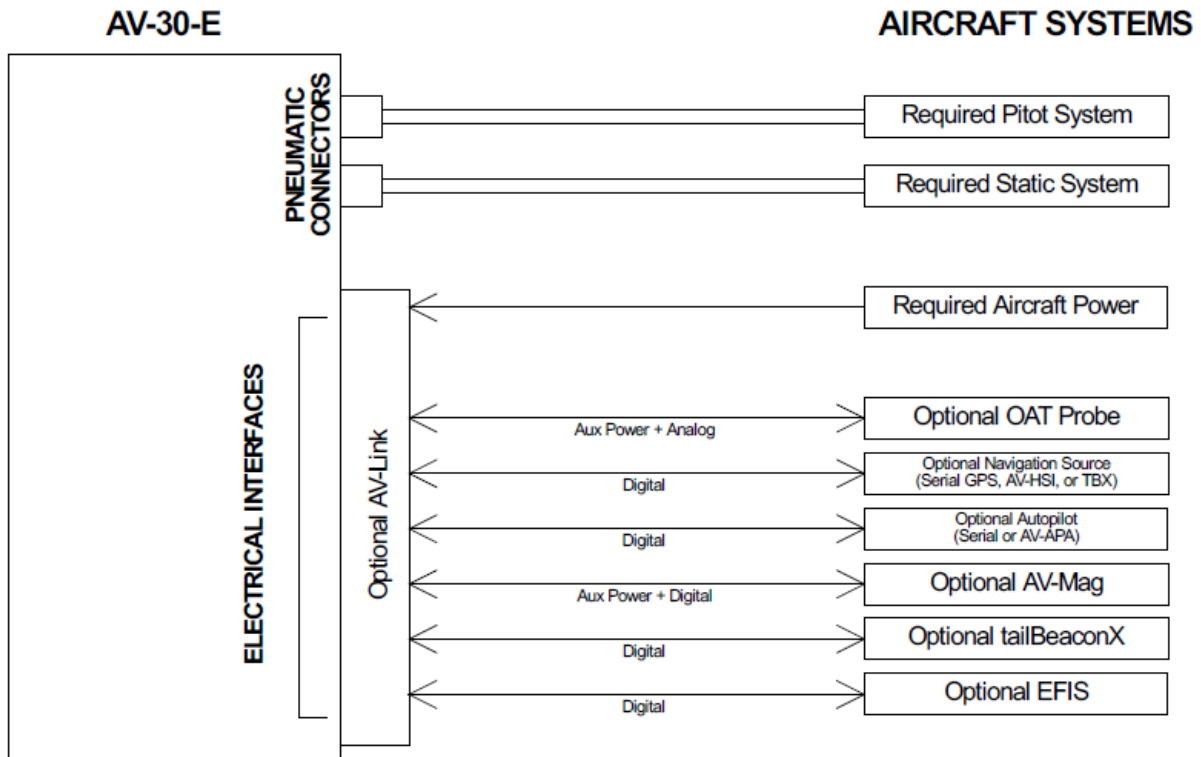

Figure 3 – AV-30 Aircraft Systems Interfaces – DG, MFD, or CDI Mode

## 4.2 Power Input (Required)

Power input is required in AI, DG, MFD, and CDI configurations and each unit has a dedicated circuit breaker. The power input is internally connected, and diode protected with the unit's internal battery via a processor-controlled switch. This architecture allows the unit to continue operation if external power fluctuates or is completely lost.

When external power is supplied to the AV-30, there is no mechanism to turn the unit off. When operating on battery, the unit may be forced off by pressing the left and right buttons simultaneously until the unit shuts off. See §8 - Internal Battery Operation for more information.

### NOTICE

The AV-Link, AV-APA, AV-HSI, and Transponder are not powered by the AV-30 internal battery. Wi-Fi traffic data provided to the MFD mode,



autopilot interface, navigation, and transponder functions will be unavailable during a power loss.

---

### **4.3 Pitot and Static Interfaces (Required)**

Pitot and static connections are required for all AV-30 installations.

Pitot and static data are used to populate screen overlays and aids the attitude solution.

### **4.4 GPS Interface (Optional)**

The AV-30 can interface with a Global Positioning System (GPS) receiver either directly or through an optional AV-HSI. GPS connected directly to the AV-30 do not provide IFR compliant navigation guidance. In this configuration, lateral deviation will be presented as VFR-only. No vertical guidance will be displayed.

IFR-capable navigators connected through an AV-HSI using ARINC 429 can provide IFR compliant lateral and vertical guidance for display on the AV-30. An AV-30 with an AV-HSI can display navigation guidance from one GPS and one VHF (VOR/ILS) source.

The AV-30 does not alter the data obtained from the GPS navigator and simply displays the received data in a textual or graphical format as configured by the pilot. The AV-30 will convert units of groundspeed to match units of airspeed.

The AV-30 can use a parallel input from a BeaconX to drive its GPS functions. A second AV-30 is required to act as the BeaconX Transponder Controller as per §4.7. Only one AV-30 may receive transponder data but both may receive GPS track and groundspeed from a single BeaconX.

### **4.5 OAT Probe (Optional)**

The optional Outside Air Temperature (OAT) probe interface is compatible with the industry standard “Davtron” (C307PS) probe which is mounted external to the aircraft. OAT data is available as a textual data overlay and is used to compute temperature dependent data such as True Airspeed (TAS) and Density Altitude (DALT). A single OAT probe cannot be wired to

multiple AV-30. However, the AV-HSI will share OAT data between connected AV-30s.

The OAT probe is automatically detected by the system, and when present, allows temperature related parameters to be selected for display. If the OAT probe is not detected, display of these parameters is inhibited.

## **4.6 Audio Output (Optional)**

The optional audio output provides audio alerts for the various alerting conditions. This output is typically connected to the aircraft's non-switched audio input on the audio panel. Audio alerting thresholds and alert enablement are configured by the pilot in the Setup Menu.

Audio alerting is only supported when configured as an AI.

## **4.7 Transponder Control (Optional)**

The AV-30 has the option of being the control interface for select uAvionix transponders (including the BeaconX family). This provides pressure altitude, mode, squawk code and IDENT information to the transponder, and displays status and annunciations from the transponder.

### **NOTICE**

The transponder is not powered by the AV-30 internal battery. Transponder operations will be unavailable during a power loss.

The BeaconX output can be shared in parallel between two AV-30 devices. One device must act as the Transponder Controller and the other may use the BeaconX as a GPS-only input.

---

## **4.8 AV-Link Interface (Optional)**

The AV-30 has the option of displaying ADS-B traffic using AV-Link as an integrated Wi-Fi bridge that allows for communication between AV-30 and Wi-Fi capable ADS-B receivers. The AV-30 will display a separate navigational page with traffic when configured and connected to a supported receiver.

If a Sentry ADS-B receiver is connected to the AV-Link, carbon monoxide data will be available as an overlay and as an alert on the AV-30.

## NOTICE

The AV-Link accessory is not powered by the AV-30 internal battery. Wi-Fi traffic data provided to the MFD mode will be unavailable during a power loss.

---

The AV-Link can be connected directly to an AV-HSI, sharing traffic and CO alerts to all connected AV-30. Additionally, this configuration enables software updates of the AV-HSI and all connected AV-30 from a single AV-Link.

### 4.9 Magnetometer Aiding (Optional)

Two magnetometer aiding devices are available: the AV-Mag external magnetometer and the internal magnetometer. Support for the AV-Mag external magnetometer is available in software version 2.3.0 or later and requires installation in the aircraft. If the AV-30 is equipped with an internal magnetometer (AV-30-E part number UAV-1004035-002) it will be automatically detected by software in versions 2.1.1 and later. Both types of magnetometers require calibration before use. Only one magnetometer can be used at a time. See §13 of the *AV-30-E Installation Manual UAV1004234-001* for details on how to calibrate either of the AV-30 magnetometers.

## NOTICE

The AV-Mag is powered by the AV-30. During a power loss, the AV-Mag will be powered by the AV-30 internal battery and continue to provide heading data.

---

### 4.10 Autopilot (Optional)

The AV-30 has the option to control analog or digital autopilots. Analog autopilots are controlled through the optional AV-APA accessory. Digital autopilots can be controlled either directly with RS-232 or with ARINC 429 through the AV-HSI.

#### 4.10.1 AV-APA – Analog Port Adapter (Optional)

The optional AV-APA enables direction control input to S-TEC 20/30/40/50/55/55X/60-1/60-2/65 autopilots. The AV-APA and AV-30 are connected to one another via RS-232 serial.

The AV-30 sends heading commands to the AV-APA which converts them to analog signals for the S-TEC autopilot. The pilot controls these via the center knob PUSH-SET menu. Information is displayed via graphical or text overlay fields.

### NOTICE

To process steering commands from the AV-APA, the S-TEC autopilot should be set to heading mode. Setting the S-TEC autopilot control head to track, navigation, or approach mode bypasses signals from the AV-APA and AV-30.

---

The AV-30 and AV-APA support six autopilot control modes. Each mode uses a different combination of desired direction and current direction to achieve different types of flight goals as shown in Table 9 – Autopilot Modes. For further details on Autopilot control see §12 *Autopilot*.

Altitude is not controlled through the AV-APA. Altitude functions of your S-TEC, if equipped, are controlled through the autopilot control head.

#### 4.10.2 Digital Autopilots – RS-232 (Optional)

The AV-30 can also directly act as an altitude and direction control input for the BendixKing AeroCruze 100/xCruze 100/TruTrak Vizion (385 and PMA) autopilot or the Trio 'Pro Pilot' autopilot. The autopilot and AV-30 are connected to one another via half duplex RS-232 serial.

The AV-30 sends a Set Altitude (SALT), a current altitude, a Set Vertical Speed (SVS), a desired direction, and a current direction to the autopilot. The pilot controls these via the center knob PUSH-SET menu and displays the data via graphical or textual overlay fields.

There are six autopilot control modes. Each mode uses a different combination of desired direction and current direction to achieve different

types of flight goals as shown in Table 9 – Autopilot Modes. For further details on Autopilot control see §12 *Autopilot*.

#### **4.10.3 Digital Autopilots – ARINC-429 (Optional)**

When equipped with an AV-HSI the AV-30 can control Aerocruze and Pro Pilot autopilots using ARINC 429.

The AV-30 and AV-HSI sends the heading bug and Set Altitude (SALT) to the autopilot. Additionally, when equipped with the Advanced Autopilot Unlock and an ARINC-429 GPS Navigator, GPS Steering commands are forwarded to the autopilot. The pilot controls autopilot mode, heading bug, and set altitude via the center knob PUSH-SET menu and displays the data via graphical or textual overlay fields.

There are two autopilot control modes used with ARINC 429 autopilots – heading bug and GPSS. For further details on Autopilot control see §12 *Autopilot*.

#### **4.11 AV-HSI – Horizontal Situation Indicator (Optional)**

The optional AV-HSI accessory can be connected to one GPS navigator capable of IFR enroute navigation and approaches to LPV minimums and one VHF navigator capable of VOR enroute and ILS approaches.

#### **4.12 Electronic Flight Instrument System (EFIS) (Optional)**

The AV-30 has the option to connect to a third-party EFIS to synchronize data between the two. Data that can be synchronized includes heading bug, selected course, set altitude, set vertical speed, autopilot mode, CDI navigation source, altimeter setting, outside air temperature, and DG direction. At the time of publication of this pilot's guide, no third party EFIS supports this synchronization, though some integrations are in progress. Contact your EFIS vendor or uAvionix Customer Support for more information.

# 5 User Interface

## 5.1 Startup and Common Controls

The initial power-on splash screen presents the company logo, unit model number, and the currently installed software version.



Figure 4 – Splash Screen

Operation in AI, DG, MFD, and CDI modes share the following common user interface controls.

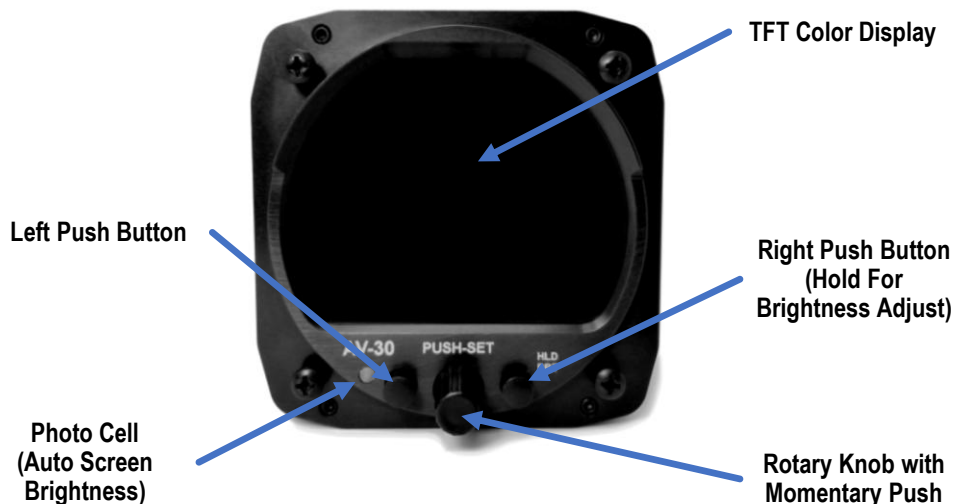

Figure 5 – Common User Interface Components

When installed as a non-required instrument (not replacing the existing approved AI or DG) and function lock is disabled, press and hold the center knob to switch between AI, DG, MFD, and CDI. If the Function Lock feature is enabled, then the pilot may not switch between modes. However, the DG can be switched into MFD (Traffic) mode. See *AV-30-E Installation Manual UAV1004234-001* for configuring the Function Lock feature.

## 5.2 “PUSH-SET” Control

Activate the PUSH-SET window for accessing context menus and settings by momentarily pushing and releasing the center knob.

This activates a window along the bottom of the display to allow various parameters to be adjusted with the center knob. Momentarily push and release the knob to scroll through each option.

When you reach the option to change, rotate the knob to scroll through all available values for this option. If the range setting has reached a limit, the left or right indication arrows will indicate which direction the center knob will change the setting. Both arrows are visible when the setting can be increased or decreased.

Momentarily push and release the knob to save the updated option value. The settings window will disappear, and the new setting is saved. In some cases where multiple settings are related, the window will stay open and advance to the next related setting.

The following options are available:

PUSH-SET Option	Description
SET BARO	Sets the barometer. Available if baro or altitude are displayed on screen.
DG ADJ	Adjusts the directional gyro. The DG should be compared against the compass heading and adjusted as necessary in flight. AV-Mag aiding reduces the need to adjust the DG.
HDG BUG / TRK BUG	A pilot-selectable heading bug, also used for autopilot modes. Displayed as heading bug when displaying a DG heading and track bug when displaying a GPS track.
OBS	Available only with AV-HSI. Omni-Bearing Selector can be set to Auto or to a manual bearing. When set to Auto, the AV-30 uses a bearing calculated by the GPS.
SRC SEL	Available only with AV-HSI. Sets the navigation source between GPS and VLOC.
SET ALT	The Set Altitude (SALT) used by an autopilot or as an overlay
SET VS	The Set Vertical Speed (SVS) used by RS-232 digital autopilots
AUTOPILOT	Sets the autopilot mode. Options are: <ul style="list-style-type: none"> <li>• Heading Bug (HDG BUG)</li> <li>• Track Bug (TRK BUG)</li> <li>• GPS Steering (GPSS) * available with Advanced autopilot software unlock. See Installation Manual for details.</li> <li>• Waypoint Desired Track (WPT DTRK)</li> <li>• Waypoint Bearing (WPT BRG)</li> </ul>



SQUAWK	Available if a BEACONX transponder is connected and squawk is displayed on screen. Sets the squawk code.
--------	--

## NOTICE

The parameters that can be adjusted will vary, based on the mode of the unit and the current configuration of the display. Figure 6 shows how the barometric setting is adjusted when altitude has been configured for display.



Figure 6 – Push-Set Example – SET BARO

When the “SET BARO” option holds a custom setting, it can be quickly reset to standard pressure, saving the current local setting. This allows the pilot to quickly switch between a local setting and standard pressure.

To reset to standard pressure, press and hold the center knob until the standard pressure value appears or press the right “STD” button. To swap back to the local setting, momentarily push and release the right “RECALL” button.

If using multiple AV-30s with an AV-HSI, push-set parameters can be synchronized between all AV-30s. For example, setting the heading bug on one AV-30 updates it on all connected AV-30s. The following parameters are synchronized.

- Heading Bug
- Selected Course/OBS
- Set Altitude
- Set Vertical Speed
- Autopilot Mode
- Nav Source Select

- Baro Setting
- Outside Air Temperature
- DG Heading Adjust

Synchronization of these parameters can be individually controlled. See the *AV-30-E Installation Manual UAV-1004234-001* for details.

### **5.3 Direct-Turn**

Commonly used parameters may be adjusted quickly by simply turning the center knob.

In AI mode, the barometric pressure setting is adjusted by simply turning the knob to bring up the 'SET BARO' window.

In DG mode, the heading bug is adjusted by simply turning the knob to bring up the 'HDG BUG' window. Note that direct turn of heading bug is disabled when using an autopilot mode that doesn't display the bug.

In MFD mode, the zoom range is adjusted by directly turning the knob. In CDI mode, the OBS is adjusted.

All adjusted values are active immediately. After adjustment, push and release the center knob to dismiss the window. If after 30 seconds the knob is not pressed, the window will be dismissed automatically.

### **5.4 User Interface Customization**

DG, AI, and CDI display modes are customizable to display data in a format and position on the screen according to pilot preference. Each display mode has multiple, customizable pages that the pilot may switch between during flight. Each page can be customized to show different sets of data. For example, AI page 1:3 (first of three) may be configured to show different types of air data, while page 2:3 (second of three) is configured to show Angle of Attack and Vertical trend, while page 3:3 (third of three) is configured to show GPS navigation waypoints and related data. The number of available pages is configurable in the Installation menu.



Figure 7 – Page 1 of 3 showing Air Data and DG Heading



Figure 8 – Page 2 of 3 showing GPS Ground Track, AoA, and Vertical Trend



Figure 9 – Page 3 of 3 showing Waypoint Data and SALT

Note that the fourth page is a simplified reversionary page and is not configurable. It only displays minimally required information.

## NOTICE

It is suggested that the display be customized prior to flight, and that each page be set up for the different basic modes of flight operations (Departure, En route, Terminal) prior to actual flight operations.

### 5.4.1 AI Mode Customization

Pressing the lower left options MENU button will bring up the first menu, which is the user interface customization menu. In this mode, the cursor can be moved to each customizable area by rotating the center knob.



Figure 10 – UI Customization, Menu Entry

The currently selected field will be indicated by a darkened block with a cyan bracket. Rotating the knob left and right will change the currently selected field. To edit the overlay value presented in the currently selected field, push and release the center knob then turn to change. Push and release the center knob to save the setting and finally, press DONE to close the menu.



Figure 11 – UI Customization - Field Selection

## 5.4.2 Edit Presented Data

The following shows the display when the edit mode is active. Rotating the knob left and right will then select from the various overlay values that can be presented in the selected field.

### NOTICE

When the desired data type is presented, pressing and releasing the knob will accept the current value, and the edit mode will remain active.

Press the DONE shown in the lower left button to accept the current value and exit the UI customization mode.



Figure 12 – Display Edit Value

Take note that not all data values can be presented in each editable field area. For example, airspeed will only be displayed on the left main area and altitude will only be displayed on the right side. Additionally, when operating in the DG mode, the available data displayed is different than when operating in the AI mode.

## 5.5 AI Mode Display Components

### 5.5.1 Basic Components

Figure 13 – Basic AI Mode User Interface shows the basic AI with all customizable data overlay fields turned off.

The data shown cannot be disabled or customized:



Figure 13 – Basic AI Mode User Interface

### 5.5.2 Customizable Data Overlay Fields

Figure 14 – AI Mode, Customizable Field Locations shows the locations of the inner and outer customizable fields when operating in the AI mode.

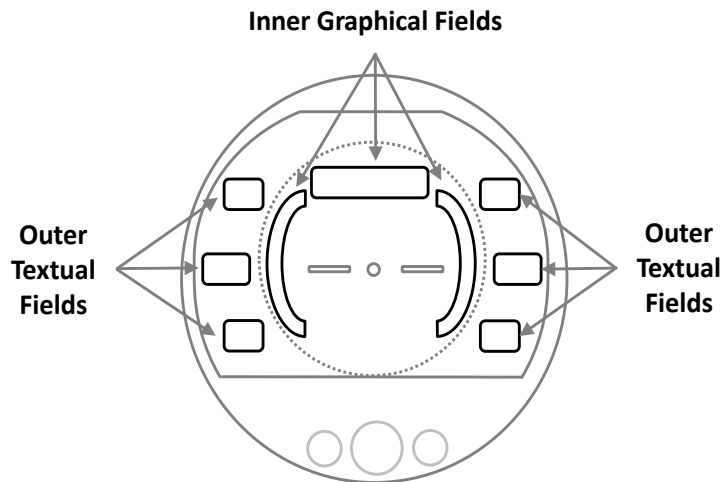

Figure 14 – AI Mode, Customizable Field Locations

There are three independent pages in the AI mode that may be configured as desired by the pilot. Unneeded pages may be disabled in the Installation Menu. Refer to *AV-30-E Installation Manual UAV-1004234-001* for installation menu information.

Figure 15 – Data Overlay Examples shows an example of the pilot customizable data overlays (both textual and graphical), located in the non-utilized areas of the display area.





Figure 15 – Data Overlay Examples

When in AI mode, there are three independently customizable pages which are selected round-robin fashion by momentarily pushing and releasing the right button repeatedly. The active page is displayed as 1:3, 2:3 and 3:3 on the lower right corner of the display.

A fourth, fully decluttered page allows all supplemental information to be hidden, leaving just attitude and slip displayed. This is accessed by momentarily pushing and releasing the right button a fourth time. Return to page 1 by momentarily pushing and releasing the right button.

### 5.5.3 Attitude / Slip

The basic display of attitude and slip consists of a traditional attitude indicator display and slip-ball as follows:



Figure 16 – AI Mode, Attitude Indicator



## NOTICE

On initial startup the red ALIGN flag will flash, indicating that the attitude is still stabilizing. Although this process mainly affects attitude display, this flag will appear on all pages and modes to ensure the proper function of the AI mode display and reversionary AI.

The aircraft should be held as motionless as possible during the alignment process.

If power is removed from the unit during the alignment phase the unit will remain on battery power until it has aligned.

When the ALIGN annunciator is displayed, the presented attitude may be incorrect. If ALIGN annunciator does not extinguish after 3 minutes, please contact uAvionix support.

Pitot and static data is used to aid the attitude algorithm. If pitot or static data becomes inaccurate due to ice or other obstructions, attitude accuracy may degrade. Increase vigilance in instrument cross scan.

---

### 5.5.4 Turn Coordinator

Two turn coordinator options can be configured for display near the top of the screen, a Rate of Turn indicator and a Standard Rate Bank Angle indicator. Configuration of this option is in the setup menu.



The Rate of Turn indicator consists of a flag that grows left or right from the Roll indicator. Alignment with the extended 30 degree roll mark indicates a 2-minute standard rate turn.

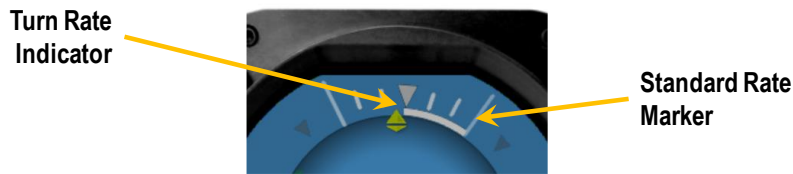

Figure 17 – AI Mode, Rate of Turn Indicator

The Standard Rate Bank Angle indicator consists of a small airplane shape that is positioned at the bank angle necessary to fly a standard rate turn at the current true airspeed. Because this indicator is dependent on true airspeed, an OAT probe is required.

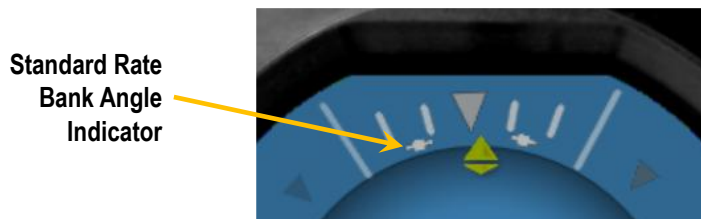

Figure 18 – AI Mode, Standard Rate Bank Angle Indicator

### 5.5.5 Airspeed Indicator

Indicated airspeed is configured for display on the left side of the screen. The configured units of knots (KTS), miles per hour (MPH), or kilometers per hour (KPH) are displayed below the speed value.



Figure 19 – AI Mode, IAS Indicator

The inner arc is a color-coded V-Speed band that rotates to show the configured V-Speed limits against the non-moving white tick mark. The lower arc portion below  $V_{s1}$  provides a red colored slow-speed band that is only displayed when the airspeed has been above  $V_{s1}$  for a given flight. If configured during installation,  $V_{MC}$  and  $V_{YSE}$  appear as red and blue radial tick marks, respectively.

The color of the indicated airspeed numerals will turn yellow when operating in the yellow speed arc, red when operating in a red speed arc, but are otherwise white.



Figure 20 – AI Mode, V-Speed Limits

## NOTICE

On initial startup, the airspeed field will display dashes while sensor stabilization occurs.

Airspeed display units and V-Speed limits are configured during installation and are not pilot accessible.

### 5.5.6 Flight Direction Indicator

The upper portion of the AI can be configured to display direction of flight in the form of either directional gyro heading (DG HDG) or GPS track (GPS TRK).

Both modes support a magenta heading bug (HDG BUG). If a GPS bearing is present a magenta bearing-to indicator will also be drawn. The heading bug may be used as a simple directional reference. In the case where the AV-30 is connected to an autopilot, the heading bug is used as the direction input to the autopilot (See §4.10).

If this field is configured to display GPS track, and no data from the GPS receiver is detected (e.g. it is powered off or disconnected), an amber “NO DATA” will be displayed. If a GPS is detected but it has not achieved a fix or is otherwise not providing useful data, “NO GPS” will be displayed.

If either the heading bug or the bearing-to bug are off the left or right sides of the screen, a colored arrow will show the shortest-turn direction to the corresponding bug. To quickly align the heading bug to the current heading, select HDG BUG, then push and hold the center knob.

Magnetometer aiding for DG heading is normally invisible to the pilot, however, there are two red warning flags that can occur. The first is “MAG CAL” which indicates a problem with the magnetometer calibration. The second is “NO MAG” which indicates that magnetometer sensor data is absent (e.g. connection failure). If either of these occur, refer to *AV-30-E Installation Manual UAV-1004234-001* for more information.



Figure 21 – AI Mode, Direction Indication, Bearing To Off-Screen

### 5.5.7 Barometric Corrected Altitude Indicator

Barometric corrected altitude (ALT) can be configured for display on the right side of the screen and shows the barometric altitude in feet. When this field is configured for altitude display, the lower right field will be locked to

the barometric setting and cannot be modified to display a different parameter.

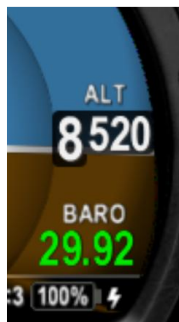

Figure 22 – AI Mode, Altitude Indicator

Adjust the barometric setting utilizing the center knob. See §5.2 - “PUSH-SET” for addition details.

Barometric setting in inches of mercury (INHG), millibars (MB), or hectopascals (HPA) are selected during installation and is not adjustable during ordinary operation.

## NOTICE

On initial startup, the field will display dashes while sensor stabilization occurs.

On unit power-down, the current field elevation and barometric pressure are stored in internal non-volatile memory. On the next power-up, the saved field elevation is used to compute an estimated barometric setting, potentially reducing the required adjustment amount required by the pilot. During this process, the barometric value will be shown in light grey.

### 5.5.8 AoA Indication

Derived Angle of Attack can be configured for display in the inner left area of the screen and consists of a series of colored stacked bars that indicates the current AoA relative to the configured minimum and maximum limits.

The lowest green bar corresponds to a current AoA matching the configured lower limit point. The first red bar corresponds to a current AoA matching the configured upper limit.

## NOTICE

AoA limit points are pilot selectable and are set in the Setup Menu

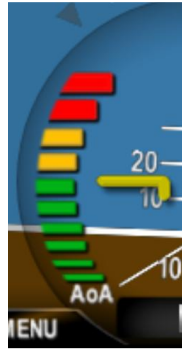

Figure 23 – AI Mode, AoA Indication

AoA is determined by the difference between the aircraft's pitch angle and the path through the air. See §9 - AoA Operation and Configuration for additional details on the AoA operation and setup.

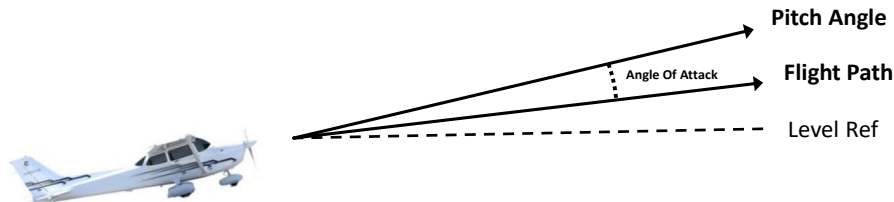

Figure 24 – AoA Computation

### 5.5.9 Vertical Trend Indicator

Vertical trend can be configured for display in the inner right area of the screen and consists of a white tick mark on a background scale. The upper and lower limits of the scale correspond to  $\pm 1000$  feet per minute.

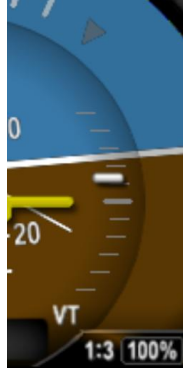

Figure 25 – AI Mode, Vertical Trend Indication

If the AV-30 is configured for an optional digital autopilot, the vertical trend indicator will display a magenta Set Vertical Speed (SVS) bug.



Figure 26 – AI Mode, Vertical Trend Indicator and SVS Bug

If the SVS bug is above or below the display limits of the vertical Trend indicator, a second magenta arrow will appear alongside the bug pointing up or down to indicate the SVS value is above or below the scale.

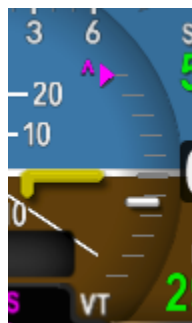

Figure 27 – SVS Bug value greater than scale

### 5.5.10 G-Load Indicator

The current G-Load can be configured for display on the inner right or inner left area of the screen and consists of a ball marker on a background scale. The upper and lower limits of the scale correspond to the upper and lower G limits set in the Setup Menu.



Figure 28 – AI Mode, G-Load Indication

The center most tick mark represents 1.0 G. Values above the center mark represent positive G, while those below represent less than 1.0 G levels. The scale markers will change color based on G limits set.

Horizontal bars indicate the maximum and minimum G load experienced. This is reset on power cycle or can be reset in the setup menu.

See §7 - Alerts and Alert Limits for additional information about G limit alerts.

### 5.5.11 Course Deviation and Glideslope Indicator

When connected with an AV-HSI, course deviation and glideslope from a GPS or VHF navigation source can be displayed on the AI.

These indicators can be enabled or disabled in the Setup Menu.





Figure 29 – AI Mode, Course Deviation and Glideslope Indication

When enabled, the course deviation indicator bar will always be present. The arrow points upward to indicate “TO” and downward to indicate “FROM.” Magenta is used to indicate the data is from a GPS source. Green is used to indicate the data is from a VHF nav source.



Figure 30 – AI Mode, ILS Course Deviation and Glideslope Indication

To declutter the screen, the glideslope indicator will only appear when vertical guidance is being provided by your navigator. Depending on your GPS navigator and approach type, this occurs at varying distances outside the final approach fix. Refer to your GPS navigator’s manual for details. For ILS approaches, the glideslope indicator will be present when a valid glideslope signal is received by your navigator.

If the screen location under the glideslope indicator was configured for vertical trend or G-load, those indicators will be suppressed while the glideslope is displayed.

When displaying GPS guidance and the GPS detects a Loss of Integrity, a yellow “GPS LOI” flag will appear above the lateral deviation bar. This indicates that the GPS data is not reliable and other means of navigation should be used.



Figure 31 – AI Mode, GPS LOI Indication

When approaching a waypoint, a gray “WPT” indicator will appear. Similarly, when the navigator has a message for the pilot, a gray “MSG” indicator will appear.



Figure 32 – AI Mode, Waypoint Indication

Navigation mode and approach type can be displayed on the AI using the “Nav Mode” overlay. See §5.7 AI / DG Displayable Parameters for details.

### 5.5.12 Text Fields

The four corners of the display screen can be configured to show various textual parameters. In this example, distance to waypoint, waypoint identifier, set altitude, and barometric pressure are displayed.



Figure 33 – AI Mode, Text Fields

## NOTICE

If a given parameter is invalid or currently unavailable, it will display dashes.

See §7.7 - AI / DG Displayable Parameters for the list of parameters that can be displayed in these fields.

### 5.5.13 Accessing Reversionary AI

A reversionary style display of attitude and slip is available as the fourth page in AI mode. Push and release the right button multiple times to engage this page. Push and release the right button again to return to the first (1:3) AI page. When connected to a transponder, this page provides control and monitoring of the transponder as detailed in §5.11. This reversionary page cannot be customized by the pilot.

## 5.6 DG Mode Display Components

### 5.6.1 DG Mode Customization

The DG customization mode is like the AI customization and the same methods are used to customize pages and fields.

The uppermost field selects the base direction indication. The options are a compass rose, Horizontal Situation Indicator (HSI), and ARC. Prior to software version 2.4.1, the rose display was limited to DG heading and the HSI and ARC display were limited to GPS Track. Software Version 2.4.1 enabled the option for each to be driven by DG heading or slaved to the GPS ground track.

DG mode has three customizable pages plus a reversionary AI page for transponder control.

### 5.6.2 Non-Slaved Heading Rose Mode

Figure 34 – Basic DG Rose Mode User Interface shows the non-slaved DG heading mode (HDG ROSE). Six textual fields are available for customization.



Figure 34 – Basic DG Rose Mode User Interface

Multiple aiding modes are available to assist with heading stability. That includes the use of an external magnetometer (AV-Mag). When configured for AV-Mag aiding, long-term heading stability will be excellent, but the device is still non-slaved, meaning the user can adjust the DG heading.

### 5.6.3 GPS-Slaved Heading Rose Mode

Provides the same compass rose presentation as Figure 34 – Basic DG Rose Mode User Interface, but is slaved to GPS Track instead of the DG.

### 5.6.4 Non-Slaved HSI Mode

When in non-slaved HSI (HDG HSI) mode, the outer compass ring displays DG heading while the center of the page shows GPS navigation data when connected to an external GPS navigator. GPS Navigation data is displayed in magenta.



Figure 35 – Non-Slaved DG HSI User Interface

If an AV-Mag is installed and configured, the DG heading is aided by the AV-Mag.

If the AV-30 is used with an optional AV-HSI and IFR capable navigator, vertical deviation will be displayed when valid vertical navigation signals are available from the navigator. To declutter the screen the vertical deviation bar is hidden when no vertical navigation data is available.

The Nav Mode indicator will display the current navigation mode. When the GPS is connected over RS-232, all navigation is VFR Only. When connected to an IFR capable navigator through an AV-HSI, IFR capable navigation is displayed. GPS Navigation mode options are as follows:

- VFR (1nm of error per dot of deflection)
- ENROUTE
- OCEANIC
- TERM (Terminal)
- APPR (Approach)

When in enroute, oceanic, and terminal mode, a TO/FROM indicator will be present on the right side of the nav mode indicator. When in approach

mode, the approach type will be displayed. Supported GPS approach types are:

- LP
- LNAV/VNAV
- LNAV
- LPV

Review your GPS manual for mode definitions.

When connected with an AV-HSI and a VHF navigator, VHF Nav guidance can be selected in the PUSH-SET menu by setting NAV SRC to VLOC.



Figure 36 – Non-Slaved DG HSI User Interface with VOR Guidance

The Nav Mode indicator will display the current navigation mode. When a VHF navigator is connected to the AV-HSI, supported modes are:

- ILS (Instrument Landing System)
- LOC (Localizer)
- VOR (VHF Omnidirectional Range)

When receiving a VOR signal, TO/FROM is indicated in the right side of the Nav Mode Indicator as well as by the arrow on the course deviation bar. This arrow will be on the “pointer” side of the bar to indicate TO. The arrow



will be on the “tail” side of the bar to indicate FROM. When displaying VOR, each dot of deflection equals 5 degrees of course.

No TO/FROM indication is available when tuned to an ILS or Localizer. A glideslope indication is automatically displayed when available on an ILS approach.

### 5.6.5 GPS-Slaved HSI Mode

The GPS-slaved HSI (GPS HSI) mode uses the same HSI presentation the non-slaved HSI mode but the compass ring is slaved to GPS Track instead of the DG.

This mode is particularly useful when tracking a course because it does not require the pilot to compensate for wind drift.



Figure 37 – GPS-Slaved HSI Mode with VFR GPS

### 5.6.6 Non-Slaved ARC Mode

The display type can also be configured to show the current GPS flight plan in a map style presentation. In the non-slaved (DG ARC) mode the outer compass ring displays the DG heading while the center of the page shows the GPS flight plan, if connected to a GPS navigator.

As depicted in Figure 39 – Arc Mode with Holding Pattern the active leg is highlighted in magenta. Subsequent legs are gray.

Note: Software version 2.4.1 and newer display a full flight. Software versions 2.3.9 and prior display only the active leg and only allow the GPS-slaved ARC Mode.

The display scale is adjusted by rotating the center knob and represents the display distance from the ownship icon to the outer compass ring. The following scales may be selected for display:

**Selectable Display Scales:  
1, 2, 5, 10, 20, 50 and 100 nm**

**NOTICE**

GPS flight plan depiction is for advisory use only. Navigating by the moving map alone is not sufficient for IFR operations.



Figure 38 – Arc Mode with Course Deviation and Glideslope

If connected to an AV-HSI and ARINC 429 navigator, IFR lateral and vertical guidance can be overlaid on the ARC display. They are enabled or disabled in the Setup menu. The Course Deviation and Glideslope deviation bars can be used for approach guidance. The moving map itself is for VFR advisory use only.

If connected with an AV-HSI and GPS navigator that supports GAMA flight plan exchange, the ARC display will depict holding patterns and DME arcs.





Figure 39 – Arc Mode with Holding Pattern

### 5.6.7 GPS ARC Mode

The GPS-slaved ARC (GPS ARC) mode uses the same ARC presentation as described in the prior section, but the compass ring is slaved to GPS Track instead of the DG.



Figure 40 – Arc Mode without Course Deviation and Glideslope

### 5.6.8 Operational Aspects

The following applies to operation in DG mode.

- As with the AI mode, three customizable pages can be setup by the pilot. Each page can be configured to show any of the above six display modes.
- Non-Slaved modes require the pilot to set the initial heading and correct the heading as required based on the compass. The system will initialize to the last set heading on shutdown, except when an AV-Mag external magnetometer is installed. Refer to *AV-30-E Installation Manual UAV-1004234-001* for information regarding the AV-Mag calibration procedure.
- In Non-Slaved modes, the PUSH-SET menu brings up the DG ADJ entry on the first push of the center knob. However, if an AV-Mag is installed, HDG BUG will appear first and DG ADJ will be last.
- A pilot entered DG adjustment value can be cleared by entering the PUSH-SET menu, advancing to DG ADJ, then pushing and holding the center knob for 2 seconds. The heading will snap to the value indicated by the AV-Mag and the user entered adjustment will be set to zero. Note that this only applies when the AV-Mag is installed.
- If magnetometer aiding is configured but calibration is not complete the “MAG CAL” flag is indicated. If the AV-30 is not receiving the magnetometer sensor data (e.g. connection failure), the “NO MAG” flag is indicated.
- Air data / temperature related parameters (TAS, DALT, OAT) are only available if an OAT is present. If multiple AV-30s are connected to an AV-HSI, only one AV-30 is required to have an OAT probe.
- The currently displayed GPS track may optionally be gyroscopically stabilized, allowing smoother operation when in turns. This option is configured in the Setup Menu (GPS Track Stabilization).
- When GPS Track is the base direction, any GPS error conditions that might occur are indicated according to Table 1 – GPS Error Messages.

GPS Error Message	Meaning
NO DATA	No data/messages are being received over the serial port.
NO GPS	No GPS Fix or some other condition is preventing the GPS receiver from providing useful data.
NO COURSE	No waypoint navigation information has been received yet. This message is suppressed when BeaconX is the primary GPS. Displayed on HSI page.
NO BEARING	No waypoint navigation information has been received yet. Displayed on ARC page.

Table 1 – GPS Error Messages

### **5.6.9 Accessing Reversionary AI**

A reversionary style display of attitude and slip is available in DG Mode. Push and release the right button multiple times to engage this page. Push and release the right button again to disengage. When a transponder is connected, this page also allows control and monitoring of the transponder as detailed in §5.11.

The Reversionary AI page cannot be customized by the pilot.

## **5.7 AI / DG Displayable Parameters**

The following table shows which data fields can be displayed when operating in AI and DG modes.

The 'Graphical' presentation type indicates that the data is displayed in a graphical format (dial, tape, bug, etc.). The 'Textual' presentation type indicates that the data is displayed in text.

Data Type	Presentation	AI Mode	DG Mode	CDI Mode
Blank Overlay Field	N/A	✓	✓	✓
Attitude	Graphical	✓	✓	✓
Non-Slaved Heading	Graphical	✓	✓	✗
Non-Slaved Heading	Textual	✓	✓	✓
Bus Voltage	Textual	✓	✓	✓
G Load Value	Textual	✓	✓	✓
G Load Max	Textual	✓	✓	✓
G Load Min	Textual	✓	✓	✓
G Load Indicator	Graphical	✓	✗	✗
Indicated Airspeed <sup>(1)</sup>	Textual	✓	✗	✗
Barometric Corrected Altitude <sup>(2)</sup>	Textual	✓	✓	✓
Barometer Setting <sup>(3)</sup>	Textual	✓	✓	✓
Angle of Attack	Graphical	✓	✗	✗
Vertical Trend Indicator	Graphical	✓	✗	✗
Vertical Speed	Textual	✓	✓	✓
Set Altitude	Textual	✓	✓	✓
Set Vertical Speed Bug <sup>(4)</sup>	Graphical	✓	✗	✗
Outside Air Temp <sup>(5)</sup>	Textual	✓	✓	✓
True Airspeed <sup>(5)</sup>	Textual	✓	✓	✓
Density Altitude <sup>(5)</sup>	Textual	✓	✓	✓
Direction Tape	Graphical	✓	✗	✗
Direction Rose	Graphical	✗	✓	✗
Direction ARC <sup>(6)</sup>	Graphical	✗	✓	✗
Direction HSI <sup>(6)</sup>	Graphical	✗	✓	✗
GPS Navigator Data <sup>(6)</sup>	Textual	✓	✓	✓
GPS HSI Indicator <sup>(6)</sup>	Graphical	✗	✓	✗
GPS Navigator Route <sup>(6)</sup>	Graphical	✗	✓	✗
Heading Bug	Graphical	✓	✓	✗
Carbon Monoxide <sup>(7)</sup>	Textual	✓	✓	✓
Nav Mode <sup>(6)</sup>	Textual	✓	✓	✓
AP Mode <sup>(8)</sup>	Textual	✓	✓	✓
OBS <sup>(9)</sup>	Textual	✓	✓	✓
SQUAWK <sup>(10)</sup>	Textual	✓	✓	✓
Climb (ft/nm) <sup>(6)</sup>	Textual	✓	✓	✓

Table 2 – Data Overlay Types vs Operational Mode

- (1) Only available in the middle-left overlay location
- (2) Only available in middle-right overlay location
- (3) Only available in lower-right overlay location
- (4) Only available when Autopilot is installed and Vertical Trend Indicator is visible
- (5) Only available when OAT sensor is installed
- (6) Only available when a GPS navigator is installed
- (7) Available when a Sentry ADS-B receiver is connected to an AV-Link
- (8) Only available when Autopilot is installed

- (9) Only available when AV-HSI is installed
- (10) Only available when BEACONX is installed

### 5.7.1 Bus Voltage Threshold

Bus Voltage (BUSV) is a textual overlay available on AI, DG, and CDI pages. Starting with software version 3.0.0, alerting thresholds can be set in the Setup Menu (See §10) to alert the pilot of an alternator failure or over-voltage condition. When BUSV is outside these thresholds the BUSV color changes to red to alert the pilot of the condition.



Figure 41 – BUSV Threshold Setup

### 5.7.2 G-Min and G-Max Reset

Starting with software version 3.0.0, the AV-30 can display the maximum and minimum G-Load as a textual overlay and on the G-Load graphical overlay.

G-Min and G-Max automatically reset on power cycle and can be manually reset in the Setup Menu (See §10).

## 5.8 MFD Mode

When equipped, the AV-30 can display real-time traffic data. To enable the MFD mode, SERIAL 3 must be set to 'AVLINK'. See *AV-30-E Installation Manual UAV-1004234-001* on how to set SERIAL 3.

To view the MFD mode, long press of the center knob to bring up each of the mode screens in sequence: AI, DG, MFD, and CDI (if equipped with AV-HSI). If the AV-30 is function locked to DG, a long press of the center knob to bring up the MFD mode but note that MFD is not available on AI function locked units.

This page will display traffic (left example in Figure 42) only when AV-Link is properly connected to the AV-30. If configured but not properly connected, the words “NO DATA” will be displayed in the bottom-left corner of the screen (see the right photo in Figure 42).



Figure 42 – AV-30 Traffic Page

## NOTICE

The AV-Link accessory is not powered by the AV-30 internal battery. Wi-Fi traffic data provided to the MFD mode will be unavailable during a power loss.

In installations with multiple AV-Links installed on multiple AV-30s, SERIAL 3 should only be set to AVLINK on the single AV-30 that is intended to be used as a traffic display. Any AV-30 with SERIAL 3 set to AVLINK will continuously communicate with the ADS-B receiver in the background even if the MFD mode is not active. Limiting MFD to just one AV-30 reduces congestion of the aircraft’s Wi-Fi network.

### 5.8.1 Features

When AV-Link is installed and configured to connect to a Wi-Fi capable ADS-B receiver both airborne and ground traffic display are available.

Only Wi-Fi capable ADS-B receivers are supported. Bluetooth enabled ADS-B receivers are not supported.

ADS-B Wi-Fi receivers that have been confirmed as compatible include:

- Sentry
- Sentry Mini
- skyEcho2
- skySensor
- echoUAT
- Stratus 3 (in Open GDL Mode only)
- Dynon Avionics DRX
- Level Aviation iLevel 3 AW
- BOM, iLevel 3 SW, and Astro Link should work
- SkyGuardTWX
- Stratux
- Falken Avionics FlightBox

This is not an exhaustive list.

Some of these receivers will require setting the AV-Link to a custom port value if the ADS-B receiver transmits GDL90 information on a port other than 4000 (default).

More receivers may be compatible using the AV-Link ADS-B Wi-Fi settings custom port setting. See §11.5.1 - ADS-B Receiver Settings to configure the AV-Link custom port setting.

### **5.8.2 Firmware Update**

After the AV-Link and AV-30 have been installed, a firmware update may be required to enable the AV-Link features of the AV-30. See *AV-30-E Installation Manual UAV1004234-001* for instructions on installing firmware. A minimum software version of 2.0.0 is required to support MFD Mode.

After the update, the AV-30 MFD mode will display the words “NO DATA” until an attached AV-Link is installed, powered, and connected to your ADS-B receiver.

See §11.5.1 - ADS-B Receiver Settings for guidance for updating AV-Link and connecting to traffic sources.



### 5.8.3 Display Functions

The MFD requires ownship GPS information to display the relative positions of nearby traffic. This GPS information can come from the connected ADS-B receiver, the AV-30's connected GPS navigator, or traffic targets with an ICAO address matching the configured ownship ICAO (see §5.8.9.1).

In addition to displaying "NO DATA" when the AV-Link is not properly connected, the bottom left corner of the screen may show one of the following messages to describe the status of the MFD's position source, listed in order of descending severity and display priority:

- NO DATA – AV-Link is not connected or is not functioning.
- NO GPS SRC – None of the possible GPS sources are connected or sending position information.
- NO GPS FIX – None of the possible GPS sources have a valid GPS fix.
- NO ALTITUDE – Both barometric and GPS altitude are unavailable. Target relative altitude is unavailable.
- NO GPS HDG – Neither track nor heading are available. The display will default to a north-up orientation.

When "NO GPS SRC" or "NO GPS FIX" are displayed, a traffic count shall be displayed in the bottom right corner of the screen to warn about nearby traffic targets even when they cannot be displayed on screen.

Traffic displays, both airborne and ground, are available. Traffic is represented by a chevron icon, pointing in the direction of travel. Traffic on the ground is colored brown and traffic in the air is colored cyan.

Traffic that has no heading is classified as an airborne obstacle and is represented by a cyan diamond icon.

In normal monitor mode, the screen will display active traffic and has a zoom function to permit the pilot to view traffic from 1 nautical mile (nm) to 40 nautical mile range. Due to the placement of the ownship icon, more distance is displayed forward of ownship than behind.

Concentric rings display hints on distance. There are three in total. Depending on the range selected, these represent the 1/3, 2/3 and full display distance. Each are marked with the current range distance. For



example, at 1 nautical mile range setting, the rings are set at 0.33 nm, 0.66 nm, and nm.



Figure 43 – Traffic Display

### 5.8.4 Display Zoom

Target detail will vary based on the current zoom level. This is to reduce visual clutter. As zoom is set to closer distances, extra target information will be placed next to the target icon. These include relative altitude to ownship and the speed vector extending from the front of the target.



Figure 44 – Traffic Display Zoom

**Selectable Display Scales:  
1, 2, 5, 10, 15, 20, 30 and 40 NM**

### 5.8.5 Target Relative Altitude

Relative altitude is determined using real-time altitude information from ownship as well as each individual target. It is possible to have two types of altitude information: pressure altitude and geometric altitude.

In compliance with DO-317C §2.3.5.15.1, the target relative altitude is calculated by either (1) using the pressure altitude of both aircraft or (2) if valid pressure altitude is unavailable, by using the geometric altitude of both aircraft. The relative altitude shown for a target is positive when the target is higher than ownship and negative when the target is lower than ownship. If the same altitude type is not available for both ownship and the target, then no relative altitude is displayed for that target.

Note: AV-30 must be connected to aircraft pitot and static pneumatic connections for correct relative altitudes to be displayed.



Figure 45 – Traffic Target Relative Altitude

Some uncertified advisory display systems will use a combination of pressure altitude and geometric altitude for the calculation of the target relative altitude. This is not in compliance with DO-317C §2.3.5.15.1 and therefore may result in a difference between the relative altitude displayed on the AV-30 and the other system.

Relative altitude is displayed in units of hundreds of feet. For example, a display of +335 indicates that the target is 33,500 feet above ownship. The “+” indicates the target is above ownship and the label is placed *above* the target icon. If the target is below ownship, then a “-” value is used, and the label is placed *below* the target icon.

## 5.8.6 Target Airspeed

Target airspeed is indicated by a vector line extending from the front of the target. A longer vector indicates that the target airspeed is faster than a different target with a shorter vector. This vector is visible only when the zoom range is 20 nautical miles or closer.

Activate the target tracking function to see the target's numerical airspeed and other details.

## 5.8.7 Target Tracking Function

Momentarily push and release the center knob to activate the target tracking function. Rotate the center knob to select the target to track. Information details about the target will appear at the top of the display. This information includes callsign or flight plan identifier, information source, type of aircraft, distance, altitude, and airspeed. If an information item is unavailable, then dashes "---" will appear for the item.

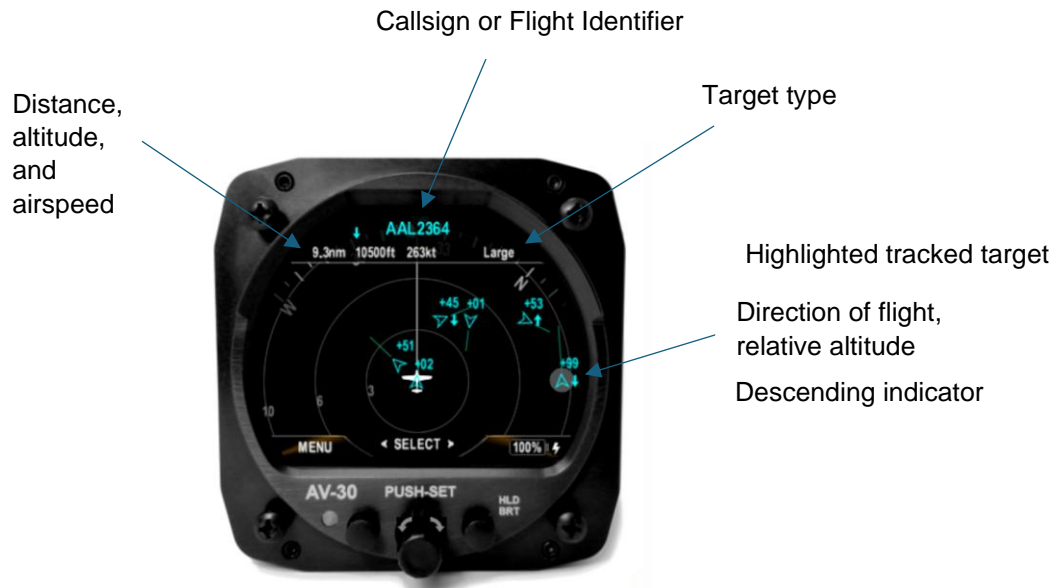

Figure 46 – Traffic Target Tracking Function

The screen will stay in tracking mode until disengaged with a push and release of the center knob. During tracking, the zoom function is disabled.

### 5.8.8 Accessing Reversionary AI

A reversionary style display of attitude and slip is available from the traffic page. Push and release the right button to engage this mode. Push and release the right button again to disengage.



Figure 47 – Traffic Reversionary AI Activation

When a transponder is connected, this page also allows control and monitoring of the transponder as detailed in §5.11. This mode page cannot be customized by the pilot.

### 5.8.9 Traffic Mode Configuration

The traffic mode has settings that can be configured for ownship identity, to prevent the ownship from being displayed as “ghost” aircraft, and traffic filtering for reducing the content displayed on the screen.

#### 5.8.9.1 Ownship ICAO

If your aircraft is not equipped with an ADS-B Out system, Air Traffic Control (ATC) can rebroadcast your Mode C target to nearby aircraft using Traffic Information Service – Broadcast (TIS-B). TIS-B is a service that relays information derived from basic transponder equipped aircraft observed by Secondary Surveillance Radar (SSR) to ADS-B In equipped aircraft.

If you receive that transmission, it can cause your own aircraft to be displayed as a nearby target, usually slightly behind you and  $\pm 100$  to 200

feet in altitude, from the slight delay in the transmission reaching you due to the secondary surveillance radar processing and rebroadcasting delay.

Every ADS-B In system occasionally displays a ghost, even for those aircraft equipped with ADS-B Out. Entering your ownship ICAO can remove that identified ghost from the traffic screen.

Ownship ICAO can be entered manually using the OWNSHIP ICAO menu entry. Once entered, the value is saved but can be changed at any time.

If a uAvionix transponder is installed and transponder control is enabled, ownship is automatically detected and entered for you on this screen. Manual override of this value is not permitted when transponder control is enabled.

Finally, because the MFD mode requires a GPS source to draw the relative positions of nearby traffic, entering your ownship ICAO can allow the MFD mode to continue functioning even in the event of a GPS signal loss by your onboard GPS and ADS-B In systems. When configured with your ownship ICAO, when the AV-30 receives traffic data for your aircraft via ADS-B, ADS-R, or other sources, the MFD mode will use those traffic reports as a fallback GPS data source.



### 5.8.9.2 Traffic Filtering

Traffic can be filtered by ownship relative altitude to reduce the information displayed on the screen. Ownship altitude is collected from one of multiple sources: ownship reports, GPS altitude, ownship barometric altitude.



Traffic filter selection options are Normal, Above, Below, Only Own and None. Full descriptions of each of these are found in Table 3 – MFD Configuration Options.



Figure 48 – Examples of Alternate Filter Values

Setting	Options	Description
Filter	Normal	Filter ownship, traffic above and below 2700 feet relative to ownship
	Above	Filter ownship, traffic above 8700 feet and below 2700 feet relative to ownship
	Below	Filter ownship, traffic above 2700 feet and below 8700 feet relative to ownship
	Only Own	Filter only ownship
	None	Displays all traffic
Ownship ICAO	Dependent on registration number	Press and release, then rotate center knob to select each number or letter associated with aircraft ICAO. This will allow for ownship filtering.
VSI	DISABLED, ENABLED	Overlay a vertical speed indicator on the MFD.

Table 3 – MFD Configuration Options

### 5.8.9.3 Vertical Speed Overlay

Some pilots may wish to have a dedicated traffic display but do not have an extra instrument hole available. A vertical speed indicator overlay is available on the MFD page to allow an AV-30 to replace a vertical speed indicator. This indicator will graphically display to +/- 1,000 ft/minute. The numeric indicator will display up to 9,999 ft/minute.



Figure 49 – MFD with VSI Overlay

## 5.9 CDI Mode

When equipped with an AV-HSI, the AV-30 can display a traditional Course Deviation Indicator. This mode is accessible when the AV-30 when the function lock on the AV-30 is not set. To cycle through modes to the CDI mode, press and hold the center knob.

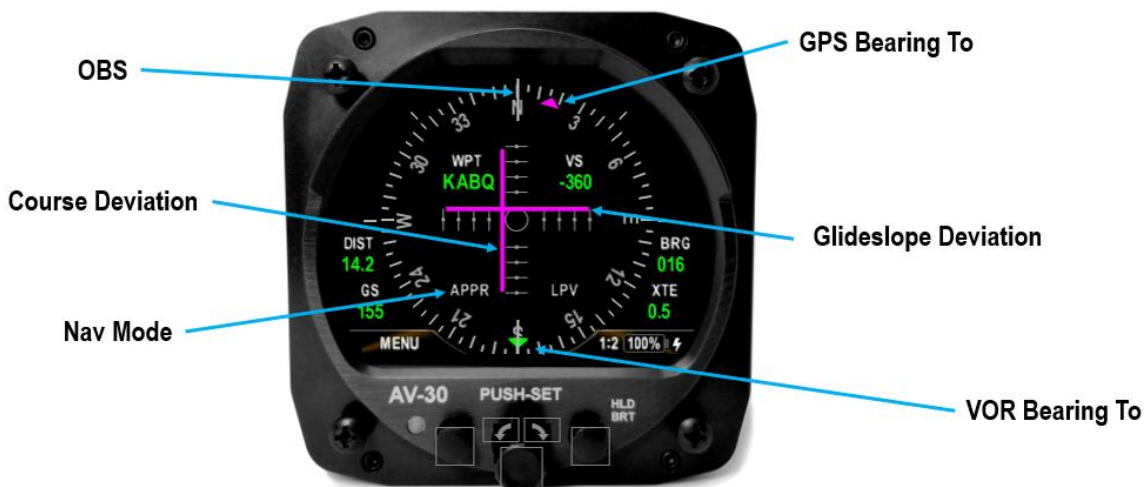

Figure 50 – CDI Mode with GPS Guidance



The CDI mode can display lateral and vertical guidance for GPS or VHF navigators. Changing navigation source and OBS is done in the PUSH-SET menu.

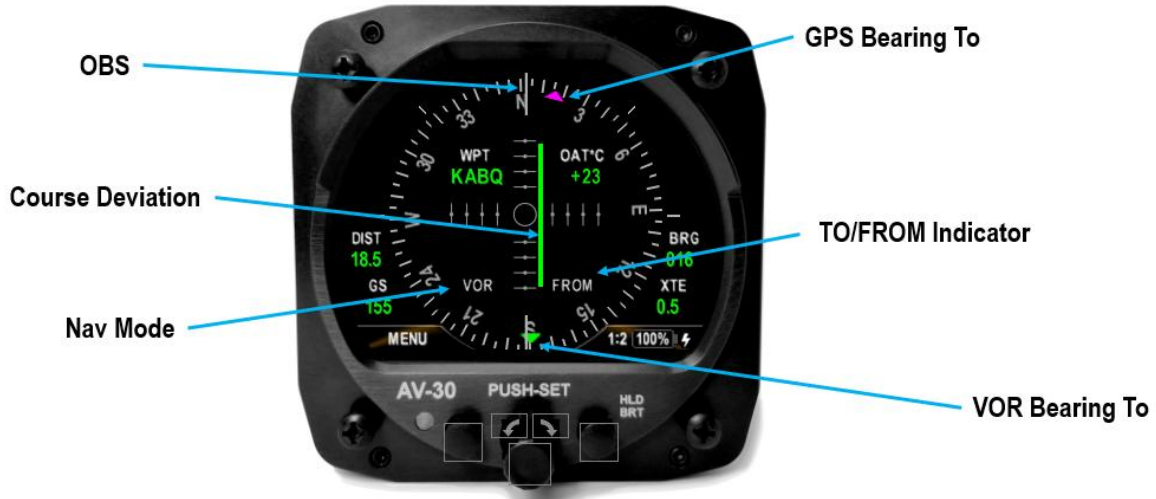

Figure 51 – CDI Mode with VOR Guidance

Like the DG HSI mode, a gray “MSG” and “WPT” indicator will appear when the GPS has a message for the pilot and when approaching a waypoint, respectively.

There are six configurable overlay positions available on the CDI. The CDI includes two independent pages and a reversionary AI.

## 5.10 Reversionary AI



Figure 52 – Reversionary Attitude Indicator



The Reversionary AI page is the last page in all operating modes. It presents a reversionary style display of attitude and slip. When a transponder is connected, this page also allows control and monitoring of the transponder. This mode page cannot be customized by the pilot, but the transponder control can. See §5.11 - Transponder Control for details on transponder control.

## 5.11 Transponder Control

When installed and configured, the AV-30 can be used to control select uAvionix transponders (including the BeaconX family). The full set of transponder controls are available on the Reversionary AI page. Squawk and Ident can be controlled on pages other than Reversionary AI.

### 5.11.1 Reversionary AI Transponder Control

The reversionary AI page is accessed by pressing and releasing the right button repeatedly until AI appears in lower right corner of the display.

#### 5.11.1.1 Status

The transponder control user interface, as presented on the reversionary AI page, is shown below.

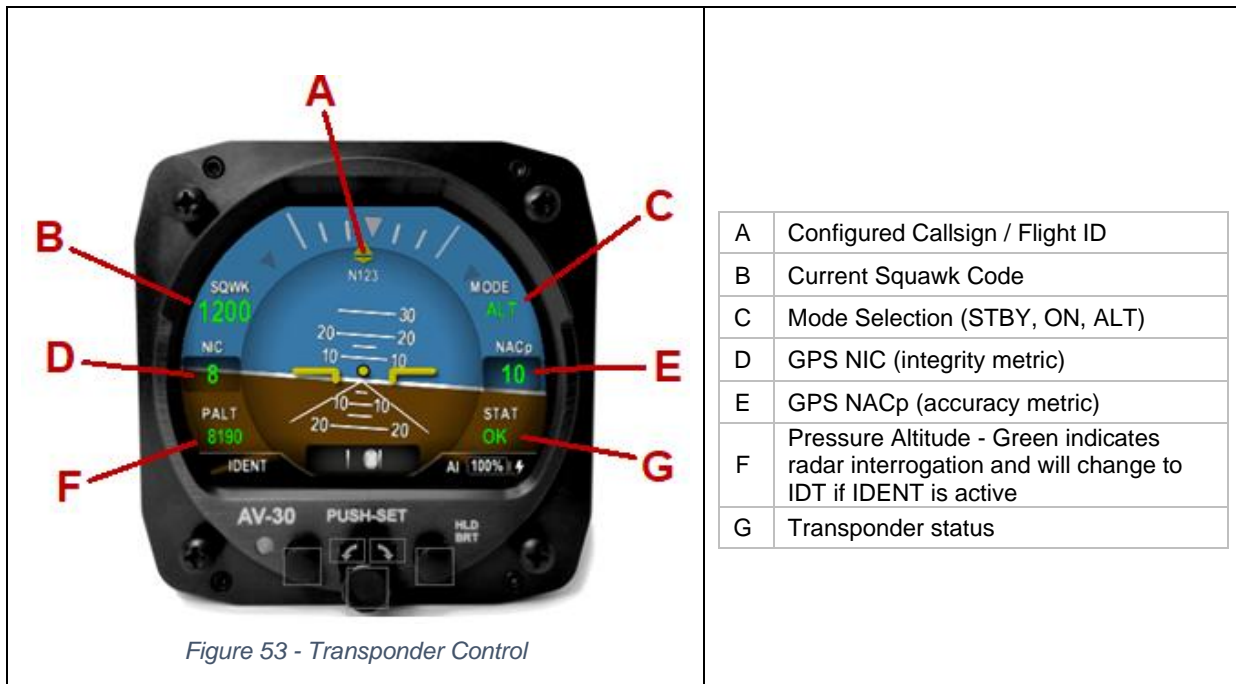

The current transponder status is indicated by the STAT field. The following status annunciations may be displayed.

Status	Description
OK	Status good, no fault
NOPOS	No GNSS position information, ensure clear sky view
FAIL	Transponder device failure (broadcast monitor or transmission system)
TMOUT	Timeout, unable to communicate with transponder
MAINT	Maintenance required, ensure proper configuration (e.g. ICAO address)
WAIT	Retrieving configuration from transponder
FAULT	Unknown or generic fault
XPRST	Transponder reset. Maintenance required, ensure proper power connections to tailBeaconX.

Table 4 – Transponder Status

### 5.11.1.2 Changing Squawk

1. Press and release the center knob to bring up the squawk edit menu. The first digit of the squawk will be highlighted.
2. Rotate the center knob to change the highlighted squawk digit.
3. Press and release the center knob to move the highlight to the next squawk digit.
4. Repeat steps 2 and 3 until the desired squawk code has been set. The squawk edit menu will close after pressing and releasing the center knob while the last digit is highlighted or by pressing the left “Done” button.

**i** Press and release the right button to quickly set the Squawk to 1200 (or an alternative VFR value if one is programmed into the BeaconX).



### 5.11.1.3 Changing Flight ID

1. Press and release the center knob to open the squawk edit menu.
2. Push and hold the center knob until FLIGHT ID appears. The first character of the flight ID will be highlighted.
3. Rotate center knob to change the highlighted character.
4. When desired character appears, push the center knob to accept it and highlight the next character.
5. Repeat steps 3 and 4 until the desired flight ID is set.
6. Push and release the right button (CLEAR) at any time to clear the Flight ID completely.
7. Press and release the left button (DONE) to close the flight ID edit menu and save the setting.



*No spaces are permitted in the FLIGHT ID. The highlighted character must not be blank to advance to the next character.*

### 5.11.1.4 Changing Transponder Mode

1. Press and release the center knob to open the squawk edit menu.
2. Press and hold the right button to cycle between 'VFR' and 'MODE'.



3. With 'MODE' highlighted, a single press and release of the right button will cycle through each mode selection. (STBY, ON, ALT)
4. Press the left 'Done' button to close the menu.

### 5.11.1.5 To Send IDENT

To trigger transponder IDENT:

1. If in Reversionary AI, press and release the left button, labeled IDENT. IDT will be displayed green in the lower left of the screen to indicate that IDENT is active.

2. If on other pages displaying squawk, press and release the center knob until SQUAWK is displayed in the PUSH SET Menu. Press the right button, labeled IDENT. The IDENT text will change from white to green to indicate that IDENT is active.

#### 5.11.1.6 Quick Squawk VFR

The VFR squawk code is stored in the BeaconX transponder. By default, this is set to 1200 for U.S. operations but may be set to another value via a separate transponder configuration application. See *tailBeaconX TSO User and Installation Guide UAV-1004270-001* for details.

The quick way to change the squawk code to VFR is:

1. Press and release the center knob to open the squawk edit menu.
2. In Reversionary AI, press and release the right button labeled VFR. In all other pages, press and hold the center knob.

#### 5.11.2 Squawk Overlay

The current squawk code can be displayed on screen for AI, DG, and CDI modes. See §5.4 for guidance on configuring overlay fields.

To change squawk on non-Reversionary AI pages, open the PUSH-SET menu and cycle through to SQUAWK. To send IDENT, push and release the right button while in the squawk edit menu. Pressing and holding the center knob will set squawk to the VFR value.



Figure 54 - Squawk Overlay Push-Set Menu

## 5.12 Brightness Menu

Brightness adjustment is quickly accessed using the button labeled HLD BRT on the case. The brightness menu is activated by pressing and holding the lower right button until the brightness option appears.



Figure 55 - Brightness Menu

The MODE button toggles between AUTO BRT (automatic brightness mode), and MANUAL BRT (manual brightness mode). Automatic brightness mode is the default setting on power up.

When in manual brightness mode, rotate the center knob to adjust brightness from 1 to 100. When in automatic brightness mode, the AV-30 automatically adjusts the screen brightness to match ambient light levels detected by the bezel-mounted photocell in the lower left.

Press DONE to exit the menu.

## 6 User Interface and Font Style Options

Three different cosmetic styles and two different fonts are selectable by the pilot. The three UI styles are LEGACY, EFIS and VINTAGE. The two font selections are ARIAL and LCD.



Figure 56 – UI Style Options

These settings only affect the displayed colors and font style – all functional operations are identical regardless of style settings.

## 7 Alerts and Alert Limits

The AV-30 supports flight envelope, altitude, and carbon monoxide alerts when configured accordingly.

### 7.1 Airframe Envelope Alerts

Flight envelope alerts provide both visual and aural alerts on the AI mode only.

There are three airframe envelope alert types.

- Excessive Bank Angle Alerts.
- Excessive G-Load Limit Alerts.
- Excessive Angle of Attack (AoA) Limit Alerts.et

Figure 57 shows an example how the visual alerts are displayed.



Figure 57 – Example of Alert Annunciator on Screen

The priority and warning / alert levels, from the lowest priority to the highest priority are found in Table 1Table 5.



Type	Priority	Percent	Aural	Visual
Roll	7	100%	“Roll”	ROLL
AoA	6	80%	One Tone	ANGLE
AoA	5	90%	Two Tones	ANGLE
AoA	4	100%	“Check Angle”	ANGLE
G Limit	3	80%	One Tone	G LIMIT
G Limit	2	90%	Two Tones	G LIMIT
G Limit	1	100%	“G Limit”	G LIMIT

Table 5 – Envelope Alert Types and Priorities

The thresholds for each alert are pilot adjustable, and each alert type can be independently enabled or disabled.

## NOTICE

Pressing the center knob when an alert is active will clear alert.

### 7.2 Altitude Alert

The Set Altitude alert is a visual alert only. It is signaled by the Set Altitude text display changing from white to green. Green indicates that the barometric corrected altitude is within  $\pm 100'$  of the Set Altitude.

### 7.3 Carbon Monoxide Alert

When configured with an AV-Link and a Sentry ADS-B receiver, the AV-30 will display Carbon Monoxide status and alerts.

Carbon Monoxide (CO) Status is an overlay that is pilot selectable. It will display “OK” for CO levels below 75ppm. At CO Levels between greater than or equal to 75ppm the numerical level will be displayed in yellow. At CO levels greater or equal to 200ppm the numerical level will be displayed



in red and a red alert will appear in the center of the AI. This alert may be dismissed by pressing the center knob.

The CO alert will trigger even if CO is not currently displayed as an overlay. The CO alert is not user configurable.

## 7.4 Attitude Miscompare Alert

When multiple AV-30s are connected to an AV-HSI, the AV-HSI continuously compares the attitude solution on each AV-30 and will alert the pilot if the attitude solutions disagree by more than 8 degrees of pitch or 8 degrees of roll.

This case will be annunciated on the AI with an alert “CHK ATTITUDE” and an audible double beep.



This alert informs the pilot that the attitude solution may not be correct and that they should maintain a diligent cross-scan and use partial-panel techniques or visual reference to conclude the flight.

Nuisance alerts may require gyro calibration. See the *AV-30-E Installation Manual UAV-1004234-001* for details. This alert may be disabled in the Installation Menu under the State Sync submenu.

# 8 Internal Battery Operation

## 8.1 General

The internal battery consists of a rechargeable battery system with automatic recharge, self-test, and power switching capability. The internal battery capacity will provide approximately 2 hours of operation at standard temperatures and 30 minutes (minimum) of operational capacity over the operational temperature range.

## 8.2 Battery Transition Logic

The AV-30 uses airspeed and aircraft bus voltage to manage the battery system.

### 8.2.1 Power-On Self-Test (Pre-Flight)

On powerup, the battery charge status will show “TEST” in amber. During this process, an internal load is applied to the battery to determine general capacity capability. If the battery fails this self-test, the charge status field will show “FAIL” in red, and no battery capability will be available.

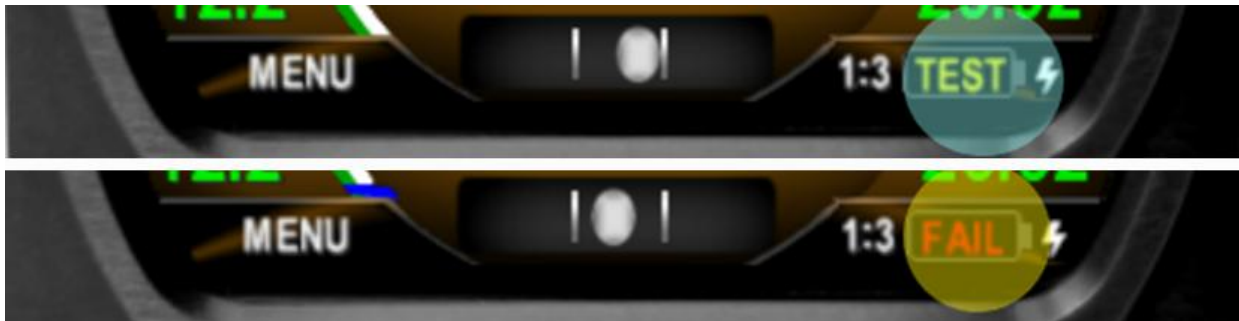

Figure 58 – Battery Test Indicators

### NOTICE

If the battery status shows “FAIL,” departure into actual or planned IFR conditions must not be performed.

## 8.2.2 Power Loss, Airspeed Above 40 Knots (In-Flight)

When in flight and the bus voltage drops below 7 VDC, the unit will automatically transition to internal battery operation; no pilot action is required for continued operation.

The “ON BATTERY” annunciation will be displayed:



Figure 59 – On Battery Operation

If bus voltage returns, the unit will automatically transition back to aircraft bus power; no pilot action is required. The “ON BATTERY” annunciation will extinguish.

## 8.2.3 Power Loss, Airspeed Below 40 Knots (On-Ground)

When on ground and the bus voltage drops below 7 VDC, the unit will initiate a shut-down sequence. This is the normal “on-ground” shutdown method. Pilot may discontinue the shutdown with any knob or button push.

If bus voltage returns, the shutdown sequence will automatically discontinue, and the unit will return to normal operating mode.

If bus voltage is not returned and the unit remains on, it can be shut down by pressing and holding the left and right buttons until screen goes black.

## 8.3 Battery Charge Status

The battery charge state is shown in percentages from 0 to 100. An internal battery charger will re-charge the battery if bus voltage is above approximately 10 VDC. The battery charge icon (presented adjacent to the battery charge state), will be illuminated during the charge cycle as shown in Figure 60 – Battery Charge Status.



*Figure 60 – Battery Charge Status*

It is normal for the battery charge icon to intermittently flash during the battery charge cycle.

## 9 AoA Operation and Configuration

The following provides a description of how the derived Angle of Attack (AoA) operates and presents the corresponding AoA information to the pilot.

One of the main advantages of an AoA system is that it can provide an early indication of a stall, bringing enhanced awareness to the pilot.

### NOTICE

The AV-30 system is supplemental in nature and does not replace the functionality provided by the aircraft's existing stall warning system.

### 9.1 Operational Methodology

Angle of attack is determined by comparing aircraft pitch to the aircraft flight path angle through the air. In level flight this directly corresponds to the angle at which the wing is intercepting the body of air surrounding the aircraft, correlating to the current AoA.

Pitch is determined by the precision internal AHRS and flight path angle is determined by air-data based airspeed versus vertical speed measurements.

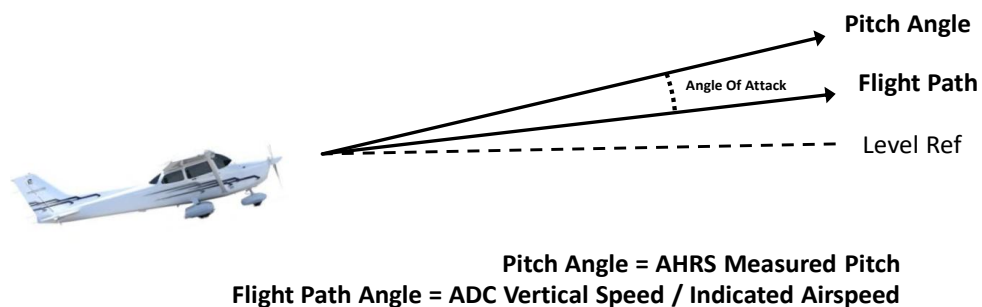

Figure 61 – AoA Computation

As an example of this relationship, during a climb, if the pitch angle is 10 degrees upward, and the aircraft's flight path through the air (forward airspeed and vertical speed) is also 10 degrees upward, the equivalent

AoA is 0 degrees. If, however, the pitch angle is 10 degrees upward, and the aircraft's flight path through the air is only 5 degrees, this corresponds to a positive 5-degree AoA.

A second example is where the pitch is 0 degrees, but the aircraft is descending. The AoA is then equivalent to the descent angle, which will be a negative AoA.

## 9.2 Configured Limits

As each aircraft make and model has different flight characteristics and post-production modifications such as altered wing tips, performance kits and other related modifications may change the flight dynamics of the aircraft, each aircraft has unique configuration limits that must be set for proper AoA operation.

An upper and lower configuration limit is pilot adjustable and provides the scaling mechanism for individual aircraft flight characteristics as it relates to the corresponding AoA display.

### NOTICE

The setting of these configuration limits is implemented with a pilot-lockout feature that prevents inadvertent modification.

The upper near-stall configuration limit is set when the aircraft is in the "base-to-final" configuration with flaps and gear set to their normal positions for this maneuver. This provides the best protection when the aircraft is low-and-slow, and the pilot may inadvertently stall based on over-corrections.

- The upper limit is configured to coincide with the aircraft's existing stall warning system and is typically on the order of 10 to 15 degrees. This visually correlates to the first red bar on the AoA display with the second (upper most) red bar providing indication for operation between the aircraft's stall warning and actual stall point.
- A lower limit is configured to coincide with the AoA at which the aircraft flies under normal cruise conditions. This is typically on the order of 3 to 4 degrees. This visually correlates to the lowest one or two green bars on the AoA display.

The figure below shows how the configured upper and lower limits are mapped onto the color coded AoA indication.

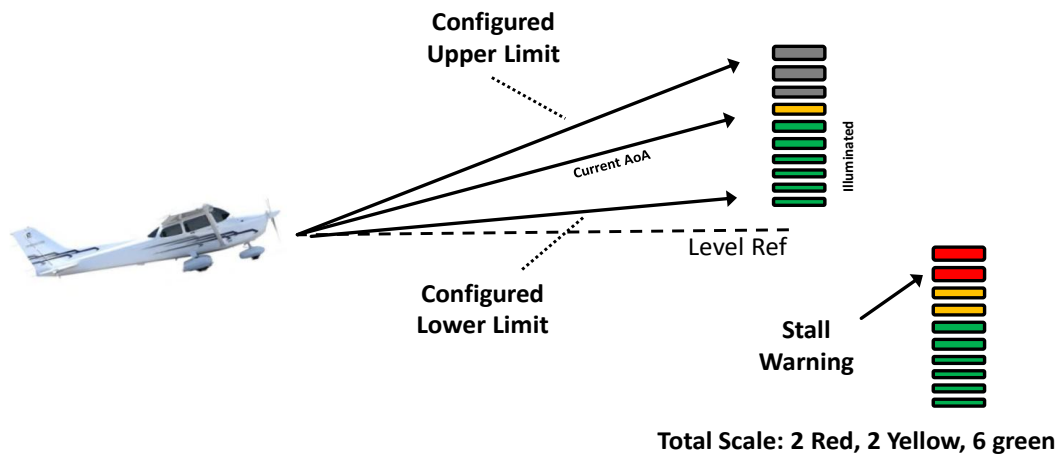

Figure 62 – AoA Upper and Lower Limits

### 9.3 Stable Flight Conditions

Stable flight conditions should be present when determining the upper and lower AoA limits. The in-flight procedures described should be executed when there is minimal turbulence, minimal crosswinds, and the pilot should operate the aircraft as closely as possible to the following:

- Stable power setting
- $\pm 5^\circ$  Heading
- $\pm 5$  Knots Airspeed
- $\pm 50$  Feet Altitude
- $\pm 50$  Ft/Min Vertical Speed

Any offsets beyond the parameters above may directly correlate with AoA errors.

### 9.4 Setting AoA Upper Limit

The objective is to set the upper AoA limit such that the first red bar illuminates at roughly the same time as the on-set of the aircraft's stall warning system.

To find the upper limit, the following procedure is recommended:

- Ensure the AV-30 is in INSTALLATION MODE (see §10.2).
- Select a safe altitude suitable for stalls, minimum 1,500 feet AGL.

- Aircraft Configuration:
  - Airspeed  $V_{FE}$  or less
  - Flaps  $20^\circ$
  - Power as required
  - Stable flight conditions
- Slowly reduce speed at a rate of 1 knot per second and maintain a constant altitude.
- Monitor the displayed AoA as the aircrafts angle of attack increases.
- If the aircrafts stall-warning occurs prior to the indicator reaching the first red bar, the upper AoA limit needs to be numerically lowered to coincide with the aircrafts stall-warning point.
- If the aircrafts stall-warning occurs after the indicator has reached the first red bar, the upper AoA limit needs to be numerically raised to coincide with the aircrafts stall-warning point.
- Utilize the Setup Menu section and associated procedure in this manual to adjust the upper limit as required.
- Repeat the above procedure as needed and to ensure consistency.

## 9.5 Setting AoA Lower Limit

The objective is to set the lower AoA limit such that the first green bar illuminates at roughly  $V_A$  (Gross weight adjusted maneuvering speed).

To find the lower limit, the following procedure is recommended:

- Ensure the AV-30 is in INSTALLATION MODE (see §10.2).
- Select a safe altitude suitable for stalls, minimum 1,500 feet AGL.
- Aircraft Configuration:
  - Airspeed  $V_A$
  - Flaps  $0^\circ$
  - Power as required
  - Stable flight conditions
- Monitor the displayed AoA.
- If no green bars are showing, the lower AoA limit needs to be numerically increased. If more than one green bar is showing, the AoA lower limit needs to be numerically decreased. A fluctuating green bar indicates that the lower AoA limit is acceptable.
- Utilize the Setup Menu section and associated procedure in this manual to adjust the upper limit as required.
- Repeat the above procedure as needed to ensure consistency.



## 9.6 AoA Alert Types and Thresholds

Angle of attack alerts consist of both aural and visual alerts. Three alert levels are provided and are triggered on how close the current AoA is to the configured upper limit (as a percentage).



Level	Percent	Aural	Visual
Alert 1	80%	One Tone	
Alert 2	90%	Double Tone	
Alert 3	100%	“Check Angle”	

Table 6 – AoA Alert Limits

When an alert is being generated, pressing any button will mute the alert. AoA alerts can also be completely disabled under the pilot preference settings.

## 9.7 Flap Setting Observations

When the upper AoA limit is configured for the “base-to-final” flap setting, and the lower AoA limit is configured for the normal “cruise” flap configuration, the indicated AoA will vary from this baseline when flaps are configured for other phases of flight. The pilot should document the actual indications provided for the various phases of flight.

In Table 7, please highlight the actual AoA presentation for the indicated phase of flight.

Flap Setting	Flaps Up	Flaps Down
Pre-Stall		
Climb Vx		
Climb Vy		
Cruise		
Best Glide Speed		
Approach		
1.3 Vs		
1.2 Vs		
1.1 Vs		

Table 7 – AoA Observations

## 10 Setup Menu

The setup menu allows customization of settings that are pilot-accessible. Installer-only related settings are found in *AV-30-E Installation Manual UAV-1004234-001*. Installation settings must be adjusted on the ground.

To access the Setup Menu, push the Menu button twice until the SETUP is shown in the lower window.



Figure 63 – Setup Menu Access

Rotating the knob left and right will access the various parameters that may be configured.



Figure 64 – AOA Alert Setting

Press and release the knob when the desired field is shown to adjust the associated setting. After adjustment, pressing and releasing the knob again will exit editing mode. Pressing DONE or a lack of user input for 30 seconds will exit the setup menu and return to the primary screen.

## 10.1 Pilot-Accessible Setup Menu

The Setup Menu is available on ground or in flight. Table 8 contains the options available in the Setup Menu.

Setting	Description	Options / Setting Range
UI STYLE	Sets Visual Style	LEGACY, EFIS, VINTAGE
UI FONT	Sets Font Style	ARIAL, LCD
G RESET	Rests the G Load Min and Max hold	PUSH TO RST
COURSE DEV	Enables course deviation on AI and DG ARC modes	DISABLED, ENABLED
GLIDESLOPE	Enables glideslope (when valid signals are received) on AI and DG ARC modes	DISABLED, ENABLED
AUDIO VOL	Audio Volume for Alerts	0 to 10
AOA ALERT	Enable AoA Alerts	DISABLED, ENABLED
AOA HIGH LIM*	Upper AoA Limit	-28 to 30
AOA LOW LIM*	Lower AoA Limit	-30 to 28
G ALERT	Enable G Load Alert	DISABLED, ENABLED
G POS LIM	Positive G Limit	2 to 8
G NEG LIM	Negative G Limit	-1 to -8
ROLL ALERT	Enable Roll Alert	DISABLED, ENABLED
ROLL LIM	Roll Alert Threshold	30 to 80
TURN COORD	Sets the depiction used for turn coordinator – rate of turn or standard rate bank angle	TURN RATE, BANK ANGLE
MIN VOLT	Minimum voltage threshold. Below this number the BUSV indicator will turn red, indicating a charging system problem	10.0 to 32.0
MAX VOLT	Maximum voltage threshold. Above this number the BUSV indicator will turn red, indicating a charging system problem	10.0 to 32.0
TRAK STAB	Inertial Track Smoothing	DISABLED, ENABLED
HOURS	Lifetime hours of operation	For reference

Table 8 – Setup Menu Settings

## NOTICE

(\*)AoA limits cannot be changed unless installation mode is enabled. The high and low limit ranges are interdependent.

---

AoA limits are locked out during normal operation to prevent inadvertent modification.

---

To access these settings, activate the INSTALLATION MODE by pressing the center knob while initial power is being applied to the unit. See *AV-30-E Installation Manual UAV-1004234-001* for details. These settings are then available to be modified until the unit's power is cycled.

---

Also note that in installation mode, an additional Install Menu is available. The pilot should not make any changes to settings in the Install Menu.

---

### 10.2 Non-Pilot Accessible Install Menu

The AV-30 also includes an Install menu that is used for configuration. This menu should not be used in flight. Additional information about the Install menu can be found in *AV-30-E Installation Manual UAV-1004234-001* for details.

# 11 AV-Link

## 11.1 Overview

The AV-Link is an integrated Wi-Fi bridge that allows for communication between AV-30 and Wi-Fi enabled devices.

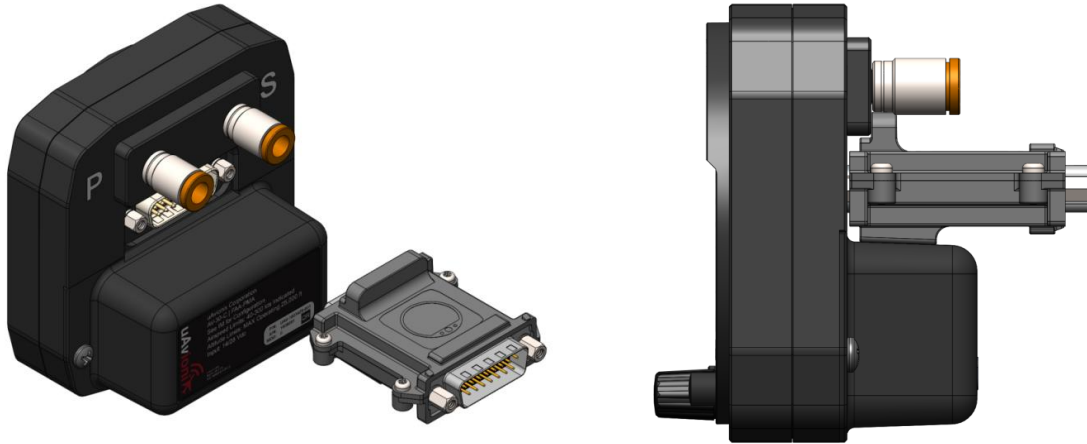

Figure 65 – AV-Link Attached to AV-30

The AV-Link allows for the integration of portable ADS-B devices such as Sentry and Sentry Mini to provide ADS-B traffic and GPS to an AV-30. Software updates for the AV-Link and AV-30 can be performed via the embedded web page. AV-Link configuration settings and device status are also accessible through the embedded web page.

When connected to a Sentry with a Carbon Monoxide (CO) sensor, the AV-Link will display CO status and alerts on the AV-30.

### NOTICE

The AV-Link accessory is not powered by the AV-30 internal battery. Wi-Fi traffic data provided to the MFD mode will be unavailable during a power loss.

## 11.2 Additional Required Equipment

AV-Link is designed to interface with an existing Wi-Fi capable ADS-B receiver and the AV-30 display. To fully take advantage of the AV-Link, the following equipment is required:

- AV-30 Display
- ADS-B Receiver with GPS and Wireless capability

### 11.3 Connecting

Support for Windows, MacOS, iOS and other devices are supported, using the built-in web browser support on your computer. To connect to the AV-Link, configure your computer to connect to the AV-Link Wi-Fi connection.

1. Power the AV-Link by attaching AV-Link to AV-30 to provide power. See *AV-30-E Installation Manual UAV1004234-001* for details.
2. Once the AV-Link is powered, on your computer, connect to the AV-Link Wi-Fi hotspot, which will have a “AV\_XXXX” SSID, where XXXX is a combination of alpha-numeric characters.

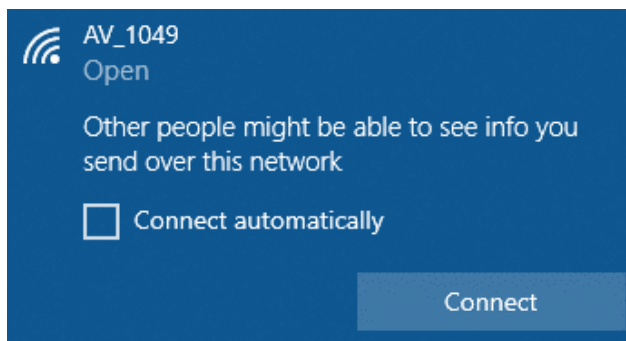

If the AV-Link Wi-Fi network does not appear in your connection list, power cycle the AV-Link and check again. As of AV-Link version 0.3.2, the AV-Link Wi-Fi access point will turn off automatically after 5 minutes if no clients connect to it and there is no connected AV-30 configured to interface with it. Power-cycling the AV-Link refreshes this timeout.

3. Once connected, use your web browser to navigate to 192.168.5.1. From there, you will see the AV-Link main web page.

## 11.4 Home Page

Note: Accessing the AV-Link web pages while in flight is not recommended and may disrupt normal operations of the AV-Link. All settings changes should be performed while on the ground.

The AV-Link main web home page provides both status information and methods to control settings. The screen is separated into three sections, the *Settings*, *Status*, and connected *Device Information*.

### 11.4.1 Settings

The settings panel contains information about the AV-Link. The software version, AV-Link SSID, number of clients connected to the AV-Link and information about any ADS-B receiver connected via Wi-Fi.

### 11.4.2 Status

When connected to an ADS-B receiver, information received such as the ownship ICAO address, callsign, GPS location information as well as the current altitude is frequently updated.

### 11.4.3 Device Information

Connected devices, such as the uAvionix AV-30 display or the Sentry ADS-B receiver, will be shown with the device serial number and version, if available. When the device is disconnected, it is removed from this list.

AVLink Main Device Page

Not secure 192.168.5.1

#### Settings

Software	<a href="#">UAV-1005439-001-0.3.4-AVLink</a>	
AV-Link SSID	AV_D5B1	
Clients	1	
ADS-B Receiver	<a href="#">Not assigned</a>	Waiting to scan

#### Status

ICAO Address	000000
Callsign	-----
GPS Fix	None
GPS Satellites	0
Position	---
Altitude (GNSS)	---
Altitude (Baro)	---

#### Device Information

Hardware	Version	Serial Number
AV-Link	<a href="#">0.3.4</a>	83638828127665
AV-30	<a href="#">2.5.0</a>	3472927375564027189

[Wi-Fi Settings](#)   [Statistics](#)   [AV Display](#)  
[Software Update](#)



## 11.4.4 Navigating to Other Pages

Navigating to other AV-Link web pages is done using the web links at the bottom of the page.

[Wi-Fi Settings](#)

[Statistics](#)

[AV Display  
Software Update](#)

Wi-Fi Settings is used to configure the AV-Link and ADS-B Wi-Fi settings, Statistics is used to provide access to real-time system statistics and AV Display Software Update is used to update a connected AV-30 display with new firmware.

## 11.5 Wi-Fi Settings Page

The AV-Link Wi-Fi settings page provide a way for the user to configure wireless connections. The screen is separated into two sections, the main Wi-Fi settings for the AV-Link (upper) and Wi-Fi settings for connecting to a remote ADS-B receiver (lower).

This chapter of the Pilot's Guide covers the ADS-B receiver settings section.

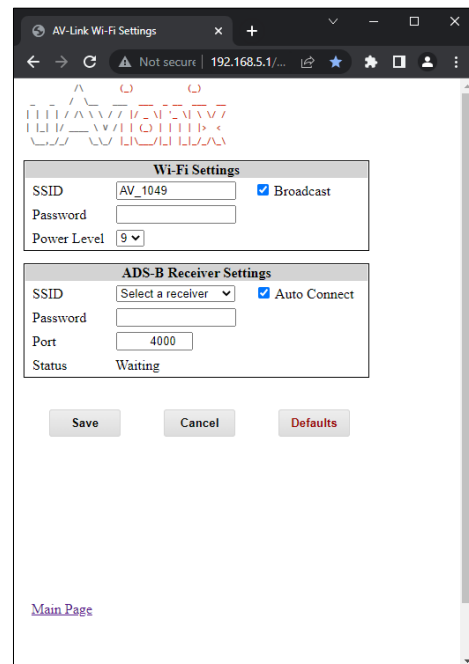

Figure 66 – AV-Link Wi-Fi Settings

### 11.5.1 ADS-B Receiver Settings

#### SSID

The AV-Link will automatically connect to any uAvionix manufactured ADS-B receiver.

If connecting to a different receiver, it is necessary to populate the Service Set Identifier (SSID) field with the name of the Wi-Fi network used by that

receiver. If this value is set, the AV-Link will first attempt to connect to the named device.

When the AV-Link scans for available ADS-B receivers, the SSID drop down list is populated with the device names that it discovers.

If a custom ADS-B is desired, select 'Enter a custom receiver' and enter the name of the custom device.

If removing the custom ADS-B receiver is desired, select 'Remove custom receiver' and click Save.

## **AUTO CONNECT**

By default, AV-Link will automatically identify preferred uAvionix ADS-B devices and connect to them, making the initial use very simple.

If AV-Link has been configured with a preferred device and the named device is not available and Auto Connect is checked, then AV-Link will attempt to connect to any of the preferred uAvionix ADS-B devices it discovers.

Examples of these are:

- Sentry.
- Sentry Mini.
- SkyEcho.
- echoUAT.
- skySensor.

Unchecking Auto Connect will disable auto-discovery of uAvionix preferred ADS-B devices.

## **NOTICE**

In order to preserve resources of an ADS-B receiver when there are multiple AV-Links in a cockpit, and because a connection to an ADS-B receiver is only required for use with the AV-30 MFD, the AV-Link will not connect to any ADS-B receiver unless the MFD mode is enabled by setting the SERIAL 3 installation option to AVLINK.

## **PASSWORD**

If password security is used on the ADS-B receiver, entering a password into this field and clicking on Save will set this password. The password must be a minimum of 8 characters to meet security requirements.

## **PORT**

If the ADS-B receiver being used transmits GDL90 packets on a port that is different than 4000, entering the port number and clicking on Save will set this custom port. Valid values are 1-65535.

## **STATUS**

This status reference will frequently update with the current status of the Wi-Fi connection to your ADS-B receiver.

# 12 Autopilot

The AV-30 can control select autopilots using the following interfaces:

- Digital heading, altitude, and vertical speed using RS-232
- Digital heading, course, and altitude using ARINC 429 with the AV-HSI
- Analog heading and course using the AV-APA

RS-232 may be used to control a BendixKing xCruze / AeroCruze 100 / TruTrak Vizion (385 and PMA) or a Trio Pro Pilot autopilot. Heading, Set Altitude and Set Vertical Speed, and Autopilot Mode are selected on the AV-30 and sent to the autopilot via a serial link. The controls are available in both AI and DG modes.

When configured with the AV-HSI, ARINC 429 may be used to control a BendixKing xCruze / AeroCruze 100 / TruTrak Vizion (385 and PMA) or a Trio Pro Pilot autopilot. Heading, OBS, Set Altitude, and Autopilot Mode are selected on the AV-30 and sent to the autopilot via the AV-HSI. The controls are available in both AI and DG modes.

With the optional AV-APA installed and configured, the AV-30 can be used to control S-TEC 20/30/40/50/55/60-2 autopilots. Heading modes are selected on the AV-30 in both AI and DG modes and sent to the autopilot through the AV-APA. Autopilots connected through the AV-APA analog interface do not support Set Altitude and Set Vertical Speed modes.

## 12.1 Autopilot Modes

There are five autopilot direction modes as shown in Table 9 – Autopilot Modes. The PUSH-SET menu sequence will guide the pilot through all required inputs. The PUSH-SET sequence includes SET BARO, HDG BUG, SET ALT, AUTOPILOT, and DG ADJ.

The items and order of appearance will vary based on the autopilot mode and installation configuration. All five autopilot direction modes can be made available to analog autopilots connected with the AV-APA. Digital autopilots connected to the AV-HSI are limited to OFF, HDG BUG, and GPSS (if unlocked).

When using the Heading Bug autopilot mode, the AI and DG direction indicators will automatically switch to display DG heading. Similarly, using

some GPS-based autopilot modes will automatically switch the direction indicators to display GPS track, as described in the table below.

AP Mode	Desired Direction	Current Direction	Desired Altitude	Desired Vertical Speed	PUSH-SET Sequence (DG mode <sup>(1)</sup> )	Auto Display Change	
						Indicator	AI/DG Direction
OFF	NA	NA	NA	NA	HDG BUG DG ADJ <sup>(2)</sup> BARO SET ALT SET VS AUTOPILOT	Heading Bug (used only for pilot reference)	NA/NA
HDG BUG	Heading Bug	DG Heading	SALT	SVS	HDG BUG DG ADJ <sup>(2)</sup> BARO SET ALT SET VS AUTOPILOT	Heading Bug	DG Tape/ DG Heading Rose
TRK BUG	Heading Bug (referenced to GPS Track)	GPS Ground Track	SALT	SVS	HDG BUG BARO SET ALT SET VS AUTOPILOT	Heading Bug	GPS TRK Tape/ GPS TRK HSI or ARC
GPSS <sup>(3)</sup>	Steering from an ARINC-429 GPS	GPS Ground Track	SALT	SVS	HDG BUG BARO SET ALT SET VS AUTOPILOT	Hollow Commanded Heading Reference	NA/NA
WPT DTRK	Desired track to waypoint	GPS Ground Track	SALT	SVS	BARO SET ALT SET VS AUTOPILOT	Hollow Commanded Heading Reference	GPS TRK Tape/ GPS TRK HSI or ARC
WPT BRG	Bearing to waypoint	GPS Ground Track	SALT	SVS	BARO SET ALT SET VS AUTOPILOT	Hollow Commanded Heading Reference	GPS TRK Tape/ GPS TRK HSI or ARC

Table 9 – Autopilot Modes

- (1) In AI Mode BARO appears first followed by DG ADJ or HDG BUG
- (2) DG ADJ appears last in the sequence if an AV-Mag is installed
- (3) Requires AV-HSI and the Advanced Autopilot Software Unlock. See Installation Manual for details

When using the AV-APA, a red ‘NO AP’ flag will appear if the AV-30 does not have the required data to support the selected autopilot mode. For example, the flag will appear if the pilot selects “WPT DTRK” but the GPS doesn’t have a next waypoint. The ‘NO AP’ flag will also appear if the AV-30-C loses communication with the AV-APA. Either case is an indication to the pilot that the AV-30-C and AV-APA are not providing valid direction input to the Autopilot.

### 12.1.1 Heading Bug

The autopilot will fly the heading specified by the heading bug, relative to the directional gyro indicated heading. This heading will not compensate for wind or gyro drift. When flying with Heading Bug or Track Bug mode, the Heading Bug will be a solid magenta “bowtie” indicator.



### 12.1.2 Track Bug

The autopilot will fly the GPS track specified by the heading bug. This is ground track and therefore compensates for wind.

### 12.1.3 GPS Steering (GPSS)

When using an AV-HSI, a panel mounted navigator, and the Advanced Autopilot Software Unlock, the autopilot can follow steering commands from the GPS. This includes joining and tracking a flight plan. Most WAAS capable GPS also provide GPSS guidance for holding patterns and course reversals.

When flying any of the GPS modes, the heading bug is replaced by a hollow magenta “bowtie” indicating the heading commanded to the autopilot.



### 12.1.4 Desired Track to Waypoint

The autopilot will fly the desired track, as specified by the GPS, to the next waypoint. If the aircraft is off course, this mode will result in the aircraft flying a path parallel to GPS magenta course line. The aircraft will continue flying on this desired track until the GPS sequences to the next waypoint, at which time the aircraft will begin a turn to the next desired track.

### **12.1.5 Bearing to Waypoint**

The autopilot will fly the bearing to the next waypoint, as specified by the GPS, to the next waypoint. If the aircraft is off course, this mode will result in the aircraft flying a path directly to the next waypoint. The aircraft will continue flying this bearing until the GPS sequences to the next waypoint, at which time the aircraft will begin a turn to the next waypoint bearing.

## **12.2 Autopilot Control**

### **12.2.1 Selecting Heading**

- In AI mode, push and release the center knob multiple times until 'HDG BUG' appears
- In DG mode, either turn the center knob directly or push and release the center knob to bring up the 'HDG BUG' adjustment window
- Rotate the knob clockwise or counterclockwise to select the heading
- Push and release the center knob to advance to the next setting

### **12.2.2 Selecting Altitude**

- Push and release the center knob to open the PUSH-SET menu
- Push and release the center knob until 'SET ALT' appears
- Rotate the center knob to set the desired SALT
- The SALT value displayed in the overlay field will change from white to green when the aircraft altitude reaches  $\pm 100'$  of the SALT value
- Note that SALT has a default value of 5000' on first use. On subsequent uses the AV-30-C will recall the last value entered
- The next push of the center knob will save the 'SET ALT' and bring up the 'SET VS' entry field

### **12.2.3 Selecting Vertical Speed**

- If not already on the 'SET VS' entry field, push and release the center knob until 'SET VS' appears
- Note that the SET VS is initialized to the current vertical speed after a new SALT is entered. If SALT is not adjusted, then the last entered SVS is retained
- Rotate the center knob to set the desired vertical speed
- Push and release the center knob to advance to the next setting
- Set VS will reset to zero upon reaching the desired set altitude

- Note: If in AI mode and the vertical trend indicator is visible, the magenta SVS bug will now appear on the vertical trend indicator. See §5.5.9 for more information about the vertical trend indicator. In DG mode, there are no SVS overlay indicators other than the value shown in the PUSH-SET menu



Figure 67 – Selected Vertical Speed entry

#### 12.2.4 Selecting Autopilot Mode

- If not already on the 'AUTOPILOT' entry field, push and release the center knob until 'AUTOPILOT' appears
- Rotate the center knob to select the desired mode. The new mode is not engaged until you push and release the center knob
- If the knob is not pushed and released within 30 seconds, the menu window will be dismissed automatically, and the prior autopilot mode is retained
- When the new autopilot mode is selected, the display will automatically change to match the type of direction used in the mode. See Table 9 – Autopilot Modes for the display changes that accompany autopilot mode selection
- It is not recommended to undo the automatic display change to display a direction type that does not match the autopilot control type. I.e. do not display a DG heading rose when GPS ground track is sent to the autopilot and vice versa



## 13 Stored Data Integrity Check

Configuration and calibration data stored in non-volatile memory is checked with Cyclic Redundancy Check (CRC) checksums on every power up event. If a data section is found to be corrupted, the user is notified at the power-up splash screen. In some cases, the corrupted values will be set to their defaults. Any additional restoration remedy varies with the type of data. See Table 10 – Integrity Checked Data and Remedies.

Message	Data Type and Description	Remedy
"WARNING: OVERLAY reset to defaults. Reconfig required."	Overlay settings. This data is used to determine which fields are active and which data are displayed in those fields.	User to reconfigure overlay fields on AI, DG, and CDI pages as per preference or installation log.
"WARNING: CFG reset to defaults. Reconfig required."	Configuration settings. Trim settings, page selection, AI/DG mode selection, function lock, etc.	Re-set configuration items as per recorded setting in the installation log. AV-Mag calibration, airspeed trim, and altitude trim are not affected.
"ERROR: F-CAL value check failure. Verify user calibration data."	Field Calibration. Magnetometer calibration, Altitude trim calibration, pitot-static zero-point setting.	If applicable, recalibrate: <ul style="list-style-type: none"> <li>• magnetometer</li> <li>• altitude trim</li> <li>• indicated airspeed</li> <li>• re-zeroing of the pitot-static zero-point</li> </ul>
"ERROR: PROV value check failure. Service required."	Provision settings. These are settings set at the factory.	Contact customer support. Cannot be reconfigured by the user.
"ERROR: Problem with bootloader. Factory service required"	Bootloader software. Software that launches the main software after power-up.	Contact customer support. Cannot be reconfigured by the user.

Table 10 – Integrity Checked Data and Remedies

# 14 Operating Limits & System Specifications

Operating Limits	
Startup Time	< 3 Minutes
Attitude Rate Limit	±250 degrees per second
Attitude Operational Range	360° Roll, 180° Pitch
Attitude Accuracy	1° Static, 2.5° Dynamic
Airspeed Operational Range	40 to 300 kts
Altitude Operational Range	-1,000 to +25,000 ft
AoA Operational Range	-10° to +30°
AoA Resolution	1°
AoA Valid Speed Range	+35 to +300 kts
AoA Accuracy	2.5°
DALT Operational Range	-5400 to +35,700 ft
DALT Accuracy	± 500 ft
TAS Operational Range	+35 to +300 kts
TAS Accuracy	± 20 kts
G-Load Operational Range	± 8 g
OAT Operational Range	-40°C to +70°C
OAT Accuracy	±4°C
Bus Voltage Range	7 to 35 Volts
Bus Voltage Accuracy	±1.0 Volt

Table 11 – Operating Limits

# 15 List of Figures

Figure 1 – AV-30 Multi Mode AI/DG/Transponder – Basic Display .....	11
Figure 2 – AV-30 Aircraft Systems Interfaces – AI Mode .....	15
Figure 3 – AV-30 Aircraft Systems Interfaces – DG, MFD, or CDI Mode .....	16
Figure 4 – Splash Screen .....	22
Figure 5 – Common User Interface Components .....	22
Figure 6 – Push-Set Example – SET BARO .....	25
Figure 7 – Page 1 of 3 showing Air Data and DG Heading .....	27
Figure 8 – Page 2 of 3 showing GPS Ground Track, AoA, and Vertical Trend .....	27
Figure 9 – Page 3 of 3 showing Waypoint Data and SALT .....	28
Figure 10 – UI Customization, Menu Entry .....	29
Figure 11 – UI Customization - Field Selection .....	29
Figure 12 – Display Edit Value .....	30
Figure 13 – Basic AI Mode User Interface .....	31
Figure 14 – AI Mode, Customizable Field Locations .....	31
Figure 15 – Data Overlay Examples .....	32
Figure 16 – AI Mode, Attitude Indicator .....	32
Figure 17 – AI Mode, Rate of Turn Indicator .....	34
Figure 18 – AI Mode, Standard Rate Bank Angle Indicator .....	34
Figure 19 – AI Mode, IAS Indicator .....	35
Figure 20 – AI Mode, V-Speed Limits .....	35
Figure 21 – AI Mode, Direction Indication, Bearing To Off-Screen .....	36
Figure 22 – AI Mode, Altitude Indicator .....	37
Figure 23 – AI Mode, AoA Indication .....	38
Figure 24 – AoA Computation .....	38
Figure 25 – AI Mode, Vertical Trend Indication .....	39
Figure 26 – AI Mode, Vertical Trend Indicator and SVS Bug .....	39
Figure 27 – SVS Bug value greater than scale .....	39
Figure 28 – AI Mode, G-Load Indication .....	40
Figure 29 – AI Mode, Course Deviation and Glideslope Indication .....	41
Figure 30 – AI Mode, ILS Course Deviation and Glideslope Indication .....	41
Figure 31 – AI Mode, GPS LOI Indication .....	42
Figure 32 – AI Mode, Waypoint Indication .....	42
Figure 33 – AI Mode, Text Fields .....	43
Figure 34 – Basic DG Rose Mode User Interface .....	44
Figure 35 – Non-Slaved DG HSI User Interface .....	45
Figure 36 – Non-Slaved DG HSI User Interface with VOR Guidance .....	46
Figure 37 – GPS-Slaved HSI Mode with VFR GPS .....	47
Figure 38 – Arc Mode with Course Deviation and Glideslope .....	48
Figure 39 – Arc Mode with Holding Pattern .....	49
Figure 40 – Arc Mode without Course Deviation and Glideslope .....	49
Figure 41 – BUSV Threshold Setup .....	53
Figure 42 – AV-30 Traffic Page .....	54
Figure 43 – Traffic Display .....	57
Figure 44 – Traffic Display Zoom .....	57
Figure 45 – Traffic Target Relative Altitude .....	58
Figure 46 – Traffic Target Tracking Function .....	59

Figure 47 – Traffic Reversionary AI Activation .....	60
Figure 48 – Examples of Alternate Filter Values .....	62
Figure 49 – MFD with VSI Overlay .....	63
Figure 50 – CDI Mode with GPS Guidance .....	63
Figure 51 – CDI Mode with VOR Guidance .....	64
Figure 52 – Reversionary Attitude Indicator .....	64
Figure 53 - Transponder Control.....	65
Figure 54 - Squawk Overlay Push-Set Menu.....	68
Figure 55 - Brightness Menu.....	69
Figure 56 – UI Style Options .....	70
Figure 57 – Example of Alert Annunciator on Screen .....	71
Figure 58 – Battery Test Indicators.....	74
Figure 59 – On Battery Operation .....	75
Figure 60 – Battery Charge Status .....	76
Figure 61 – AoA Computation .....	77
Figure 62 – AoA Upper and Lower Limits .....	79
Figure 63 – Setup Menu Access .....	83
Figure 64 – AOA Alert Setting .....	83
Figure 65 – AV-Link Attached to AV-30 .....	86
Figure 66 – AV-Link Wi-Fi Settings.....	89
Figure 67 – Selected Vertical Speed entry .....	96

# 16 List of Tables

Table 1 – GPS Error Messages .....	50
Table 2 – Data Overlay Types vs Operational Mode.....	52
Table 3 – MFD Configuration Options .....	62
Table 4 – Transponder Status .....	66
Table 5 – Envelope Alert Types and Priorities .....	72
Table 6 – AoA Alert Limits.....	81
Table 7 – AoA Observations.....	82
Table 8 – Setup Menu Settings .....	84
Table 9 – Autopilot Modes .....	93
Table 10 – Integrity Checked Data and Remedies .....	97
Table 11 – Operating Limits .....	98