

UAVIONIX.COM/DEFENSE



IFF NATIONAL SECURITY SYSTEMS





LOW SWaP NO COMPROMISE

uAvionix ZPX systems enable secure Mode 5 platform identification for Uncrewed Aircraft Systems (UAS). ZPX transponders, receivers, and the Combined Transponder Receiver (CTR) deliver functionality and performance like those on crewed aircraft, but at a Size, Weight, and Power (SWaP) suitable for tactical UAS, even those weighing only 6 kg (Group 1). The ZPX systems are supported by crypto emulators available from uAvionix that enable Mode 5 development and testing without the security burdens imposed by actual crypto use, and they include Mode S/1090ES ADS-B functionality to simplify the equipment needed by military aircraft transiting civil airspace.

ZPX-A MODE S TRANSPONDER

MODES 3/A,C,S,
ADS-B OUT



RT-2087/ZPX IFF TRANSPONDER

MODES 1,2,3/A,C,S,5L1,5L2,5L2-B
ADS-B OUT + ADS-B RECEIVER



RT-2087/ ZPX-1 IFF COMBINED TRANSPONDER RECEIVER

MODES 1,2,3/A,C,S,5L1,5L2,5L2-B
ADS-B OUT + ADS-B
M5L2 AND L2-B SQUITTER RECEIVER



ZPR MODE 5 RECEIVER

ADS-B, M5L2 AND L2-B
SQUITTER RECEIVER



UNRIVALED SWaP

- Available in LRU and surface mount versions to support any aircraft configuration
- Solutions as light as 50 grams
- Power consumption 3.5W Nominal
- 54 dBm transmit power (250W)
- Crypto Ready

NO COMPROMISE

- Mode 5 AIMS certification to Mk XIIIB Levels 1/2
- ICAO Annex 10
- DO-181E Class 1, Level 2
- DO-260B Classes A and B
- Environmental Testing: MIL-STD-810H
- RF Testing: MIL-STD-461G

OPTIONS

- Available in LRU or surface mount
- truFYX TSO-C145e GPS/WAAS
- KIV Emulator for rapid integration
- Monopole and Dipole antennas
- National Secure Mode
- AV-30M Control Head and Tactical Traffic Display





ZPX-A MODE S TRANSPONDER



The ZPX-A is a comprehensive system designed to fulfill the Transponder and Automatic Dependent Surveillance – Broadcast (ADS-B) surveillance requirements for both civilian and military users aiming to operate an Uncrewed Aircraft (UA) in controlled airspace. It is derived from the successful uAvionix TSO-certified ping200X Mode S transponder with Design Assurance Level C. Enhancements to support military users include the control of the X-bit in Mode A replies and individual on/off mode control.

SPECIFICATION	VALUE
Input Voltage/Power	11-34V (3S-8S LiPo) 1.5W Continuous On/Alt. 4W Peak (8ms maximum)
Size	47 x 54 x 9 mm
Weight	50 grams
Operating Temp	-45° to 70° C

TRANSPONDER	
Modes 3/A, C, S 1030 MHz Rx MTL (sensitivity)	-74 dBm ±3 dB
1090 MHz Tx Power	54 dBm (Nominal)

ALTIMETER	
Range Accuracy	-1000 to 35,000ft - per AS 8003 35,000 – 60,000ft, ±1%

CONTROL INTERFACE	
Baud Rate	1200 to 2 Mbps
Protocol	GDL90+

POSITION INTERFACE	
Baud Rate	115,200 bps
Protocol	uAvionix OEM Protocol

OPTIONS	
1030/1090 MHz Transponder Antenna	
uAvionix truFYX TSO-C145e Position Source	
Similar unit available with TSO (vs. AIMS) certification, without X-bit control & Mode selection	

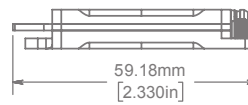
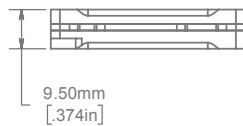
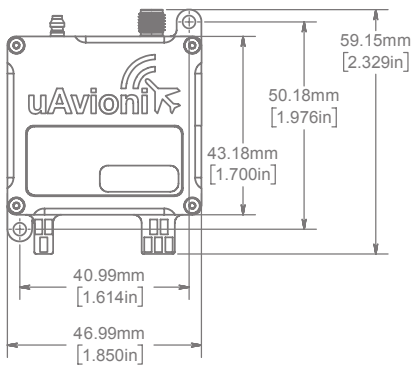
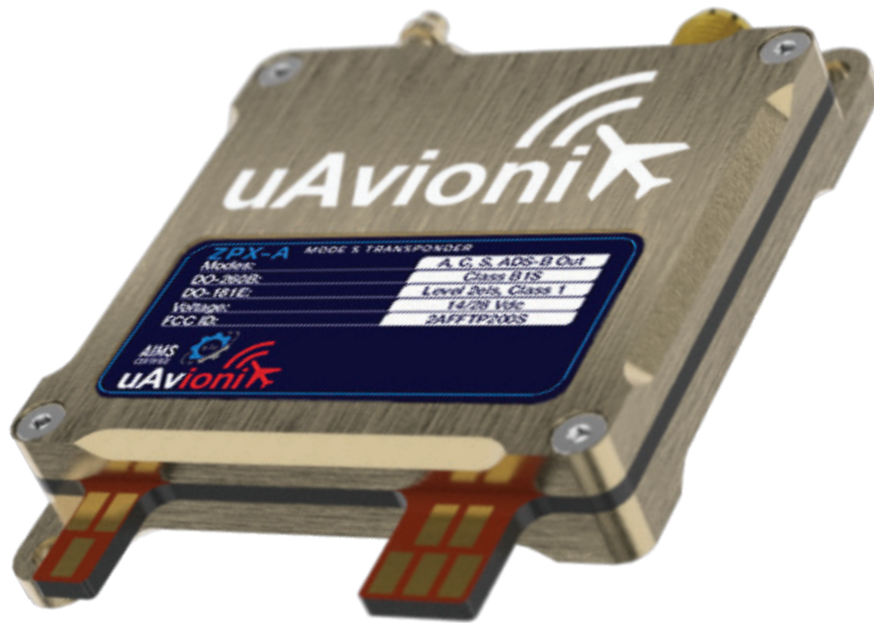



RT-2087/ZPX MODE 5 TRANSPONDER



The RT-2087/ZPX is a complete, low-SWaP Combat ID, and Air Traffic Control surveillance system designed to meet encrypted Identification Friend or Foe (IFF), unencrypted civil and military transponder, and ADS-B and Mode 5 squitter requirements for UAS operating in both battlefield and civilian airspaces. When combined with a micro-crypto (e.g., KIV-79), small and tactical UAS benefit from interoperability using Mode 5—the latest IFF encryption standard adopted by NATO and its allies. Crypto emulators are available for non-classified development, testing, and NSM operation. ADS-B In is a supported native function providing Detect and Avoid (DAA) functionality. Ethernet control is an available option.

SPECIFICATION	VALUE
Input Voltage/Power	11-33VDC 3.5W Continuous (NORMAL) 4W Peak (8ms maximum)
Size	83 x 47 x 15 mm
Weight	68 grams
Operating Temp	-45° to 71° C

TRANSPONDER	
Modes 1, 2, 3/A, C, S 1030 MHz MTL (sensitivity)	-76 dBm ±2 dB
Mode 5 MTL (sensitivity)	-80 dBm
1090 MHz Tx Power	250 W (54 dBm)

ALTIMETER	
Range Accuracy	TSO-C88b compliant up to 35,000ft 35,000 to 60,000 ft, ±1%

ADS-B TRAFFIC INTERFACE	
Baud Rate	115,200 bps RS-232
Protocol	GDL90

CONTROL INTERFACE	
Baud Rate	57,600 bps RS-485/-232
Protocol	GDL90+

POSITION INTERFACE	
Baud Rate	115,200 bps RS-232
Protocol	uAvionix OEM Protocol

KIV INTERFACE	
AIMS 04-900(A)	Option B (KIV-77 / KIV-79)

OPTIONS	
1030/1090 MHz Transponder Antenna	
uAvionix truFYX TSO-C145e Position Source	
NSM programming for crypto emulator	
Crypto emulators (KIV-77 and KIV-79) for interrogators, test equipment, and development/test of transponders	

DEVELOPED IN PARTNERSHIP WITH



RT-2087/ZPX
AIMS MK XIIB
 MODE 5 IFF TRANSPONDER

Mode:	1, 2, 3/A, C, S, 5 L1/L2
DO-260B:	Class A1S
DO-181E:	Level 2a/s, Class 1
Voltage:	11-33 Vdc
CAGE Code:	7MYA0

AIMS
 uAvionix

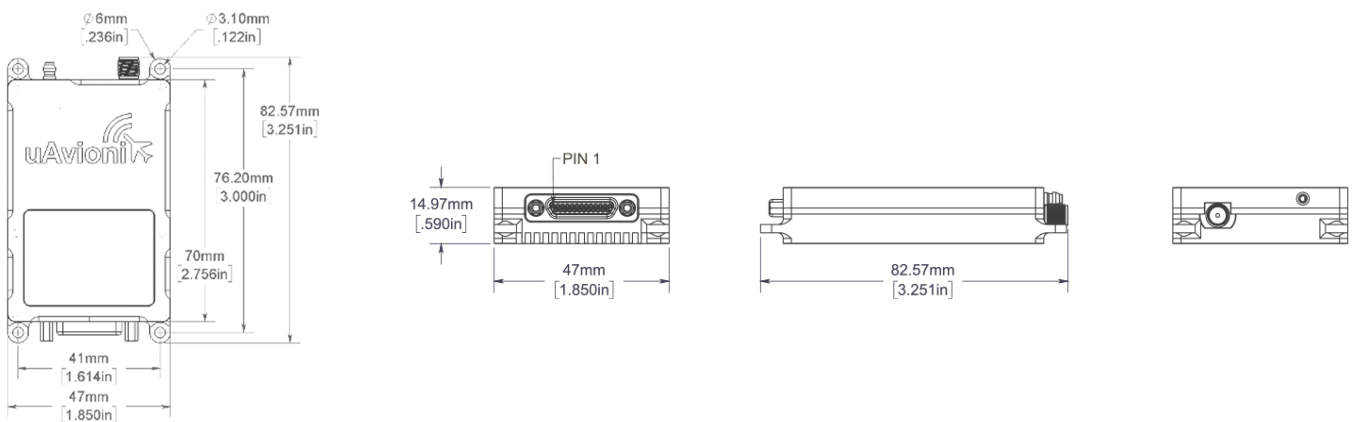



RT-2087/ZPX-1 MODE 5 IFF COMBINED TRANSPONDER RECEIVER



The RT-2087/ZPX-1 is a complete, low-SWaP Combat ID system designed to satisfy encrypted Identification Friend or Foe (IFF), civil and military transponder, and Automatic Dependent Surveillance – Broadcast (ADS-B) and Mode 5 squitter requirements for Uncrewed Aircraft Systems (UAS) operating both in battlefield and civilian controlled airspace. When combined with a micro-crypto (e.g. KIV-79), small and tactical UAS benefit from interoperability using Mode 5—the latest IFF encryption standard adopted by NATO and its allies.

SPECIFICATION	VALUE
Input Voltage/Power	11-33VDC 3.5W Continuous (STBY) 5.5W Continuous (NORMAL) 6W Peak (8ms maximum)
Size	83 x 47 x 21 mm
Weight	91 grams
Operating Temp	-45° to 71° C

TRANSPONDER	
SIF & Mode S MTL @ 1030 MHz MTL (sensitivity)	-76 dBm ±2 dB
Mode 5 MTL (sensitivity)	-80 dBm
1090 MHz Tx Power	250W (54 dBm)

RECEIVER SENSITIVITY	
ADS-B Rx MDL	-79 dBm ±2 dB
Mode 5 MDL L2/2-B Rx	-84 dBm

ALTIMETER	
Range	-1000 to 126,750 ft

CONTROL INTERFACE	
Baud Rate	57,600 bps RS-485/-232
Protocol	GDL90+

POSITION INTERFACE	
Baud Rate	115,200 bps RS-232
Protocol	uAvionix OEM Protocol

MODE 5 LEVEL 2/2B AND ADS-B IN TRAFFIC	
Baud Rate	115,200 bps RS-232
Protocol	GDL90+ / DoD AIMS 23-901

KIV INTERFACE	
AIMS 04-900(A)	Option B (KIV-77 / KIV-79)

OPTIONS	
1030/1090 MHz Transponder Antenna	
10/100 Ethernet Adapter	
uAvionix truFYX SIL 3 Position Source	
NSM programming for crypto emulator	

DEVELOPED IN PARTNERSHIP WITH

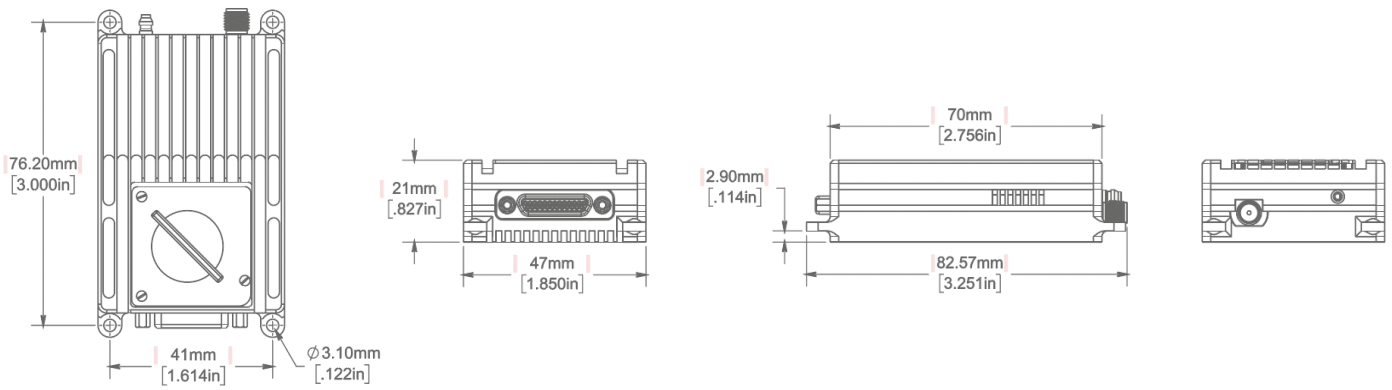



ZPR MODE 5 L2/2-B AND ADS-B RECEIVER

The ZPR is a passive Mode 5 L2/2-B IFF and civil 1090 MHz ADS-B receiver system that provides situational awareness of civil and military aircraft in national airspaces or on the battlefield. The low Size, Weight, and Power Consumption (SWaP) characteristics make ZPR ideal for airborne and shipboard deployments, as well as for temporary or permanent ground-based installation. The system's design is based on hardware and software deployed in the uAvionix AIMS-certified RT-2087/ZPX Mode 5 Micro IFF transponder.



SPECIFICATION	VALUE
Input Voltage/Power	8-32VDC 1W Continuous
Size	83 x 47 x 15 mm
Weight	50 grams
Operating Temp	-45° to 71° C

RECEIVER SENSITIVITY	
ADS-B Rx MDL	-79 dBm ±2 dB
Mode 5 MDL L2/2-B Rx	-84 dBm

ALTIMETER	
Range	-1000 to 126,750 ft

HOST INTERFACE	
Baud Rate	57,600 bps RS-232
Protocol	uAvionix OEM Protocol

POSITION INTERFACE	
Baud Rate	115,200 bps RS-232
Protocol	uAvionix OEM Protocol

TRAFFIC INTERFACE	
Baud Rate	115,200 bps RS-232
Protocol	GDL90+ / DoD AIMS 23-901

KIV INTERFACE	
AIMS 04-900(A)	Option B (KIV-77 / KIV-79)
Crypto Emulator	Internal

OPTIONS	
uAvionix truFYX SIL 3 Position Source	
NSM programming for crypto emulator	

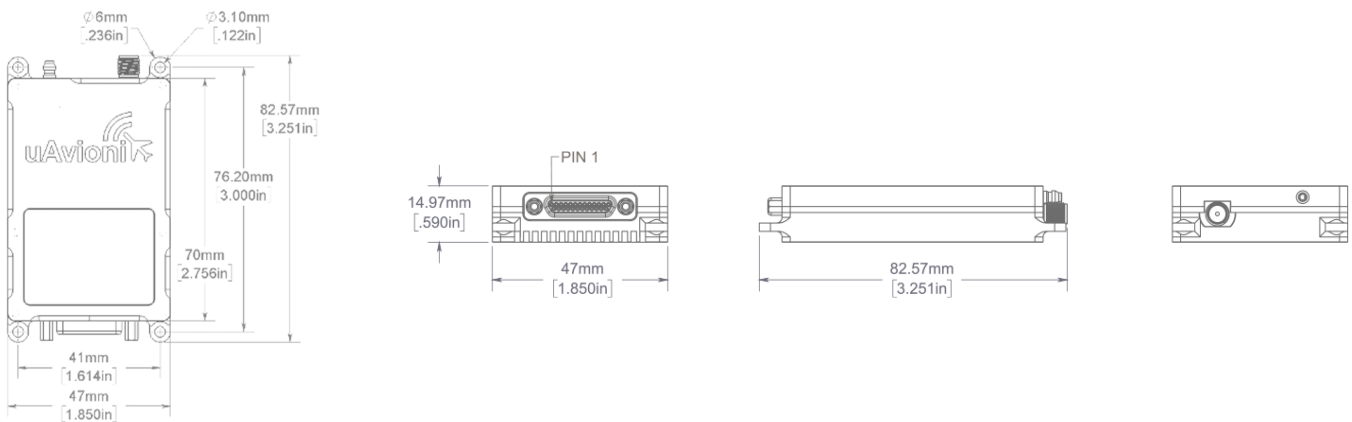



MICRO IFF ACCESSORIES

Mode 5 Crypto Emulators, backplanes, adapters, and antennas provide users of the uAvionix ZP(X/R) family of Micro IFF Mode 5 transponders and receivers with the capability to perform ground and airborne Mode 5 functional testing and verification when crypto keys are unavailable or simply not desired. Using an emulator avoids the burden of dealing with COMSEC security protocols, which often streamlines testing and field operations.

The ZPK line of emulators supports all essential AIMS 04-900(A) Option B functional interface requirements for Mode 5 Interrogator, Transponder, Combined Interrogator-Transponder (CIT), and Combined Transponder Receiver (CTR) applications. Additionally, use of an emulator makes for a convenient path to AIMS 1102 and 1202 unclassified platform testing, enabling dry-runs of test plans in which operational KIVs or keys aren't readily available.

The ZPK emulators are designed for autonomous operation. No external computer or power is required since it's controlled and powered by the transponder with which it's paired. An internal key-fill sequence is initiated after Time-of-Day (TOD) is loaded into the emulator.

In practice, ZPK emulators can be used with Mode 5 Interrogators in unclassified UAS combat or target training. This is easily accomplished by first substituting in each Interrogator a ZPK for the operational KIV normally used, then equipping target platforms with uAvionix ZPX Mode 5 transponders paired with a ZPK emulator.

Backplane and antenna accessories are available off-the-shelf to support the myriad installation possibilities encountered when equipping UAS. These include backplanes for securely coupling the ZP(X/R) with its paired KIV or ZPK, and antennas offering a choice of patterns and gains. Custom wire harnesses to support unique UAS platform installations may be sourced through uAvionix.

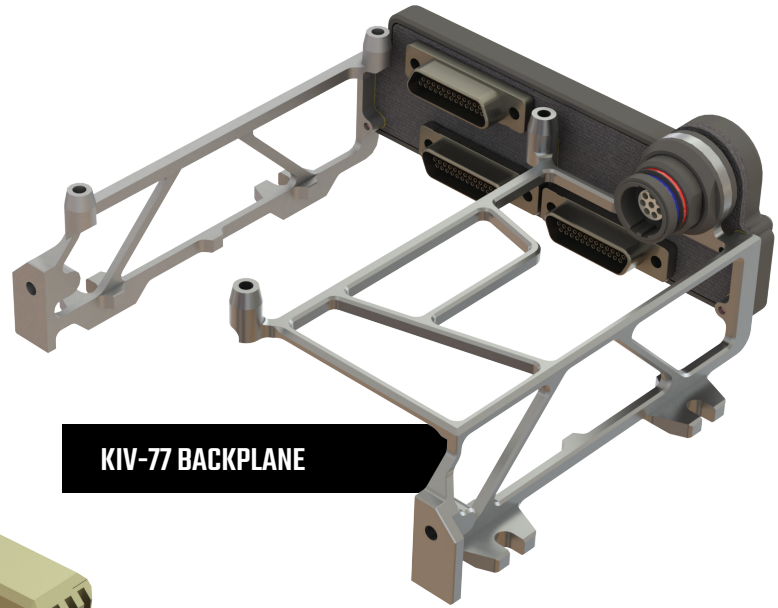

KIV-77 BACKPLANE

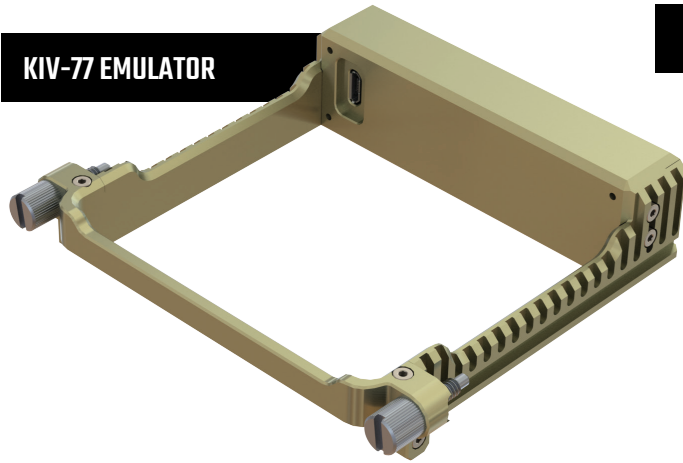

KIV-77 EMULATOR



KIV-79 BACKPLANE

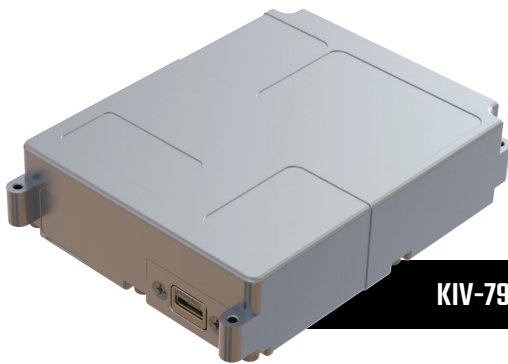

KIV-79 EMULATOR

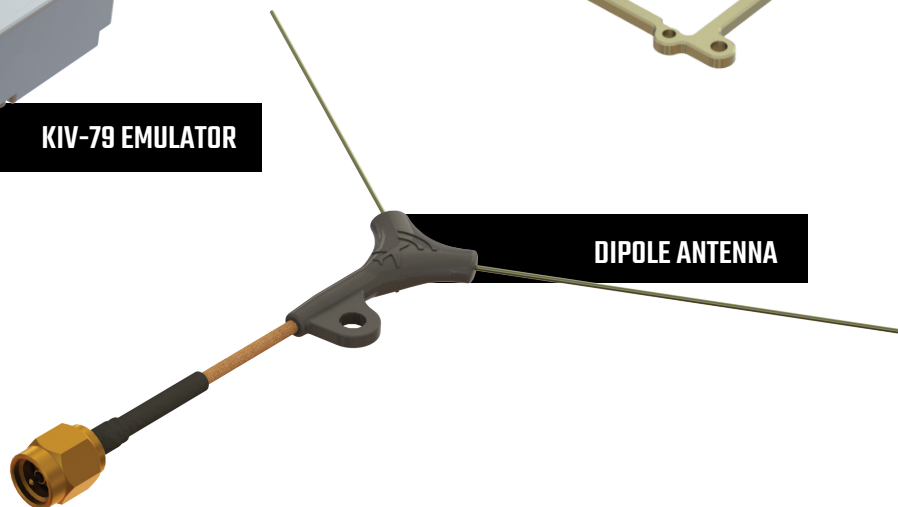

DIPOLE ANTENNA



NOTES

uAvionix

DEFENSE



COPYRIGHT 2025 | ALL RIGHTS RESERVED
uAvionix reserves the right to alter product, services offerings, specifications, and pricing at any time without notice. The appearance of U.S. Department of Defense (DoD) visual information does not imply or constitute DoD endorsement.

IMAGE USED WITH PERMISSION BY TEXTRON SYSTEMS CORPORATION



LEARN MORE AT
[UAVIONIX.COM/DEFENSE](https://uavionix.com/defense)