



# echoESX™ EXP

## User and Installation Guide



© 2025 uAvionix Corporation. All rights reserved.

Except as expressly provided herein, no part of this guide may be reproduced, transmitted, disseminated, downloaded or stored in any storage medium, for any purpose without the express written permission of uAvionix. uAvionix grants permissions to download a single copy of this guide onto an electronic storage medium to be viewed for personal use, provided that the complete text of this copyright notice is retained. Unauthorized commercial distribution of this manual or any revision hereto is strictly prohibited.

uAvionix® and Ping® are registered trademarks of uAvionix Corporation and may not be used without express permission of uAvionix.

ping200X, AV-30-C, AV-30-E, AV-20-E, AV-22-C, beaconX, echoESX and skyBeacon Installer are trademarks of uAvionix Corporation and may not be used without express permission of uAvionix.

Patent [uavionix.com/patents](https://uavionix.com/patents)

# 1 Revision History

Revision	Date	Comments
A	3/26/2025	Initial release

## **2 Warnings / Disclaimers**

All device operational procedures must be learned on the ground.

uAvionix is not liable for damages arising from the use or misuse of this product.

This equipment is classified by the United States Department of Commerce's Bureau of Industry and Security (BIS) as Export Control Classification Number (ECCN) 7A994.

These items are controlled by the U.S. Government and authorized for export only to the country of ultimate destination for use by the ultimate consignee or end-user(s) herein identified. They may not be resold, transferred, or otherwise disposed of, to any other country or to any person other than the authorized ultimate consignee or end-user(s), either in their original form or after being incorporated into other items, without first obtaining approval from the U.S. government or as otherwise authorized by U.S. law and regulations.

### 3 Limited Warranty

uAvionix products are warranted to be free from defects in material and workmanship for one year from the installation of echoESX EXP on the aircraft. For the duration of the warranty period, uAvionix, at its sole option, will repair or replace any product which fails in normal use. Such repairs or replacement will be made at no charge to the customer for parts or labor, provided that the customer shall be responsible for any transportation cost.

Restrictions: This warranty does not apply to cosmetic damage, consumable parts, damage caused by accident, abuse, misuse, fire or flood, theft, damage caused by unauthorized servicing, improper installation or product that has been modified or altered.

Disclaimer of Warranty: IN NO EVENT, SHALL UAVIONIX BE LIABLE FOR ANY INCIDENTAL, SPECIAL, INDIRECT OR CONSEQUENTIAL DAMAGES, WHETHER RESULTING FROM THE USE, MISUSE OR INABILITY TO USE THE PRODUCT OR FROM DEFECTS IN THE PRODUCT. SOME STATES DO NOT ALLOW THE EXCLUSION OF INCIDENTAL OR CONSEQUENTIAL DAMAGES, SO THE ABOVE LIMITATIONS MAY NOT APPLY TO YOU.

Warranty Service: Warranty repair service shall be provided directly by uAvionix. Proof of purchase for the product from uAvionix or authorized reseller is required to obtain and better expedite warranty service.

Please email or call uAvionix support with a description of the problem you are experiencing. Also, please provide the model, serial number, shipping address and a daytime contact number.

You will be promptly contacted with further troubleshooting steps or return instructions. It is recommended to use a shipping method with tracking and insurance.

## 4 Table of Contents

1	Revision History .....	3
2	Warnings / Disclaimers .....	4
3	Limited Warranty .....	5
4	Table of Contents.....	6
5	System Information .....	7
5.1	Performance Standards.....	8
5.1.1	echoESX EXP .....	8
5.2	Deviations and Incomplete .....	8
5.3	FCC ID.....	10
5.4	Device Marking.....	10
5.4.1	echoESX Hardware.....	10
5.4.2	echoESX EXP ADS-B Software .....	10
5.5	Environmental Qualification Form.....	11
5.6	Continued Airworthiness.....	12
5.7	System Limitations .....	12
6	System Specifications.....	13
6.1	System Functionality .....	13
6.2	Call Sign .....	13
6.3	echoESX EXP Specifications .....	13
6.3.1	Physical Specifications.....	13
6.3.2	Mode S Transponder Specifications.....	15
6.3.3	GPS/SBAS Specifications .....	15
6.3.4	Wired Control Interface Specifications .....	15
6.3.5	System Interfaces.....	16
7	Installation.....	17
7.1	Unpacking and Inspecting .....	17
7.2	Authorized Part Numbers .....	17
7.3	Optional Part Numbers .....	17
7.4	Installation Materials and Tools .....	18
7.5	Additional Required Equipment .....	18
7.6	Mounting.....	19
	UAV-1008785-001 .....	6
	Rev A .....	

7.6.1	Transponder Antenna Mounting .....	19
7.6.2	GPS Antenna Mounting.....	19
7.7	Wiring .....	20
8	Control .....	21
9	System Configuration.....	21
10	Normal Operation.....	22
11	Maintenance .....	22
12	Care and Cautions .....	22
13	Support .....	22
Appendix A	Configuring echoUAT for ADS-B IN only.....	23
A.1	echoESX/echoUAT Aircraft Antenna Placement .....	23
A.2	echoUAT Configuration .....	23

## 5 System Information

This installation manual provides mechanical and electrical information necessary to install echoESX EXP. It is not equivalent to an approved airframe-specific maintenance manual, installation design drawing, or installation data package. The content of this manual assumes use by competent and qualified personnel using standard maintenance procedures in accordance with Title 14 of the Code of Federal Regulation and other related accepted procedures. The conditions and tests required for approval of this article are minimum performance standards. Those installing this article either on or within a specific type or class of aircraft must determine that the aircraft installation conditions are within the standards which include any accepted integrated functions not specified by the standards. This is an incomplete system intended to provide the functions identified in, and when installed according to this installation guide.

## 5.1 Performance Standards

### 5.1.1 echoESX EXP

echoESX EXP complies with the following performance standards when properly installed and interfaced with equipment as detailed in this guide.

System Function	RTCA MOPS	Class/Type
Air Traffic Control Radar Beacon System/Mode Select (ATCRBS / Mode S) Airborne Equipment	RTCA/DO-181E	Level 2els, Class 1 <i>[1]</i>
Extended Squitter Automatic Dependent Surveillance – Broadcast (ADS-B) and Traffic Information Service – Broadcast (TIS-B) Equipment Operating on the Radio Frequency of 1090 MHz	RTCA/DO-260B	Class B1S
Airborne Navigation Sensor Using the Global Positioning System (GPS) Augmented by the Satellite Based Augmentation System (SBAS)	RTCA/DO-229E	Beta 1

*[1] Based on the latest RTCA/DO-181F Level 2 Transponder requirements, echoESX does not support the UM protocol, does not support the Comm-A protocol, and does not have the capability to process and transmit air-initiated Comm-B messages. See Section 5.2 for additional details.*

## 5.2 Deviations and Incomplete

MOPS	Deviation
RTCA/DO-181E	<p>Deviation to not implement Utility Message (UM Field) support, consistent with RTCA/DO-181F and FAA/TSO-C112f Level 2 transponder requirements.</p> <p>This impacts the Mode S Level 2 transponder SARPs requirements as contained in ICAO Annex 10 Volume IV §§3.1.2.6.5.3.1, 3.1.2.6.11.3.2.1.3, 3.1.2.6.11.3.4.2.2, and 3.1.2.7.9.2.3.</p>



RTCA/DO-181E	<p>Deviation to not implement Comm-A support, consistent with RTCA/DO-181F and FAA/TSO-C112f Level 2 transponder requirements.</p> <p>This impacts the Mode S Level 2 transponder SARPs requirements as contained in ICAO Annex 10 Volume IV §§2.1.5.1.2, 3.1.2.6.11.1.2, and 3.1.2.10.5.2.1.1.</p>
RTCA/DO-181E	<p>Deviation to not implement broadcast interrogation support, consistent with RTCA/DO-181F and FAA/TSO-C112f Level 2 transponder requirements.</p> <p>This impacts the Mode S Level 2 transponder SARPs requirements as contained in ICAO Annex 10 Volume IV §§2.1.5.1.2, 3.1.2.6.11.1.2, and 3.1.2.10.5.2.1.1.</p>
RTCA/DO-181E	<p>Deviation to not implement multi-site message support, as it applies to the Comm-B operation of Level 2 transponders, consistent with RTCA/DO-181F and FAA/TSO-C112f Level 2 transponder requirements.</p> <p>This impacts the Mode S Level 2 transponder SARPs requirements as contained in ICAO Annex 10 Volume IV §§2.1.5.1.2 and 3.1.2.6.11.3.</p>
RTCA/DO-181E	<p>Deviation to not implement Air-Initiated Comm-B support, consistent with RTCA/DO-181F Level 2 and FAA/TSO-C112f transponder requirements. Air-initiated Comm-B messages are neither processed nor transmitted.</p> <p>This impacts the Mode S Level 2 transponder SARPs requirements as contained in ICAO Annex 10 Volume IV §§2.1.5.1.2 and 3.1.2.6.11.3.</p>
RTCA/DO-181E	<p>Deviation to not reply to ATCBRS/Mode S All-Calls, as required by ICAO Annex 10 Volume IV §3.1.2.1.5.1.1.1 on or after January 1, 2020, and consistent with RTCA/DO-181F and FAA/TSO-C112f requirements.</p>
RTCA/DO-260B	<p>Deviation to not implement Airborne Velocity Subtypes 3 and 4, consistent with RTCA/DO-260C and FAA/TSO-C166c requirements.</p>

RTCA/DO-229E Class Beta 1 functionality is incomplete. echoESX EXP does not implement LNAV approach mode, instead operating in En Route/Terminal mode only, as appropriate for ADS-B Out applications.

### 5.3 FCC ID

Model	FCC ID
echoESX EXP	2AFFTP200S

## 5.4 Device Marking

### 5.4.1 echoESX Hardware

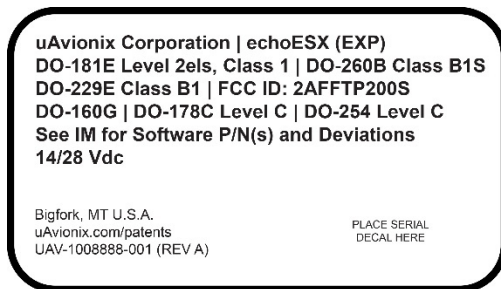

### 5.4.2 echoESX EXP ADS-B Software

The ADS-B software contained in the echoESX EXP is identified by electronic marking.

## 5.5 Environmental Qualification Form

Conditions	DO-160G Section	Description of Conducted Tests
Temperature and Altitude	4.0	Equipment tested to Categories B2,C4
Low temperature ground survival	4.5.1	-55°C
Low Temperature Short-Time Operating	4.5.1	-35°C
Low Temperature Operating	4.5.2	-35°C
High Temperature Operating	4.5.4	+70°C
High Temperature Short-Time Operating	4.5.3	+70°C
High Temperature Ground Survival	4.5.3	+85°C
Loss of Cooling	4.5.5	Cooling air not required (+70°C operating without cooling)
Altitude	4.6.1	24,000 ft
Decompression	4.6.2	Equipment identified as Categories B2,C4 – no test
Overpressure	4.6.3	Equipment identified as Categories B2,C4 – no test
Temperature Variation	5.0	Equipment tested to Category B
Humidity	6.0	Equipment tested to Category A
Operation Shocks	7.0	Equipment tested to Category B
Crash Safety	7.0	Equipment tested to Category B Type 5
Vibration	8.0	Aircraft zone 2: type 5 Category S level M
Explosion	9.0	Equipment identified as Category X – no test
Waterproofness	10.0	Equipment identified as Category X – no test
Fluids Susceptibility	11.0	Equipment identified as Category X – no test
Sand and Dust	12.0	Equipment identified as Category X – no test
Fungus	13.0	Equipment identified as Category X – no test
Salt Spray	14.0	Equipment identified as Category X – no test
Magnetic Field	15.0	Equipment tested to Category Z
Power Input	16.0	Equipment tested to Category BX
Voltage Spike	17.0	Equipment tested to Category B
AF Conducted Susceptibility	18.0	Equipment tested to Category B
Induced Signal Susceptibility	19.0	Equipment tested to Category AC
RF Susceptibility	20.0	Equipment tested to Category TT
RF Emissions	21.0	Equipment tested to Category B
Lightning Induced Transient Susceptibility	22.0	Equipment tested to Category A2XXXX (see Note 1)
Lightning Direct Effects	23.0	Equipment identified as Category X – no test
Icing	24.0	Equipment identified as Category X – no test
Electrostatic Discharge	25.0	Equipment tested to Category A
Fire, Flammability	26.0	Equipment identified as Category X – no test
Notes:		
1. 4-wire serial/power conductors tested to A2XXXX, MMCX GPS conductors tested to A1XXXX		

## 5.6 Continued Airworthiness

Maintenance of the echoESX EXP is "on condition" only.

Periodic regulatory function checks must be performed. The aircraft must be returned to service in a means acceptable to the appropriate aviation authority.

*Note: Transponders certified after January 1, 2020 must not respond to ATCRBS/Mode S All-Calls (Long P4 interrogation). This may cause unexpected results to be obtained by transponder test sets.*

*Note: Mode S transponders must only respond to Mode S Only All-Calls when airborne. echoESX EXP can be placed in an airborne state for test purposes by entering Ground Test Mode "BeaconX GTM" on the AV-30-E and AV-20-E.*

## 5.7 System Limitations

### SatCom

The echoESX EXP GPS has not been demonstrated as compatible with SatCom equipment and should not be installed on SatCom equipped aircraft.

*Note 1: SatCom equipment is defined as radio transmitters transmitting on or near the L1/L2 frequency bands. This does not include passive receive-only systems such as additional GPS receivers or unidirectional satellite data link receivers.*

## 6 System Specifications

### 6.1 System Functionality

echoESX EXP is a complete Mode S Extended Squitter (ES) ADS-B OUT transponder, integrated with an internal SBAS/WAAS. It is designed to meet the transponder and ADS-B requirements for operating in controlled airspace worldwide, while minimizing installation costs.

### 6.2 Call Sign

Your aircraft tail number/N-number, as configured on the AV-30-E/AV-20-E installation menu, will be used as the call sign. If a pilot enters a Flight ID in-flight (e.g. NGF6873), the Flight ID field will be used as the call sign instead of the N-number. This allows your call sign to be configured to correspond with ATC communications and flight plans, for use during commercial, medical, or volunteer flight operations.

 When configuring your tail number for U.S. registered aircraft, ensure the leading “N” is included.

### 6.3 echoESX EXP Specifications

#### 6.3.1 Physical Specifications

Characteristics	Specifications
Width	103.00mm
Height	36.00mm
Depth	100.61mm
Weight	6.17 oz (175 grams)
Operating temperature range	-35°C to +70°C
Maximum pressure altitude	24,000ft
Input voltage range	9 to 30.3 VDC
14V current	0.16A idle 0.25A maximum
28V current	0.13A idle 0.20A maximum

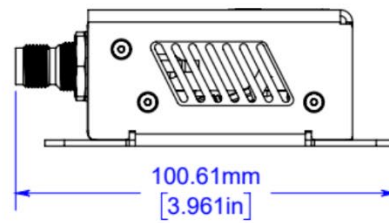
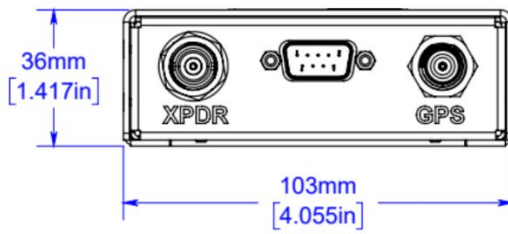
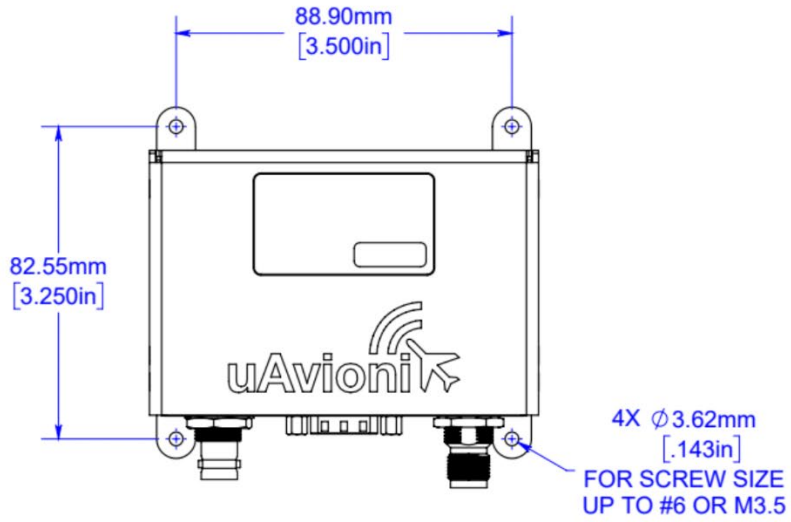

### 6.3.2 Mode S Transponder Specifications

Characteristics	Specifications
Transmit frequency	1090 MHz
Transmit power	54dBm (250W)
Receive frequency	1030 MHz
ATCRBS sensitivity	-74 dBm
Mode S sensitivity	-74 dBm
RF Impedance	50 $\Omega$
RF Connector	SMA

### 6.3.3 GPS/SBAS Specifications

Characteristics	Specifications
Number of channels	15 (12 GPS and 3 GPS/SBAS)
Frequency	1575.42 MHz L1, C/A code
Sensitivity	
Tracking	-166 dBm
Reacquisition	-160 dBm
Cold Start	-148 dBm
Hot Start	-160 dBm
Horizontal position accuracy	5 m RMS with SBAS
Velocity accuracy	3 m/s
TTF (Time to First Fix)	58 seconds typical with current almanac and position
Reacquisition	1 second typical
Position update interval	0.2 second (5 Hz)
Time mark	$\pm 30$ ns of UTC
Datum	WGS-84
GNSS Altitude output	Height Above Ellipsoid (HAE)
SDA (System Design Assurance)	2
SIL (Source Integrity Level)	3

### 6.3.4 Wired Control Interface Specifications

Characteristics	Specifications
Physical	RS-232
Rate and properties	2400 bps 8N1

### 6.3.5 System Interfaces

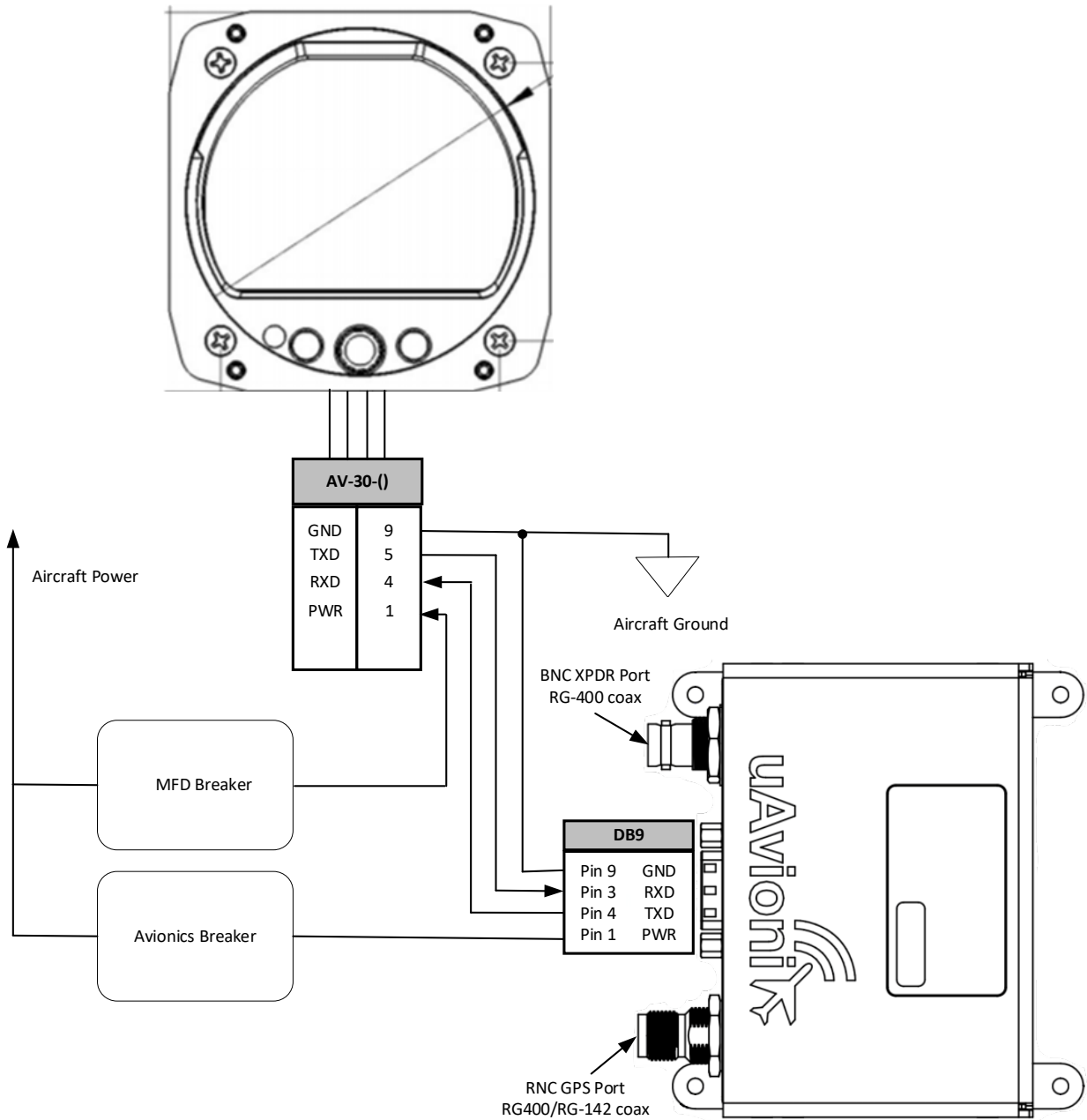



## 7 Installation

### 7.1 Unpacking and Inspecting

Carefully unpack the device and make a visual inspection of the unit for evidence of any damage incurred during shipment. If the unit is damaged, notify the shipping company to file a claim for the damage. To justify your claim, save the original shipping container and all packing materials.

### 7.2 Authorized Part Numbers

Item	P/N
echoESX EXP Hardware	UAV-1008885-( )
echoESX Software	UAV-1002393-( )

### 7.3 Optional Part Numbers

Item	P/N
uAvionix Mode S 1090Mhz Monopole Antenna	UAX-90125-01
uAvionix ESX GPS Antenna (TSO-C190)	UAX-90124-01

## 7.4 Installation Materials and Tools

In addition to the available installation kit(s), echoESX EXP may require standard aviation parts for installation. Parts may include:

- RG-400 coax between the echoESX EXP XPDR port and the Mode S 1090Mhz antenna
- RG-400 or RG-142 coax between the echoESX EXP GPS port and the GPS antenna
- Shielded wire
- Circuit breakers
- Environmental splices
- Ring terminals for grounding
- Thread locking compound.

Minimally, echoESX EXP installation requires access to the following tools:

- Phillips screwdriver
- 1.5mm hex driver (included)
- Appropriate crimping tool(s)

## 7.5 Additional Required Equipment

echoESX EXP is a “remote” transponder; to function it requires connection to a controlling device such as an AV-30-E or AV-20-E. The following table details what functions are provided directly by echoESX EXP.

Transponder	ADS-B Transmitter	GPS Receiver	Transponder Antenna	GPS Antenna	Control Head w/ Annunciation	Altitude Encoder
X	X	X				

In typical configurations, the AV-30-E/AV-20E provides control, display, annunciation, and pressure altitude information.

## 7.6 Mounting

echoESX EXP provides mounting tabs for easy installation in the cabin/fuselage areas. It's recommended to mount the echoESX EXP as close to the transponder antenna as reasonable to minimize the RG-400 cable loss. It should be mounted in a location that minimizes vibration and moisture.

### 7.6.1 Transponder Antenna Mounting

The 1090Mhz transponder antenna should be installed in the same aircraft location as the previously installed Mode A/C transponder's antenna. Typically, this is on the belly of the aircraft facing downward.

### 7.6.2 GPS Antenna Mounting

echoESX EXP is compatible with DO-301/TSO-C190 GPS antennas accepting a 5VDC bias voltage for active antenna operation. The GPS antenna should be mounted on the fuselage of the aircraft facing skyward with an unobstructed view of the sky during level flight.

It is best practice to have at least 4 feet of separation from any other transmitting antenna.

#### 7.6.2.1 uAvionix ESX GPS Antenna Mounting

uAvionix recommends installation of the uAvionix ESX GPS Antenna shown below with the echoESX EXP.



Figure 7-1 uAvionix ESX GPS Antenna UAX-90124-01

- Ensure the aircraft installation location has optimal sky view and is located at least 4 feet from other on-board transmit antennas.

- Using the provided template, drill 4 holes for the #6-32 screws and a center hole for the TNC connector.
- Screw the antenna assembly to the aircraft.
- uAvionix recommends installing RTV sealant over the screw heads and around the base of the antenna/aircraft interface.

## 7.7 Wiring

echoESX EXP requires connections to power, ground, and an RS-232 control interface.

DB9 Pin	Type	Function
1	Power	Aircraft Power
3	Input	RS-232 Receive
4	Output	RS-232 Transmit
9	Power	Aircraft Ground

Refer to AC 43.13-1B Chapter 11 for guidance on appropriate wire and sizes. The wiring should present an impedance of less than 0.5ohm. The following table provides guidance for typical aircraft wire installation.

Gauge	ohm/km	Maximum Length for 0.5ohm
20 AWG	35	14.2m
22 AWG	64	7.8m

## **8 Control**

echoESX EXP requires serial connection to either a uAvionix AV-30-E or AV-20-E. It retrieves transponder control (Stby, On, ALT and IDENT) and pressure altitude information from the AV-20-E or AV-30-E. Status and annunciation information regarding the echoESX EXP is displayed on the AV-30-E/AV-20-E.

## **9 System Configuration**

Refer to the AV-30-E or AV-20-E Installation Manual for guidance on configuring the echoESX.

## **10 Normal Operation**

echoESX EXP must be enabled, typically in ALT mode, during all phases of flight including surface movement operations.

## **11 Maintenance**

The echoESX EXP is not a user serviceable product. All service must be performed either by uAvionix or an authorized uAvionix repair center.

## **12 Care and Cautions**

## **13 Support**

For additional questions or support please visit:

<https://www.uavionix.com/support/>

## Appendix A Configuring echoUAT for ADS-B IN only

This appendix provides instructions for uAvionix customers who are upgrading from an echoUAT to echoESX EXP. Since echoESX EXP does not provide ADS-B IN, it's recommended that customers utilize their legacy echoUAT for ADS-B IN functionality. The following instructions detail how to configure the echoUAT for ADS-B IN only.

### A.1 echoESX/echoUAT Aircraft Antenna Placement

#### A.1.1 ADS-B Antenna Placement

Typical echoUAT users will have 2 monopole antennas located on the belly of their aircraft.

- The 1090Mhz monopole antenna location that was formerly connected to the replaced (legacy) Mode A/C transponder should now be connected to the echoESX EXP.
- The echoUAT monopole antenna should remain the same.

#### A.1.2 GPS Antenna Placement

The echoESX EXP and echoUAT GPS antennas are not compatible. Each device requires its own GPS antenna.

- echoESX EXP GPS antenna should be installed on the fuselage facing skyward.
- The echoUAT GPS antenna should remain in the same location.

### A.2 echoUAT Configuration

Ensure the echoUAT has the latest software found on the uAvionix Service Bulletin [here](#).

echoUAT Software Device	Latest Software Version
PC-1	0.4.6
PT-2	2.4.66

1. Connect the echoUAT to the Echo smartphone app. See [echoUAT User and Installation Guide Revision Rev P](#) Section 10 for details.

- From the Configuration page, finger tap 3 times on the logo  in the upper left corner of the screen to unlock the “ADVANCED” tab.

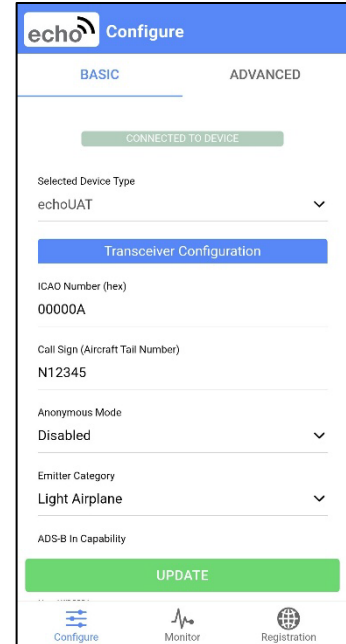

- From the ADVANCED tab, select the Control dropdown and choose “RX only”.

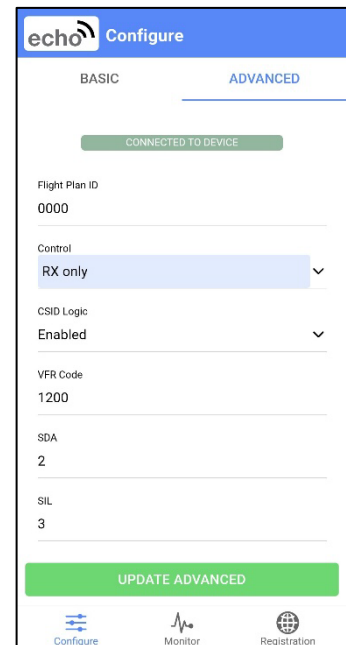

- Press the green UPDATE ADVANCED button at the bottom of the screen.
- Now the echoUAT will be used as an ADS-B IN device only.