



Ping200Sr

User and Installation Guide



© 2019 uAvionix Corporation. All rights reserved.

uAvionix Corporation
300 Pine Needle Lane
Bigfork, MT 59911

<http://www.uavionix.com>

support@uavionix.com

Except as expressly provided herein, no part of this guide may be reproduced, transmitted, disseminated, downloaded or stored in any storage medium, for any purpose without the express written permission of uAvionix. uAvionix grants permissions to download a single copy of this guide onto an electronic storage medium to be viewed for personal use, provided that the complete text of this copyright notice is retained. Unauthorized commercial distribution of this manual or any revision hereto is strictly prohibited.

uAvionix® and Ping® are registered trademarks of uAvionix Corporation and may not be used without express permission of uAvionix.

Patent uavionix.com/patents

1 Revision History

Revision	Date	Comments
A	12/9/2017	Initial release
B	1/19/2018	Updated Markings for ping200Sr
C	8/22/2018	Updated mode commands
D	10/26/2019	Configuration updates
E	11/25/2019	Update markings and language

2 Warnings / Disclaimers

All device operational procedures must be learned on the ground.

uAvionix is not liable for damages arising from the use or misuse of this product.

-  **This equipment has received a FAA transmit license for manned aircraft and a license for un-manned aircraft operating above 500ft AGL**

-  **The antenna used for this transmitter must be installed to provide a separation distance of at least 20 cm from all persons.**

This equipment is classified by the United States Department of Commerce's Bureau of Industry and Security (BIS) as Export Control Classification Number (ECCN) 7A994.

These items are controlled by the U.S. Government and authorized for export only to the country of ultimate destination for use by the ultimate consignee or end-user(s) herein identified. They may not be resold, transferred, or otherwise disposed of, to any other country or to any person other than the authorized ultimate consignee or end-user(s), either in their original form or after being incorporated into other items, without first obtaining approval from the U.S. government or as otherwise authorized by U.S. law and regulations.

3 Limited Warranty

uAvionix products are warranted to be free from defects in material and workmanship for one year from purchase. For the duration of the warranty period, uAvionix, at its sole option, will repair or replace any product which fails in normal use. Such repairs or replacement will be made at no charge to the customer for parts or labor, provided that the customer shall be responsible for any transportation cost.

Restrictions: This warranty does not apply to cosmetic damage, consumable parts, damage caused by accident, abuse, misuse, fire or flood, theft, hangar rash, damage caused by unauthorized servicing, or product that has been modified or altered.

Disclaimer of Warranty: IN NO EVENT, SHALL UAVIONIX BE LIABLE FOR ANY INCIDENTAL, SPECIAL, INDIRECT OR CONSEQUENTIAL DAMAGES, WHETHER RESULTING FROM THE USE, MISUSE OR INABILITY TO USE THE PRODUCT OR FROM DEFECTS IN THE PRODUCT. SOME STATES DO NOT ALLOW THE EXCLUSION OF INCIDENTAL OR CONSEQUENTIAL DAMAGES, SO THE ABOVE LIMITATIONS MAY NOT APPLY TO YOU.

Warranty Service: Warranty repair service shall be provided directly by uAvionix. Proof of purchase for the product from uAvionix or authorized reseller is required to obtain and better expedite warranty service.

Please email or call uAvionix support with a description of the problem you are experiencing. Also, please provide the model, serial number, shipping address and a daytime contact number.

You will be promptly contacted with further troubleshooting steps or return instructions. It is recommended to use a shipping method with tracking and insurance.

4 Contents

1	Revision History.....	3
2	Warnings / Disclaimers.....	4
3	Limited Warranty.....	5
5	Introduction.....	8
5.1	Description.....	8
5.2	Interfaces.....	9
5.3	Software and Airborne Electronic Hardware Configuration.	10
5.4	Supplied Accessories.....	10
6	Technical Specifications.....	11
6.1	Markings.....	12
7	Equipment Limitations.....	12
7.1	Installation.....	12
7.1.1	Modifications and Use Outside of Intended Scope.....	12
8	Equipment Installation.....	13
8.1	Unpacking and Inspecting.....	13
8.2	Mounting.....	13
8.3	Connections.....	14
8.4	Wiring Diagram.....	16
8.5	Cooling Requirements.....	18
8.6	Antenna Installation.....	18
9	Programming.....	19
9.1	Default Control.....	20
9.2	ICAO Number.....	20
9.3	Callsign.....	21
9.4	Aircraft Category.....	21
9.5	VFR Squawk Code.....	21
9.6	Aircraft Maximum Speed.....	21

9.7	ADS-B RX Capability	21
9.8	Aircraft Length / Width	22
9.9	GPS Antenna Offset Lateral / Longitudinal.....	23
10	PC Control Application.....	24
11	Post Installation Checks.....	25
12	Continued Airworthiness	26
13	Environmental Qualification Forms	27

5 Introduction

5.1 Description

The Ping200Sr is a DO-181E, Mode S, Level 2els, Class 1 transponder with support for ADS-B extended squitter. The Ping200Sr has a nominal power output of 250W and meets the power output requirements for Class 1. The ADS-B function meets DO-260B class B1S. The integrated GPS sensor meets the requirements of DO-229D.

Meets the requirements of:

RTCA/DO-181E Level 2els Class 1

RTCA/DO-260B Class B1S

RTCA/DO-229D Class Beta 1 (Ping200Sr only)

SAE/AS8003

RTCA/DO-178C Level C

RTCA/DO-254 Level C

RTCA/DO-160G

ICAO Annex 10, Volume IV

This transponder replies to both legacy Mode A/C interrogations and to Mode S interrogations from both ground radar and airborne collision avoidance systems. In all cases, the interrogations are received by the transponder on 1030MHz and replies are transmitted on 1090MHz.

The base model Ping200S has an integrated altitude sensor. Ping200Sr has an integrated altitude sensor, GPS sensor and remote GPS antenna.

5.2 Interfaces

The Ping200Sr has a single SMA antenna connection, a 6-pin Control interface and a 4-pin programming interface.

Host Interface

	Protocol	Message Type
CONTROL COM RX 1200-115200bps	GDL90 Appendix A	[^CS] Callsign [^MD] Mode
	SAGETECH	[0x02] Preflight [0x03] Operating [0x05] Data Request
POSITION COM RX <i>(Ping200S Only)</i>	SAGETECH	[0x04] GPS Data
	Protocol	Message Type
STATUS COM TX 1200-115200bps	GLD90 Appendix B	[0 ₁₀] Heartbeat [10 ₁₀] Ownship [11 ₁₀] Geo Altitude
	SAGETECH	[0x80] Acknowledge [0x81] Installation Response [0x82] Preflight Response [0x83] Status Response

The Interface Control Document (ICD) can be downloaded from:

<https://uavionix.com/>

5.3 Software and Airborne Electronic Hardware Configuration.

Part	Part Number	Revision
Software	UAV-1000704-001	A
Airborne Electronic Hardware	UAV-1000706-001	A

5.4 Supplied Accessories

Part	Part Number	Revision
Ping200S	UAV-1000706-001	
Ping200Sr	UAV-1001096-001	
Antenna Monopole		
Antenna Dipole		
PingProg		
Programming Cable JST5p-4p		
Power/Control Cable Molex6p		
RS232-USB adapter		

6 Technical Specifications

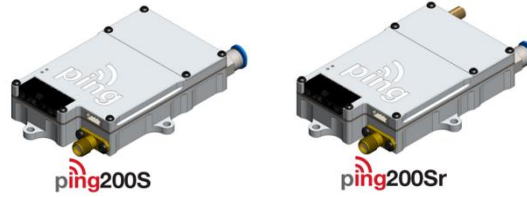

Operating Altitude	unrestricted	unrestricted
Max Cruising Speed	unrestricted	unrestricted
Transmit Power (Max)	54dBm, 250W	54dBm, 250W
1030 Receive Sensitivity	-74±3 dBm	-74±3 dBm
RF Impedance	50Ω	50Ω
Host Serial Communications	SageTech, GDL90	SageTech, GDL90
Calibrated Pressure Altitude	85,000 ft	85,000 ft
Export Compliance	ECCN 7A994	ECCN 7A994
Supply Voltage	11-33V	11-33V
Power Consumption (ON & ALT)	2W	2W
Power Consumption (STBY)	1W	1W
Transponder Performance Standard	RTCA/DO-181E	RTCA/DO-181E
Class	1	1
Level	2els	2els
ADS-B Performance Standard	RTCA/DO-260B	RTCA/DO-260B
Class	B1S	B1S
Pressure Altitude Standard	SAE/AS8003	SAE/AS8003
Meets the Performance of (FAA TSO authorization not granted)	TSO-C112e (Mode S) TSO-C166b (ADS-B) TSO-C88b (Alt Encoder)	TSO-C112e (Mode S) TSO-C166b (ADS-B) TSO-C199 (GPS) TSO-C88b (Alt Encoder)
Environmental	RTCA/DO-160G	RTCA/DO-160G
FCC ID	2AFFTP200S	2AFFTP200S
FAA Transmit License	Manned aircraft. Unmanned operating above 500ft AGL.	Manned aircraft. Unmanned operating above 500ft AGL.
Software	RTCA/DO-178C Level C	RTCA/DO-178C Level C
Hardware	RTCA/DO-254 Level C	RTCA/DO-254 Level C
Operating Temperature	-45°C to +70°C	-45°C to +70°C
Storage Temperature	-55°C to +85°C	-55°C to +85°C
Transmitter Modulation	6M75 V1D	6M75 V1D
Weight	73 grams	76 grams
Height	17mm	17mm
Length	90.8mm	90.8mm
Width	56.5mm	56.5mm
Host Interface Connector	Molex 0436450600	Molex 0436450600
RF Connector	SMA	SMA
External GPS Antenna Connector		MCX
Pressure Altitude Connector	3mm FESTO	3mm FESTO

6.1 Markings

ping200S

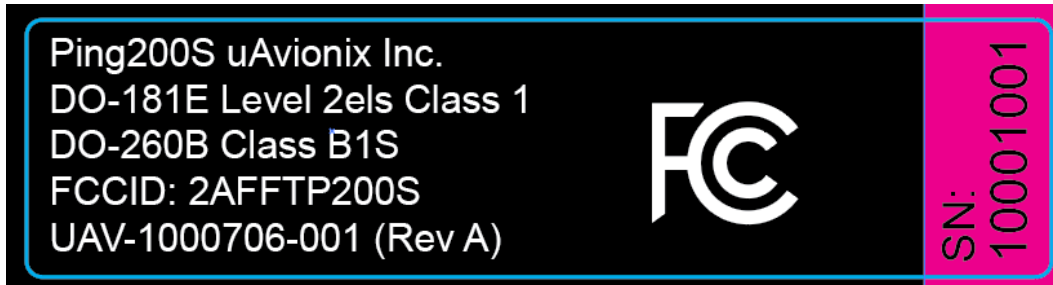

ping200Sr



7 Equipment Limitations

7.1 Installation

7.1.1 Modifications and Use Outside of Intended Scope

This device has been designed and tested to conform to all applicable standards in the original form and when configured with the components shipped with the device. It is not permissible to modify the device, use the device for any use outside of the intended scope, or use the device with any antenna other than the one shipped with the device.

8 Equipment Installation

This section describes the installation of Ping200Sr and related accessories in the aircraft, including mounting, wiring, and connections.

8.1 Unpacking and Inspecting

Carefully unpack the device and make a visual inspection of the unit for evidence of any damage incurred during shipment. If the unit is damaged, notify the shipping company to file a claim for the damage. To justify your claim, save the original shipping container and all packing materials.

8.2 Mounting

The Ping200Sr is designed to be mounted in any convenient location in the cockpit, the cabin, or an avionics bay.

The following installation procedure should be followed, remembering to allow adequate space for installation of cables and connectors.

- Select a position in the aircraft that is not too close to any high external heat source. The Ping200Sr is not a significant heat source itself and does not need to be kept away from other devices for this reason.
- Avoid sharp bends and placing the cables too near to the aircraft control cables.
- Secure the transponder to the aircraft via the three (3) mounting holes. It should be mounted on a flat surface.

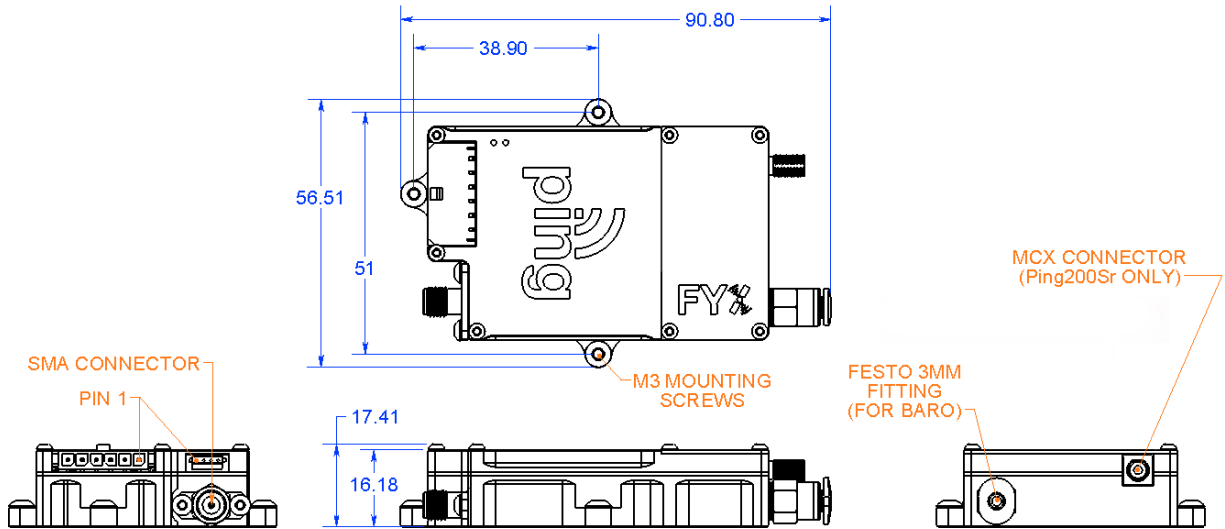

8.3 Connections

! Whenever power is supplied to the transponder, a 50ohm load must be provided to the SMA connection. You can use the supplied antenna or a commercially available 50ohm load.

Powering the transponder without an attached load will result in damage to the device not covered under warranty.

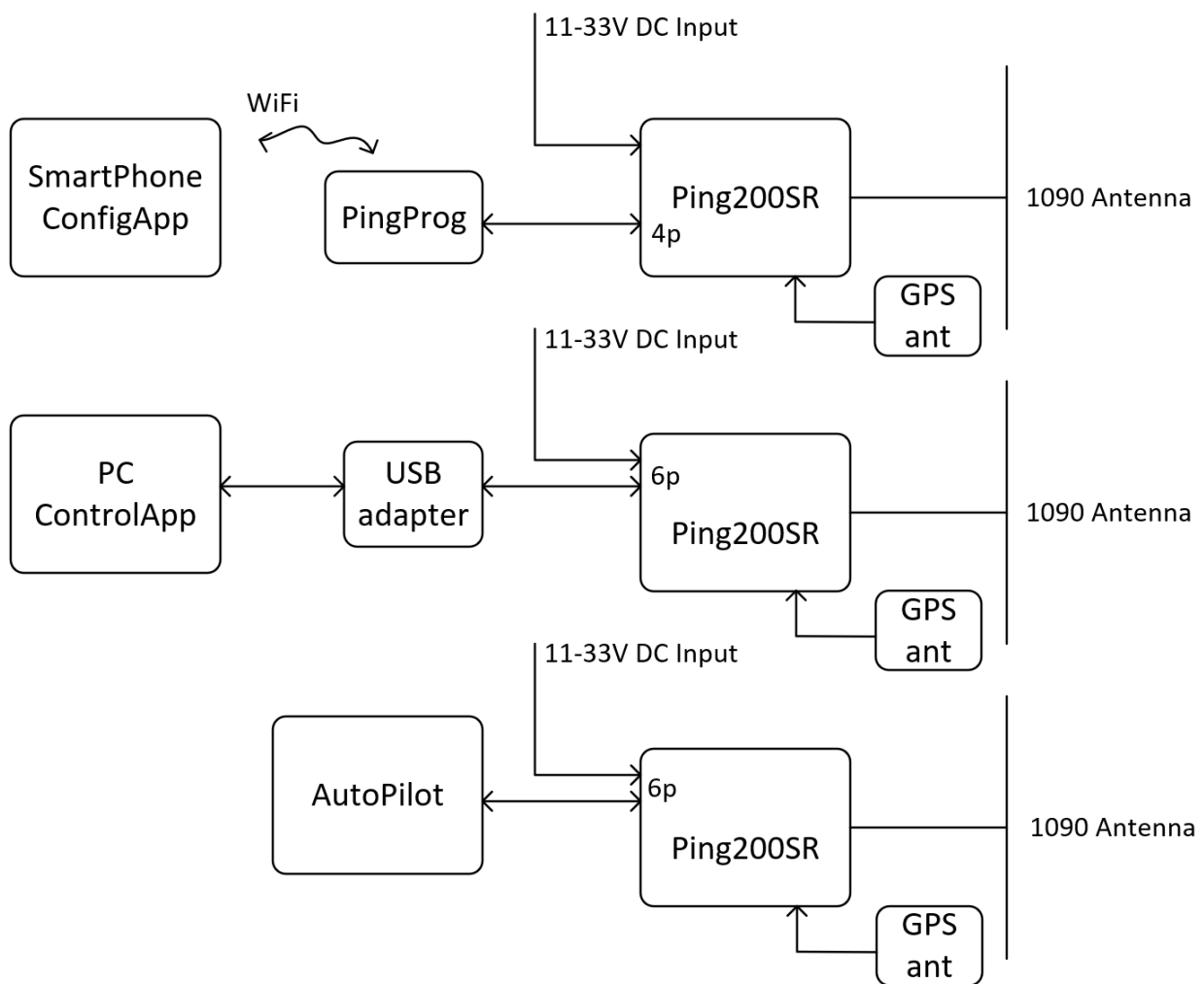

8.4 Wiring Diagram

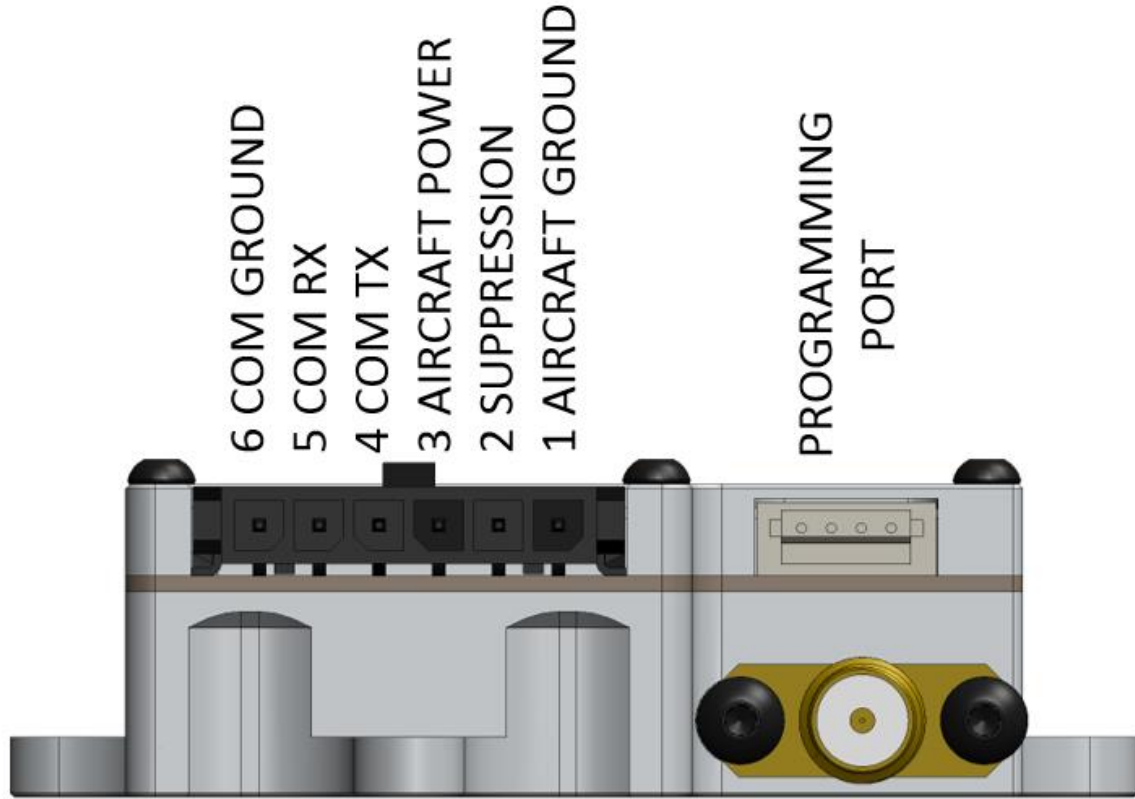

SMA ANTENNA

MCX GPS ANTENNA

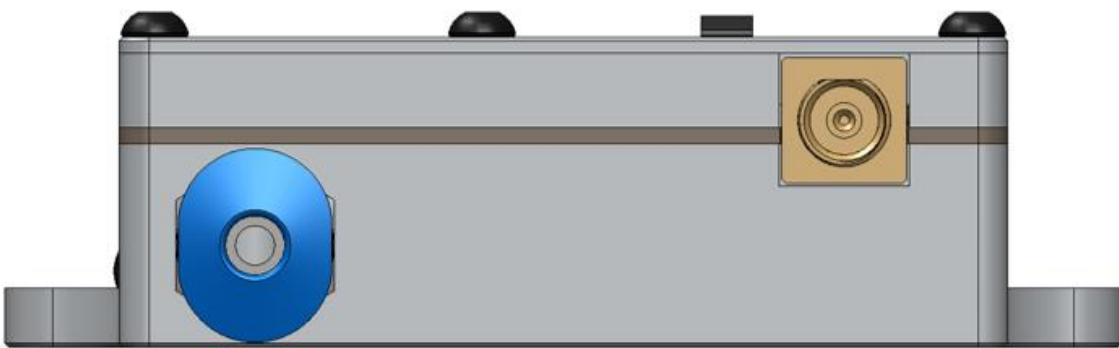

FESTO 3mm STATIC PORT

Control Interface

Pin	Type	Physical	Rate
1	Ground		
2	NC		
3	Aircraft Power	11-33V	
4	COM TX	RS-232 Out	Programmable
5	COM RX	RS-232 In	Programmable
6	RS232 Ground		
Mating Connector: Molex 0436450600, Pins: 0462350001			

Transponder LEDs

LED	SOLID	FLASHING
RED	FAULT	Reply / Transmit
GREEN	Powered	Receiving Interrogation

8.5 Cooling Requirements

Ping200Sr is designed to meet all applicable TSO requirements without forced-air cooling.

Attention should, however, be given to the incorporation of cooling provisions to limit the maximum operating temperature if Ping200Sr is installed in close proximity to other Avionics. The reliability of equipment operating in close proximity in an avionics bay can be degraded if adequate cooling is not provided.

8.6 Antenna Installation

The following considerations should be taken into account when siting the antenna.

- The antenna should be mounted in a vertical position when the aircraft is in level flight.
- Avoid mounting the antenna within 1 meter of the ADF sense antenna or any COMM antenna and 2 meters from the transponder to the DME antenna.
- Where practical, plan the antenna location to keep the cable lengths as short as possible and avoid sharp bends in the cable to minimize the Voltage Standing Wave Ratio (VSWR).

Electrical connection to the antenna should be protected to avoid loss of efficiency due to exposure to liquids and moisture. All Antenna feeders shall be installed in such a way that a minimum of RF energy is radiated inside the aircraft.

9 Programming

These settings are stored in the Ping200Sr. To change these settings, the Ping200Sr is configured via the supplied PingUSB Wi-Fi adapter and mobile device application.



The transponder system should be configured during initial system installation by a qualified technician. The configuration items list below should be used to document the system installation for future reference.

Configuration Item		Default	Control Priority
Default Control		Standby/Off	YES
ICAO Number		0x000000	
Callsign		“ “	YES
Aircraft Category		UAV (14)	
VFR Squawk Code		1200	YES
Aircraft Maximum Speed		Not Available	
ADS-B RX Capability	UAT RX	NO	
	ES1090 RX	NO	
Aircraft Length (Meters)		0	
Aircraft Width (Meters)		0	
GPS Offset Lateral (Meters)		0	
GP Offset Longitudinal (Meters)		0	

Configuration Items List

9.1 Default Control

Select the desired control type. This setting configures the Ping200Sr for Standby, On or Altitude reporting.

- Standby/Off: Disables both the transmit and receive functions.
- ON: Responds to all interrogations and transmits ADS-B Extended Squitter messages. Reports 0000 to altitude (Mode C) interrogations.
- ALT: Responds to all interrogations and transmits ADS-B Extended Squitter messages. Reports barometric altitude to Mode C interrogations.

9.2 ICAO Number

The ICAO address is a 24-bit number issued to the aircraft by the registration authority of the aircraft. These addresses are usually written as a 6-digit hexadecimal number, although you may also encounter one
UAV-1000711-001 Rev E

written as an 8-digit octal number. The Ping200Sr understands the hexadecimal format. An octal number must be converted to hexadecimal format before entering.

Tip: By using the N-Number Look Up function on <https://www.faa.gov>, locate and use the “Mode S Code (base 16 / hex)” value. Applies to U.S. registered aircraft only.

9.3 Callsign

The CALL SIGN can be up to an 8 alpha-numeric code that corresponds to the tail number of the aircraft. (0-9, A-F).

Note: This is typically your aircraft N-number, unless otherwise advised by the FAA or ATC.

9.4 Aircraft Category

To assist ATC tracking of aircraft, an aircraft category can be transmitted.

9.5 VFR Squawk Code

VFR squawk (Mode 3/A) code is a pre-programmed default code when the pilot is flying VFR and not in contact with ATC. In the USA, the VFR squawk code is 1200 and in most parts of Europe the VFR squawk code is 7000.

9.6 Aircraft Maximum Speed

Mode S transponders can transmit their maximum airspeed characteristics to aircraft equipped with TCAS. This information is used to identify threats and to plan avoiding action by the TCAS equipped aircraft. The airspeeds are grouped in ranges.

9.7 ADS-B RX Capability

The ADS-B transmissions include an indication to the ground stations of whether the aircraft includes a 1090MHz ADS-B receiver, a UAT ADS-B receiver, or both.

9.8 Aircraft Length / Width

When on the ground, ADS-B transmits encoded aircraft size information which is used by ATC to identify taxiing routes and potential conflicts. Enter the length and width (wingspan) fields and the appropriate size codes will be calculated for transmission.

Air Aircraft Length in Meters	Aircraft Width (wing span) in Meters
$L \leq 15$	$W \leq 23$
$15 < L \leq 25$	$28.5 < W \leq 34$
$25 < L \leq 35$	$33 < W \leq 38$
$35 < L \leq 45$	$39.5 < W \leq 45$
$45 < L \leq 55$	$45 < W \leq 52$
$55 < L \leq 65$	$59.5 < W \leq 67$
$65 < L \leq 75$	$72.5 < W \leq 80$
$75 < L \leq 85$	$W > 80$
$L > 85$	Any

9.9 GPS Antenna Offset Lateral / Longitudinal

The GPS antenna offset is used in conjunction with the length and width to manage taxiway conflicts. A typical GPS does not report the geographic position of the center of the aircraft, or even the tip of the nose of the aircraft; instead, it usually reports the location of the actual GPS antenna (not the GPS receiver). In normal flight operation, this distinction is of no importance at all, but if ADS-B is used to manage taxiway conflicts, a significant offset in antenna position could mean the aircraft footprint is not in the same place as the ADS-B reported position. Although the GPS Antenna Offset is primarily intended for position correction on large transport aircraft, General Aviation aircraft can also have a significant offset. For example, if the aircraft has a long tail boom and the GPS antenna is on top of the tail, the GPS position could be 4 meters or more from the nose of the aircraft.

GPS Antenna Lateral Offset from roll axis (Meters)	GPS Antenna Longitudinal Offset from aircraft nose (Meters)
0	0 to 60 Meters in 2 Meter increments
Left 2	
Left 4	
Left 6	
Right 2	
Right 4	
Right 6	

10 PC Control Application

A PC example control application is available to operate the control interface. Use the supplied USB adapter to connect the Control Interface to a PC. Set the Port to the USB serial port and the App Baud to 57600.

Callsign, Mode and Squawk can be set in the application. The Ownship Display can monitor the programmed ICAO, Emitter category and GPS position.

The control app can be downloaded from:

<https://uavionix.com/>

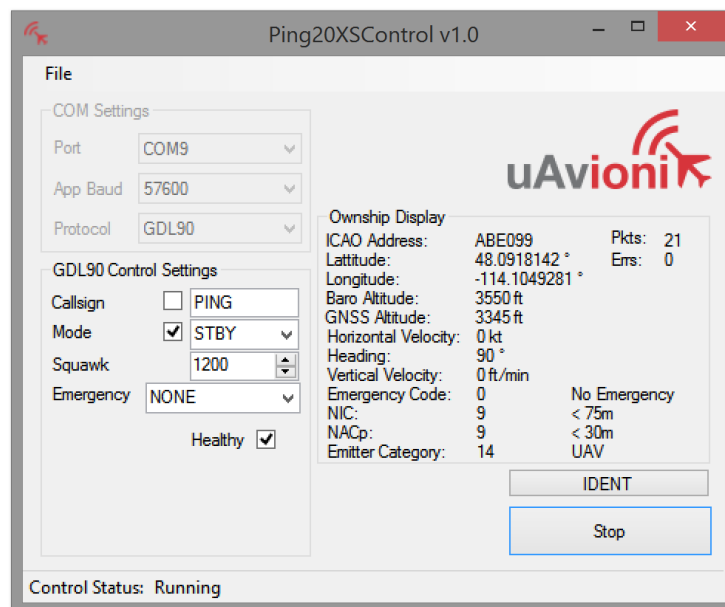

11 Post Installation Checks

Connect the system as shown in the Post Installation configuration diagram.

STEP	CHECK
Launch the PC Ping20XSControl application	
Set Port to the USB or serial port connected to the Ping200Sr	
Set the App Baud to 57600	
Set Protocol to GDL90	
Connect the Antenna	
Apply power from a minimum of a 12V, 3A power source	
Confirm that the Green LED comes on after power-up	
'Pkts:' should start counting confirming that the app is talking to the transponder	
Confirm 'ICAO Address' is correctly programmed and not 000000	
Confirm 'Baro Altitude' is correct for your field elevation	
After the GPS has had time to lock, confirm that 'Latitude' and 'Longitude' are correct	
Set 'Mode' to 'ALT' and check the 'Mode' box	
Observe the Red LED flashing about four times a second. This indicates 1090ES ADS-B transmissions	
If you are in range of Radar, the Green LED will flash during interrogations	
Using an EFB App such as ForeFlight mobile. Connect via WiFi to PingUSB powered by a portable USB 5V power supply.	
The separation between the transponder and programmer needs to be at least 500ft	
The aircraft will appear as traffic on the EFB application	

12 Continued Airworthiness

Other than for periodic functional checks required by the regulations, Ping200Sr has been designed and manufactured to allow “on condition maintenance”. This means that there are no periodic service requirements necessary to maintain continued airworthiness, and no maintenance is required until the equipment does not properly perform its intended function. When service is required, a complete performance test should be accomplished following any repair action. Repairs should only be carried out in accordance with uAvionix service procedures.

13 Environmental Qualification Forms

Nomenclature	Ping200Sr ADS-B Mode S transponder	
Part No: UAV-1000706-001	DO-181E, Mode S, Level 2els, Class 1 transponder	
Manufacturer	uAvionix Inc	
Address	300 Pine Needle Lane Bigfork, MT 59911	
Conditions	DO-160G Section	Description of Conducted Tests
Temperature and Altitude	4.0	Equipment tested to Category B2
Low temperature ground survival	4.5.1	-55°C
Low Temperature Short-Time Operating	4.5.1	-45°C
Low Temperature Operating	4.5.2	-45°C
High Temperature Operating	4.5.4	+70°C
High Temperature Short-Time Operating	4.5.3	+70°C
High Temperature Ground Survival	4.5.3	+85°C
Loss of Cooling	4.5.5	Cooling air not required (+70°C operating without cooling)
Altitude	4.6.1	35,000feet
Decompression	4.6.2	Equipment identified as Category B2 – no test
Overpressure	4.6.3	Equipment identified as Category B2 – no test
Temperature Variation	5.0	Equipment tested to Category B2
Humidity	6.0	Equipment tested to Category B2
Operation Shocks	7.2	Equipment tested to Category B
Crash Safety	7.3	Equipment tested to Category B type 5
Vibration	8.0	Aircraft zone 2: type 3, 4, 5 to Category S level M, type 1 (Helicopters) to Category U level G
Explosion	9.0	Equipment identified as Category X – no test
Waterproofness	10.0	Equipment identified as Category X – no test
Fluids Susceptibility	11.0	Equipment identified as Category X – no test
Sand and Dust	12.0	Equipment identified as Category X – no test
Fungus	13.0	Equipment identified as Category X – no test
Salt Spray	14.0	Equipment identified as Category X – no test
Magnetic Field	15.0	Equipment identified as Category Z
Power Input	16.0	Equipment identified as Category ZX
Voltage Spike	17.0	Equipment identified as Category B
AF Conducted Susceptibility	18.0	Equipment identified as Category B
Induced Signal Susceptibility	19.0	Equipment identified as Category AC
RF Susceptibility	20.0	Equipment identified as Category TT
RF Emissions	21.0	Equipment identified as Category B
Lightning Induced Transient Susceptibility	22.0	Equipment identified as Category XXXX – no test
Lightning Direct Effects	23.0	Equipment identified as Category X – no test
Icing	24.0	Equipment identified as Category X – no test
Electrostatic Discharge	25.0	Equipment identified as Category X – no test
Fire, Flammability	26.0	Equipment identified as Category C

Appendix A. GDL 90 Compatible Control Protocol Format (Control RX - RS-232 57600bps, N81)

The Ping200Sr receives control messages over the Control interface. The interface uses an ASCII-text basis, with an ASCII-encoded hexadecimal checksum. The checksum is algebraic sum of the message byte values. Messages are delimited with a carriage return character.

A1. Physical Interface

The Control interface uses RS-232 signaling levels. The port is configured for the following characteristics:

- Baud Rate: 57600 baud
- Start Bits: 1
- Data Length: 8
- Stop Bits: 1
- Parity: None
- Flow Control: None

A2. Control Messages

The following table summarizes the Control messages that the Ping200Sr receives.

Msg ID	Description	Notes	Ref
^CS	Call Sign	1 min interval or on change	A2.1
^MD	Operating Mode Message	1 second interval (nominal)	A2.2

A2.1 Call Sign Message

The Call Sign message provides for a user selectable callsign.

Rate: Every 1 minute or when a change occurs
Message Length: 15 bytes

Byte	Contents	Description
1	^	ASCII '^' (0x5E)
2	C	ASCII 'C' (0x43)
3	S	ASCII 'S' (0x53)
4		ASCII space (0x20)
5-12	ddddddd	ASCII Flight ID (all 8 characters are mandatory, right pad with space)
13-14	dd	Checksum of bytes 1 through 12. In hex ASCII i.e. "FA"
15	\r	ASCII carriage return (0x0D)

Example: ^CS UAVIONIX87\r

A2.2 Mode Message

The mode message indicates the current operating mode. It includes the current mode, the Ident status, current squawk code setting and emergency code.

Rate: 1 sec (nominal)
 Message Length: 17 bytes

Byte	Contents	Description
1	^	ASCII '^' (0x5E)
2	M	ASCII 'M' (0x4D)
3	D	ASCII 'D' (0x44)
4		ASCII space (0x20)
5	m	See mode field table below
6	,	ASCII comma (0x2C)
7	I	See ident field table below
8	,	ASCII comma (0x2C)
9-12	dddd	ASCII squawk code
13	e	See emergency field table below
14	h	Health bit in hex ASCII "1"
15-16	dd	Checksum of bytes 1 through 14. In hex ASCII i.e. "FA"
17	\r	ASCII carriage return (0x0D)

Mode Field

m	Definition	ASCII
O	OFF/STBY	0x4F
A	ON	0x41
C	ALT	0x43
S	ALT	0x53
E	1090ES Only	0x45

Ident Field

i	Definition	ASCII
I	Ident Enabled	0x49
-	Ident is Inactive	0x2D

Emergency Field

e	Definition	ASCII
0	None	0x00
1	General	0x01
2	Medical	0x02
3	Fuel	0x03
4	Com	0x04
5	Hijack	0x05
6	Downed	0x06
7	UAS Lost Link	0x07

The health indication is set to '1' to indicate that everything is operating normally.

Example: ^MD A,I,23540120\r

Mode ON, Ident active, Squawk 2354, No Emergency, Healthy

Appendix B. GDL 90 Ownship Protocol Format.
(Control TX RS-232 57600bps, 81N)

The GDL 90 Data Interface Specification can be found at:

https://www.faa.gov/nextgen/programs/adsb/Archival/media/GDL90_Public_ICD_RevA.PDF

Ping200Sr transmits the following messages:

Msg ID	Description	Notes	Ref
0 ₁₀	Heartbeat	1 second interval	§3.1
10 ₁₀	Ownship Report	1 second interval	§3.4
11 ₁₀	Ownship Geometric Report	1 second interval	§3.8