

Overview

ping200XR is a complete system designed to meet the Transponder and Automatic Dependent Surveillance – Broadcast (ADS-B) requirements for operating Unmanned Aviation Systems (UAS) in controlled airspace. The system is fully configurable as any combination of Mode A, Mode C, Mode S transponder and Extended Squitter ADS-B transmitter. The ping200XR includes a barometric sensor with accuracy beyond 60,000ft and a (TSO) certified SBAS Global Positioning System (GPS) position source designed specifically for Unmanned Aircraft Systems (UAS) (DO-229e).



TSO Certification Pending (TSOA Q4 2022)

- TSO-C88b internal altitude sensor
- TSO-C112e Level 2els, Class 1 Mode S transponder
- TSO-C166b Class B1S Extended Squitter transmitter
- TSO-C145e Class Beta-1 GPS
- Configurable, non-TSO variant available as Modes A/C only, Mode S only, ES only, Modes A/C + ES, Mode S + ES, and Modes A, C, S + ES
- Meets the U.S. ADS-B Out equipment performance requirements of 14 CFR 91.227
- Static pressure sensor accurate to 60,000ft.
- GDL90+ ownship and altitude packets
- SMA 1030/1090MHz Antenna Connector

Conformity

- DO-181E Level 2els, Class 1
- DO-260B Class B1S
- DO-178C Level C
- DO-254 Level C
- DO-160G
- DO-229E Class Beta-1
- SAE/AS8003

Regulatory

- FAA transmit license - manned aircraft and unmanned aircraft operating above 500ft AGL
- FCC 47 CFR Part 87 ID 2AFFTP200S

Technical Specifications

Specification	Value
Input Power	11-34V (3S-8S LiPo) 1.5W Continuous On/Alt. 4W Peak (8ms maximum)
Size	47x72x10mm
Weight	52 grams
SIL/SDA	3/2
Operating Temp	-35 to 70°C
Transponder	
MTL 1030MHz	-74dBm ±3dB
1090 Transmit Power	250W Nominal
Position Engine	
GPS L1C/A w. SBAS	12 GPS Channel 3 SBAS Channels
HPA / VPA	5m / 7m
Velocity Accuracy	3 m/s
Time Accuracy	30 ns
Update Rate	5 Hz
SIL/SDA	3/2
Acquisition Sensitivity	-148 dBm
Tracking Sensitivity	-167 dBm
Altimeter	
Range	-1000 to 35,000ft – TSO-compliant 35,000 to 60,000ft - ±1% Accuracy Non-TSO – 80,000ft
Interfaces	
Baudrate	1,200-115,200bps
Protocol	GDL90+
Options	
1030/1090MHz Transponder Antenna Includes GNSS antenna, may utilize third party DO-301 (or equivalent) GNSS antennas with a 5VDC bias	

Electrical Specification

Interface

Pin	Type	Physical	Protocol
Black	22AWG	Aircraft Ground	
Red	22AWG	Aircraft Power	
Orange	24AWG	AP RXD	GDL90+
Gray	24AWG	AP TXD	GDL90+

Environmental

Condition	DO-160G	Category
Temperature	4.0	B2, C4
Temperature Variation	5.0	B
Humidity	6.0	A
Operational Shock	7.0	B
Vibration	8.0	Aircraft zone 2: type 5 Category S level M
Magnetic Field	15.0	Y
Power Input	16.0	BX
Voltage Spike	17.0	B
AF Conducted Susceptibility	18.0	B
Induced Signal Susceptibility	19.0	AC
RF Susceptibility	20.0	TT
RF Emissions	21.0	B
Lightning Induced Transient Susceptibility	22.0	A2XXXX - 4 Wires A1XXXX - MMCX
ESD	25.0	A

Mechanical Specification

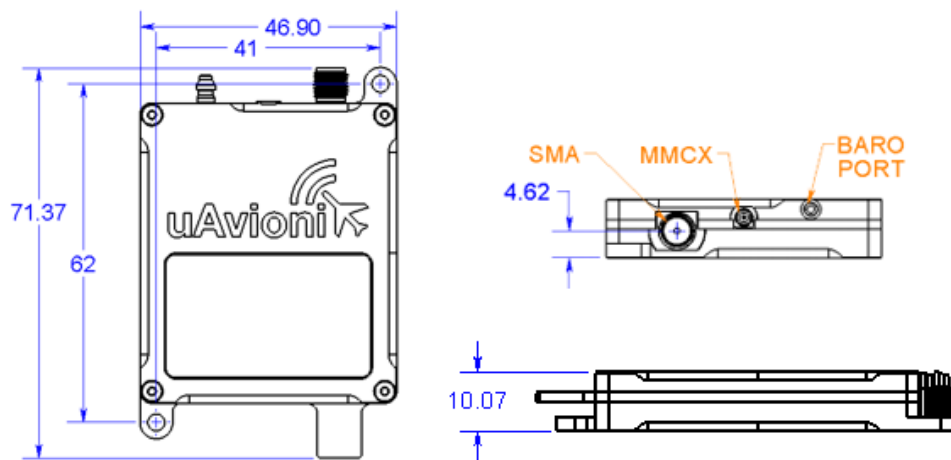

! Whenever power is supplied to the transponder, a 50ohm load must be provided to the SMA connection. You can use the supplied antenna or a commercially available 50ohm load.

Powering the transponder without an attached load will result in damage to the device not covered under warranty.

nano Control Head

