



VTU-20

User and Installation Guide



© 2019 - 2022 uAvionix Corporation. All rights reserved.

uAvionix Corporation

300 Pine Needle Lane.

Bigfork, MT 59911

<http://www.uavionix.com>

support@uavionix.com

Except as expressly provided herein, no part of this guide may be reproduced, transmitted, disseminated, downloaded or stored in any storage medium, for any purpose without the express written permission of uAvionix. uAvionix grants permissions to download a single copy of this guide onto an electronic storage medium to be viewed for personal use, provided that the complete text of this copyright notice is retained. Unauthorized commercial distribution of this manual or any revision hereto is strictly prohibited.

uAvionix® is a registered trademark of uAvionix Corporation, and may not be used without express permission of uAvionix.

VTU-20 is a trademark of uAvionix Corporation and may not be used without express permission of uAvionix.

1 Revision History

Revision	Date	Comments
A	1/7/2019	Initial release
B	3/4/2019	Updated self-test LED description and mounting information Update configuration instructions
C	3/14/2019	Add part numbers Updated wiring harness information Updated installation text and screenshots
D	12/2/2019	Updated product diagrams Included documentation for optional VTU cap
E	2/24/2022	Update part numbers, installation and grounding guidance

2 Warnings / Disclaimers

All device operational procedures must be learned when not in motion.

uAvionix is not liable for damages arising from the use or misuse of this product.

This equipment is classified by the United States Department of Commerce's Bureau of Industry and Security (BIS) as Export Control Classification Number (ECCN) 7A994.

These items are controlled by the U.S. Government and authorized for export only to the country of ultimate destination for use by the ultimate consignee or end-user(s) herein identified. They may not be resold, transferred, or otherwise disposed of, to any other country or to any person other than the authorized ultimate consignee or end-user(s), either in their original form or after being incorporated into other items, without first obtaining approval from the U.S. government or as otherwise authorized by U.S. law and regulations.

3 Limited Warranty

uAvionix products are warranted to be free from defects in material and workmanship for two years from the installation in the vehicle. For the duration of the warranty period, uAvionix, at its sole option, will repair or replace any product which fails under normal use. Such repairs or replacement will be made at no charge to the customer for parts or labor, provided that the customer shall be responsible for any transportation cost.

Restrictions: This warranty does not apply to cosmetic damage, consumable parts, damage caused by accident, abuse, misuse, water, fire or flood, lightning, damage caused by unauthorized servicing, or product that has been modified or altered without the express written consent of uAvionix.

Disclaimer of Warranty: IN NO EVENT, SHALL UAVIONIX BE LIABLE FOR ANY INCIDENTAL, SPECIAL, INDIRECT OR CONSEQUENTIAL DAMAGES, WHETHER RESULTING FROM THE USE, MISUSE OR INABILITY TO USE THE PRODUCT OR FROM DEFECTS IN THE PRODUCT. SOME STATES DO NOT ALLOW THE EXCLUSION OF INCIDENTAL OR CONSEQUENTIAL DAMAGES, SO THE ABOVE LIMITATIONS MAY NOT APPLY TO YOU.

Warranty Service: Warranty repair service shall be provided by the reseller of the product. Please contact your reseller with a description of the problem you are experiencing. Also, please provide the model, serial number, shipping address and a daytime contact number.

You will be promptly contacted with further troubleshooting steps or return instructions. It is recommended to use a shipping method with tracking and insurance.

4 Table of Contents

1	Revision History.....	3
2	Warnings / Disclaimers	4
3	Limited Warranty.....	5
4	Table of Contents	6
5	Introduction.....	7
6	Features and Specifications.....	7
6.1	Mechanical Enclosures	8
6.2	Technical Parameters	10
6.2.1	Physical Specifications	10
6.2.2	GPS/SBAS Specifications	10
6.2.3	978MHz UAT Specifications.....	11
7	Installation	11
7.1	Hardware Part Numbers	11
7.2	Software Part Numbers.....	12
7.3	Mounting.....	12
7.3.1	Fixed / Penetration Mounting.....	12
7.3.2	Magnetic Mounting (Optional).....	14
7.3.3	In-Cab Controller Mounting	15
7.4	Connection to the Vehicle Electrical System	15
7.5	Routine Inspection	17
8	Squitter Maps	17
9	Configuration	18
9.1	Device Configuration.....	18
9.2	Squitter Map Installation.....	21
9.3	Squitter Map Removal	23
10	Normal Operation	25

11	Warranty Conditions	26
12	Environmental Qualification Forms	27

5 Introduction

The uAvionix VTU-20 is a UAT ADS-B squitter device designed specifically for installation and use on vehicles operating inside an airfield and the aircraft movement area. VTU-20 is compliant with FAA Advisory Circular 150/5220-26 with Change 3 and FAA-E-3032.

Installation is simple with included magnetic mounting hardware for temporary or non-penetrating positions, or as a hard-mounted unit to the vehicle's roof structure. With a simple wiring harness that allows for permanent connections to the vehicle 12VDC electrical system, and an in-cab controller and display device, the unit can be installed and configured in minutes on any commercial, industrial or military vehicle.

VTU-20 provides improved visibility by controllers of the position of vehicles at airfields equipped with multilateration, ADS-B and primary radar systems by more accurately providing the position of the vehicle and the identification/call sign on the controller's surface display.

6 Features and Specifications

- SBAS-enabled GPS receiver
 - Meets performance of TSO-C145d Class Beta 1
- UAT (978 MHz) transmitter (16W)
 - Meets performance of TSO-C154c Class B2 as modified by power levels in FAA-E-3032
- Low power consumption
- IP67 enclosure
- Magnetic or fixed/penetration mounting
- Field configurable through PC configuration utility

6.1 Mechanical Enclosures

VTU-20 consists of an exterior enclosure with integrated antenna assembly, and an in-cab controller. The exterior enclosure can be hard mounted or magnetically mounted.

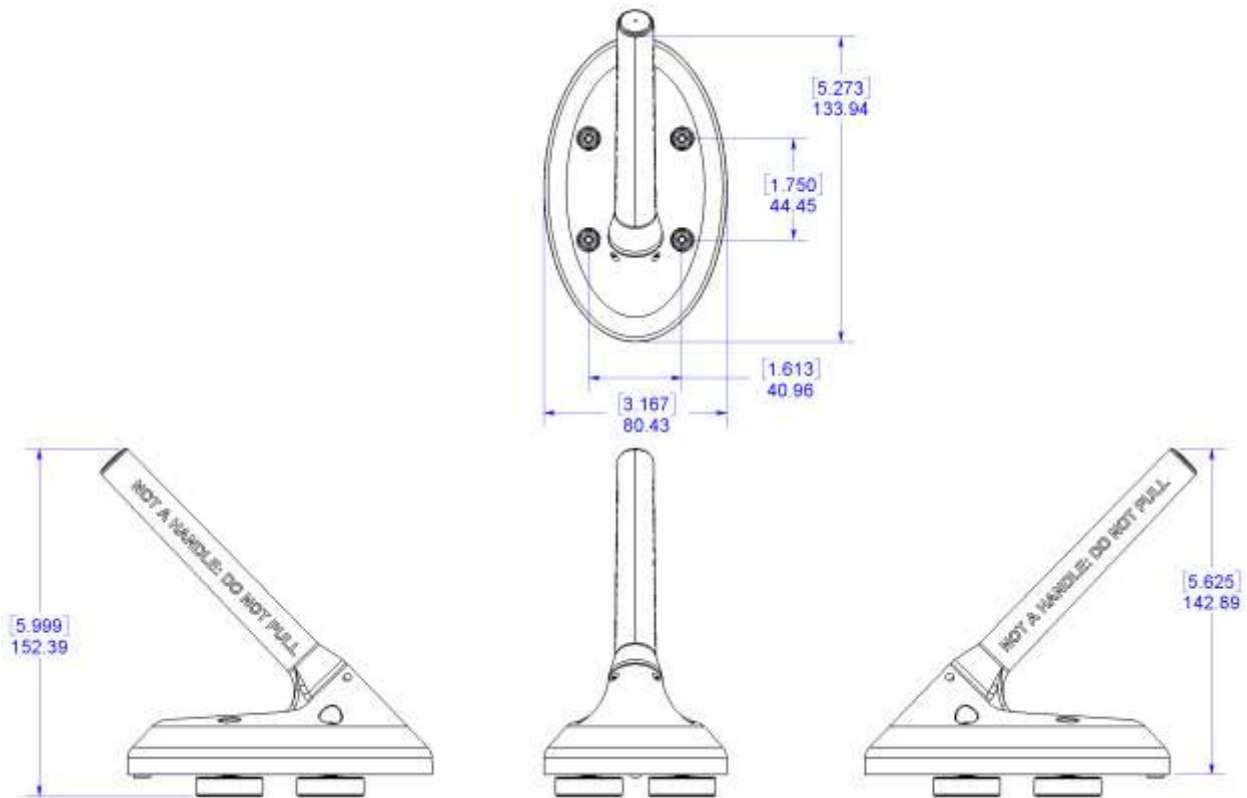

Figure 6-1 Exterior Enclosure Drawing

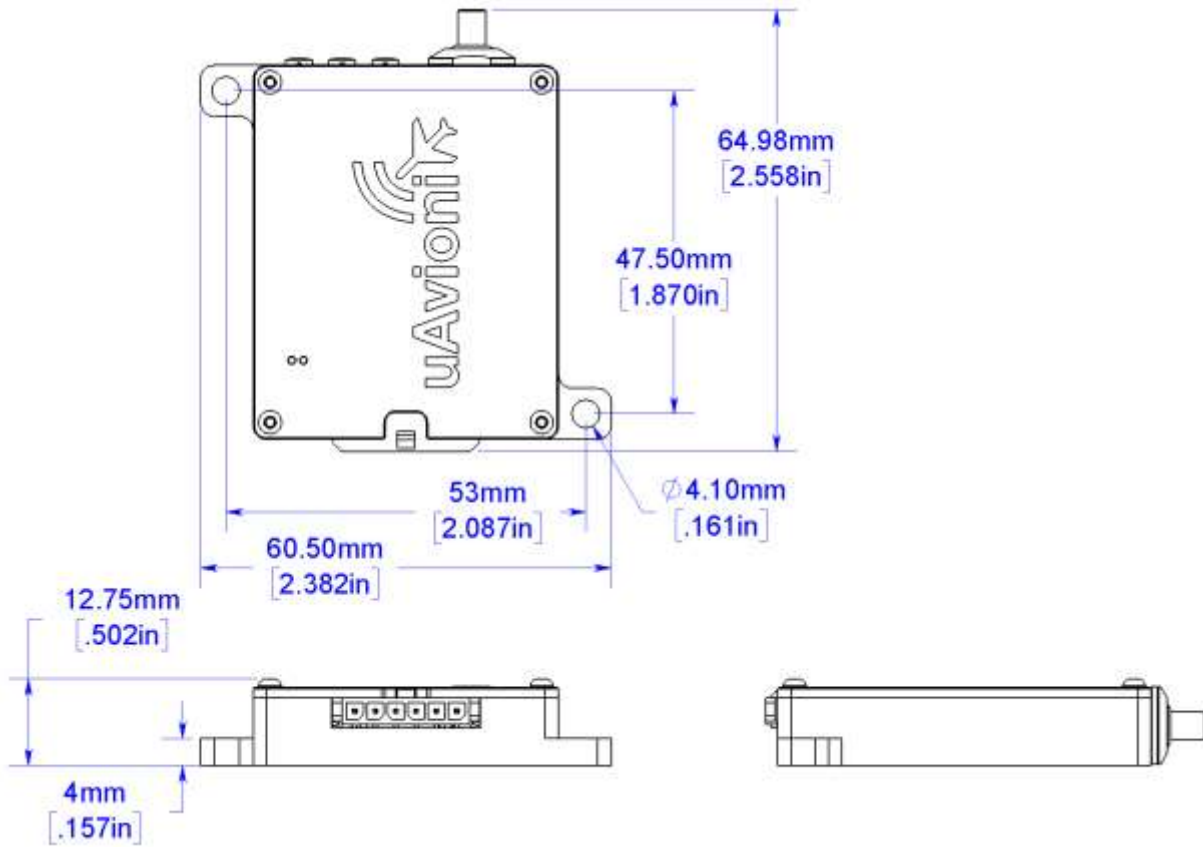

Figure 6-2 In-Cab Controller Drawing

6.2 Technical Parameters

The VTU-20 meets the requirements of FAA-E-3032 “Vehicle Automatic Dependent Surveillance Broadcast (ADS-B) Specification” and FAA/AC 150/5220-26. It is listed as qualified product by FAA/AC 150/5220-26 Change 3 and higher.

6.2.1 Physical Specifications

Characteristics	Specifications
Dimensions	134 x 138 x 80mm
Weight	150g
Operating Temperature Range	-45°C to +70°C
Input Voltage Range	9 to 32 VDC
14V Current	0.5A Max
28V Current	0.25A Max
Interface	RS-232 serial
Serviceability	Firmware upgradable over serial

6.2.2 GPS/SBAS Specifications

Characteristics	Specifications
Number of Channels	15 (12 GPS and 3 GPS/SBAS)
Frequency	1575.42 MHz L1, C/A code
Sensitivity	
Tracking	-166 dBm
Reacquisition	-160 dBm
Cold Start	-148 dBm
Hot Start	-160 dBm
Horizontal position accuracy	6 m RMS with SBAS
Velocity accuracy	0.05 m/s
Heading accuracy	0.3 degrees
TTF (Time to First Fix)	58 seconds typical with current almanac and position
Reacquisition	1 second typical
Position update interval	0.2 second (5 Hz)
Time Mark	±20 nSec of UTC
Datum	WGS-84

6.2.3 978MHz UAT Specifications

Characteristics	Specifications
Frequency	978.00 MHz
Transmit Power	42 dBm (16 W)
Frequency Tolerance	±10 PPM
Modulation	Continuous phase FSK, h = 0.6, raised cosine, a = 0.5
Data Rate	1.041667 Mbps
99% Power Bandwidth	1.3 MHz
60dB bandwidth	3.3 MHz
Transmission Line Impedance	50 ohm
Antenna Polarization	Vertical

7 Installation

7.1 Hardware Part Numbers

Item	P/N
VTU-20 Exterior Enclosure (EE)	UAV-1001253-()
VTU-20 In-Cab Controller (ICC)	UAV-1001834-()
VTU-20 Configuration Harness	UAV-1002582-001
VTU-20 Installer Software	UAV-1002778-001
VTU-20 EE Mounting Plate Set (Optional)	UAX-90043-06
VTU-20 Extension Cable, M8 x 3m	UAX-90043-10
VTU-20 Extension Cable, M8 x 5m	UAX-90043-09
VTU-20 Extension Cable, M8 x 10m	UAX-90043-07
VTU-20 Magnet Kit (Optional)	UAX-90043-05

If additional connectors are required, refer to the table below for industry (COTS) part numbers.

Item	P/N
Molex Pin Crimps	0430300002
Molex 6 Pin (ICC)	436450608
Norcomp M8-style Connector (EE to ICC)	Various

7.2 Software Part Numbers

Item	P/N
ICC PF007 Operating Program	UAV-1002408-()
EE PF007 Operating Program	UAV-1001759-()
EE GPS Operating Program	UAV-1002029-()

7.3 Mounting

VTU-20 EE *must* be mounted according to Section 7.3.1 or 7.3.2. Mounting with epoxy, zip ties or other methods that may degrade over time is not approved.

7.3.1 Fixed / Penetration Mounting

VTU-20 has been designed to allow for permanent installation on the surface of a vehicle and for all wiring to be introduced through the interior of the passenger compartment.

Identify the best suited location for the unit. Per FAA-E-3032, the Exterior Enclosure should be installed on the “exterior top” of the vehicle. To minimize unnecessary wind loading of the unit, align the unit to the front of the vehicle or the primary direction of travel. In addition, to ensure GPS accuracy and minimize time to position lock, the unit should have a clear line of sight to the sky. To mitigate reflections or blocking of 978 MHz transmissions, the unit should be a minimum of 6 inches from other roof mounted equipment such as warning lights, and 24 inches from other radio frequency emitting antennas.

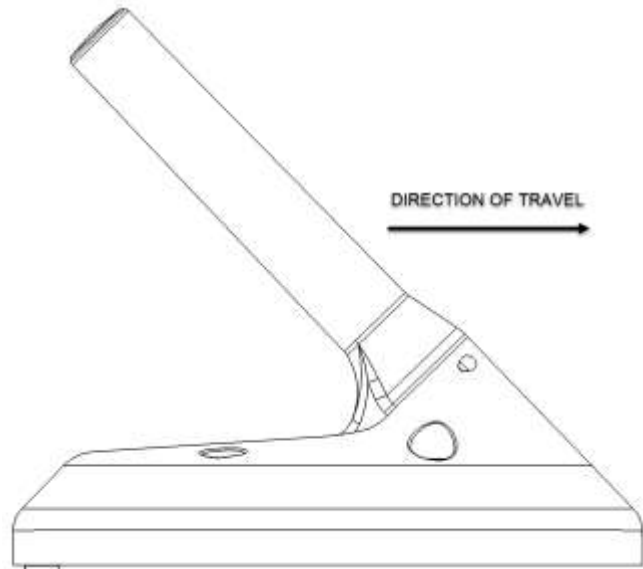

Remove the vehicles passenger compartment roof liner and expose the underside of the roof. Use care when disconnecting electronics such as overhead lights and securing clips.

Verify the area is clear of vehicle structural elements or electronics in the area immediately below the desired VTU-20 installation point.

Use masking tape to cover an area 4 inches by 6 inches on the exterior of the roof at the desired installation location.

Using the hole pattern in the drawing below and four #8 flat-head screws of the appropriate length to fasten VTU-20 to the vehicle, mark the location of the four bolt penetrations and that of the cable opening. Ensure proper alignment of the unit to the direction of travel.

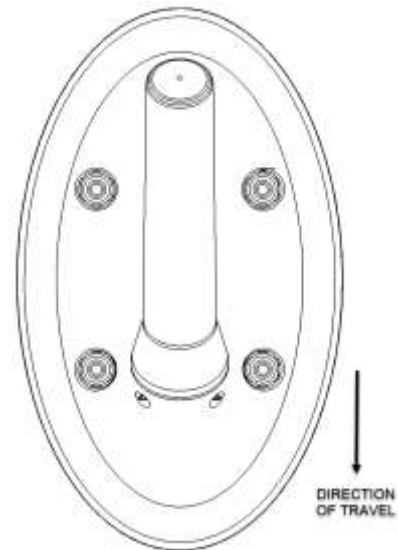

Use appropriate power tools to create penetrations through the vehicle roof for the four mounting bolts and cable entry. Install an appropriate grommet to prevent fraying wires on vehicle roof cable entry.

Remove protective tape from the roof of the vehicle, exposing the openings. Remove all traces of glue and dust from the roof and allow to dry before continuing to next step.

Place a bead of silicone sealant around the base of the unit, ensuring that a complete ring of silicone is made on the bottom of the unit.

Pass the units wiring harness through the center opening and position the unit to align the four mounting bolts to the four bolt openings on the roof.

Lower the unit to the roof evenly ensuring that an even seal is made between the VTU-20 unit and the roof of the car with silicone between them.

Tighten the enclosed bolts and washers from the underside of the vehicle roof to a force of 15 Nm.

Apply a thin bead of silicone around the entire base of unit and the roof and smooth with a slightly damp finger to remove excess.

To allow for proper curing of silicone-based sealants. Installation should be performed when weather conditions will remain free of rain, fog or condensation for a period of 24 hours. Failure to provide for proper curing

of the silicone, may result in an improper seal of the area and leaks may occur in the passenger compartment.

Place electrical cable in most appropriate and convenient manner from the roof penetration to the In-Cab Controller and secure with plastic or metal tie wraps to minimize rattles during operation.

The cable is then attached to the In-Cab Controller, per the guidelines in Section 7.4 “Connection to the Vehicle Electrical System”.

For seasonal installations, the VTU-20 EE Mounting Plate Set is available to block off the roof hole when the VTU-20 EE is seasonally or otherwise removed from the vehicle.

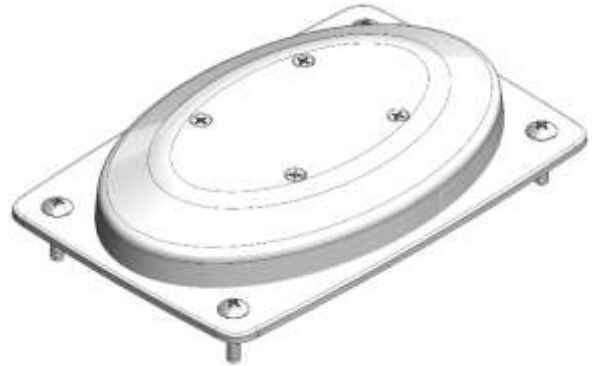

7.3.2 Magnetic Mounting (Optional)

VTU-20 comes with strong rare earth magnetic mounts designed specifically to hold the unit in place at speeds up to 100 mph. This ensures that the transmitter may remain installed during normal airfield operations or when the vehicle is operating on public motorways.

Per FAA-E-3032, the Exterior Enclosure should be installed on the “exterior top” of the vehicle. To mount the transmitter, ensure that roof of the vehicle is made of ferrous metal; magnetic mounts will not attach with sufficient force to fiber glass or aluminum roofs. In addition, before placing the unit on the roof, ensure that the area is clean of dust, debris or rust. To ensure proper contact with the roof, the area of the roof should present a flat, uniform surface. Areas with ridges and irregular contours should be avoided. Application of an interface material with a high coefficient of friction between the magnets and the vehicle roof is recommended.

To minimize unnecessary wind loading of the unit, align the unit to the front of the vehicle or the primary direction of travel. In addition, to ensure GPS accuracy and minimize time to position lock, the unit should have a clear line of sight to the sky. To mitigate reflections or blocking of 978 MHz transmissions, the unit should be a minimum of 6 inches from other roof mounted equipment such as warning lights, and 24 inches from other radio frequency emitting antennas.

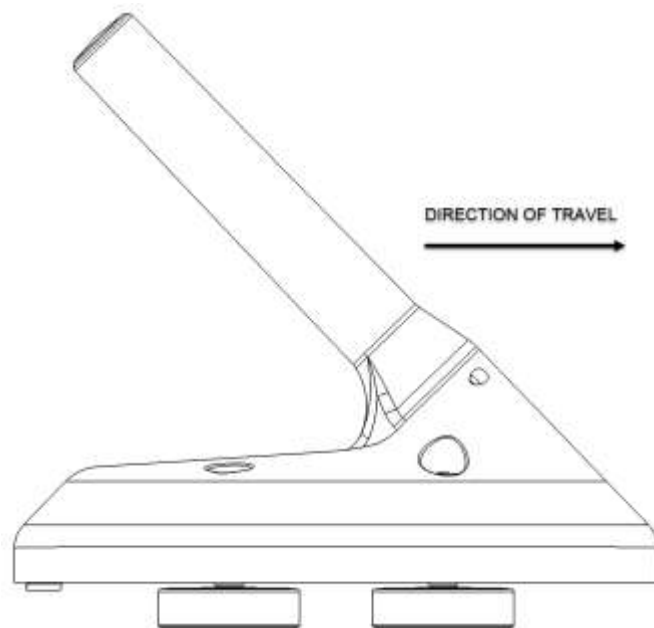

The power cable from unit will protrude from the bottom of the unit and the magnetic mounts provide sufficient clearance for the cable. The area where the cable makes entry into the unit has been weatherproofed to ensure compliance with IP67 moisture and dust penetration standards.

uAvionix recommends the use of a cable guard to protect the cable as it enters the passenger compartment through the weather stripping of the door or window. Contact your specific vehicle manufacturer/dealer for recommendations designed for your make and model.

The cable is then attached to the In-Cab Controller, per the guidelines in Section 7.4 “Connection to the Vehicle Electrical System”.

7.3.3 In-Cab Controller Mounting

The In-Cab Controller is a required component for all installations. It provides status indication and ON/OFF switching, stores geofence data, and regulates power to the Exterior Enclosure. It should be mounted in the vehicle cab within view of the operator.

7.4 Connection to the Vehicle Electrical System

The In-Cab Controller shall be connected to the vehicle power system and to the Exterior Enclosure via the supplied wiring harness, modified as

necessary for length of installation. A 5-amp fused power supply cable is recommended.

The external sheath of the supplied cable is tough, shear-resistant and resistant to mineral oils and abrasion. However, additional wire sheathing or rubber grommets may be required near locations where sheet metal or highly abrasive surfaces could wear through the VTU-20's wiring harness, for example the vehicle firewall.



ABSOLUTE MAXIMUM DC VOLTAGE GREATER THAN 36 V_{dc} WILL CAUSE PERMANENT DAMAGE TO THE EQUIPMENT

In-Cab Controller:

Pin	Function
1	GND (from Vehicle Ground)
2	V _{in} (from 12/24V Vehicle Power)
3	V _{prot} (protected power out to Exterior Enclosure)
4	GND (to Exterior Enclosure)
5	Data Tx (to Exterior Enclosure orange)
6	Data Rx (to Exterior Enclosure brown)

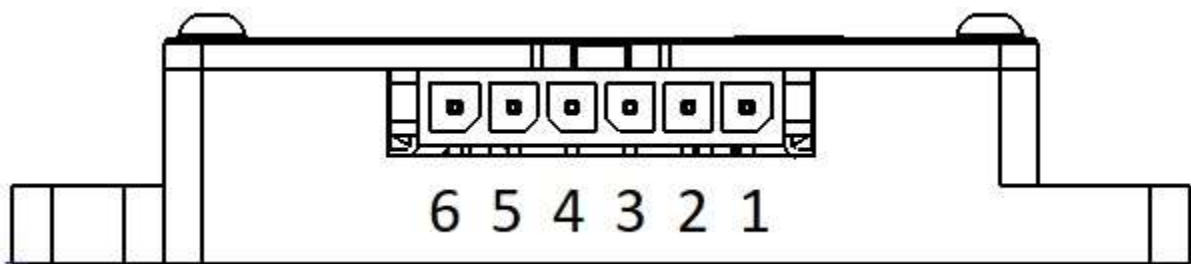

Figure 7-1 In-Cab Controller Pin Out Diagram

Exterior Enclosure:

Color	Function
Orange	Data Rx (to In-Cab Controller pin 5)
Brown	Data Tx (to In-Cab Controller pin 6)
Red	V _{prot} (protected power in from In-Cab Controller pin 3)
Black	GND (to In-Cab Controller pin 4)

During the installation, it is necessary to ensure the bend radius of the supplied cable is greater than 22mm.

Ensure that power to the In-Cab Controller is wired to power as appropriate for the application. It is important to know what type of power is supplied (accessory switched or always on) to understand when the device will be powered and broadcasting.

7.5 Routine Inspection

VTU-20 system should be routinely inspected for abnormal wear on the enclosures. Additionally, the In-Cab Controller LEDs should be routinely inspected for proper function.

8 Squitter Maps

VTU-20 can intelligently transmit when traveling in sensitive areas and automatically stop transmitting in low-risk areas using a squitter map. A squitter map is a KML file containing both transmit inclusion and exclusion zones. VTU-20 will transmit when the device is located in an inclusion zone and cease operation when it is outside the inclusion zone or when it is located inside an exclusion zone.

A valid squitter map must contain a single closed geofence or polygon labeled as Inclusion Zone. Additional closed shapes can be placed inside the inclusion zone and labeled as an Exclusion Zone. Subsequent zones should be named Exclusion Zone 01, Exclusion Zone 02, etc.

Approved squitter maps should be obtained from the FAA, as detailed in FAA/AC 150/5220-26.

A screenshot of an example is shown below.



The yellow polygon above is an example inclusion zone and the red polygon represents an exclusion zone.

9 Configuration

Configuration of the VTU-20 is accomplished using the uAvionix provided Windows application (uAvionix VTU-20 Installer). The tool may be obtained directly from uAvionix on request.

The In-Cab Controller (ICC) serves as the device personality module, holding all configuration parameters including ICAO, Call Sign, Emitter Category, Vehicle Length, Vehicle Width, GPS Antenna Lateral Offset and GPS Antenna Longitudinal offset. It also contains the FAA Squitter Map (KML), selected from an approved set of airport maps.

No direct configuration of the Exterior Enclosure (EE) is required.

9.1 Device Configuration

To configure the device parameters, follow the steps below:

1. Connect the PC's RS-232 port (commonly supplied by a USB to RS-232 Adapter) to the ICC unit. Refer to Figure 7-1 or use optional configuration harness UAV-1002582-001.
2. Apply DC power (12V recommended) to the ICC unit. Ensure ICC switch is powered on. LED activity on the ICC will indicate power is

enabled. Refer to Figure 7-1 or use optional configuration harness UAV-1002582-001.

3. Start the uAvionix Configuration Application and select the appropriate COM port for the RS-232 adapter. You may need to use Windows Device Manager to determine the correct port number.
4. In the ICAO field, enter the previously obtained ICAO number for the device being configured. Note, this ICAO field should be unique for each VTU-20 unit and should be entered in hexadecimal format.

Example: "A8AF9F".

5. In the Call Sign field, enter the previously obtained Call Sign. This is referred to as "Vehicle ID" FAA-E-3032 or "radio call sign" in AC 150/5220-26.

Example below, "UT30".

6. In the Emitter Category dropdown box, select either Surface Vehicle Service or Surface Vehicle Emergency depending on the host vehicle.

Example, VTU-20 on a snow plow → Surface Vehicle Service

Example, VTU-20 on a fire truck → Surface Vehicle Emergency

7. Select the Vehicle Length dropdown box and choose the appropriate length in meters for the host vehicle.
8. Select the Vehicle Width dropdown box and choose the appropriate width in meters for the host vehicle.
9. Select the Lateral GPS Antenna Offset dropdown box and choose the lateral distance in meters the unit is installed relative to the centerline of the vehicle.
10. Select the Longitudinal GPS Antenna Offset dropdown box and choose the relative distance from the nose/front bumper of the vehicle to the installed unit.

11. Click the green “Update” button to send the configuration parameters to the VTU-20 EE.



12. Ensure that the following confirmation dialog appears.

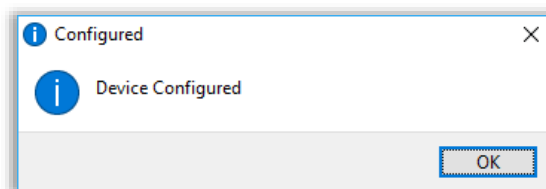

9.2 Squitter Map Installation

To install a squitter map, follow the steps below:

1. Ensure the device is connected to the PC and powered on. See steps 1-3 of Section 9.1.
2. Under the Geofence section located near the bottom of the window, click “Choose File” to select the desired airport KML file.



Caution: Only FAA approved maps should be uploaded to the ICC.

uAvionix VTU-20 Installer (1.1.0)

echo
CONNECTED TO DEVICE

Configuration

COM Port:
COM7

Transmitter Configuration

ICAO Number (hex):
ABAF9F

Call Sign:
MRPLOW

Emitter Category:
Surface Vehicle - Ser

Vehicle Length (meters):
L < 15

Vehicle Width (meters):
W < 23

GPS Antenna Offset, Lateral from centerline (meters):
0

GPS Antenna Offset, Longitudinal aft from front of vehicle (meters):
2

Update

Geofence

Geofence KML File:
Choose File | No file chosen

Update Geofence Reset Geofence

3. Verify the configuration application reports “Opened file successfully” as shown below. If an error is generated during this step, then the KML file is invalid. Please report the error and do not proceed with provisioning.



4. Click the “Update Geofence” button located at the bottom left of the window. The status indicator will change to “Uploading...” during the update process.

5. Verify the configuration application reports “Geofence uploaded successfully”. In cases where the Geofence upload was unsuccessful, the application will report “Failed to upload geofence data”.

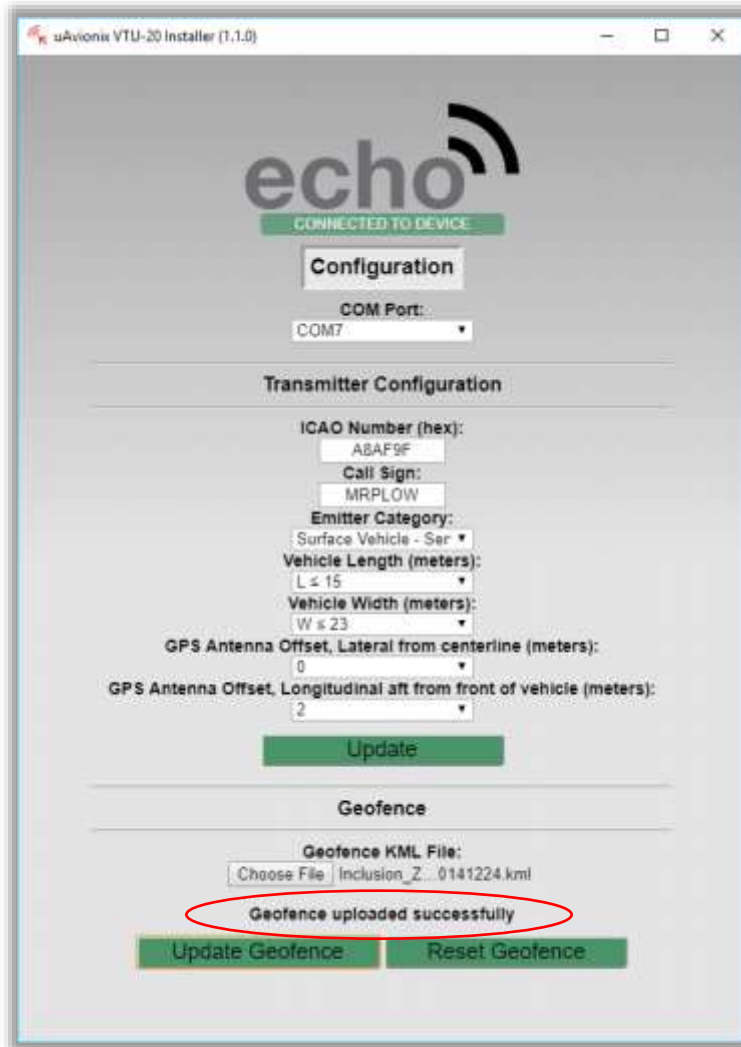

9.3 Squitter Map Removal

To reset and remove the squitter map from the device, follow the steps below:

1. Ensure the device is connected to the PC and powered on. See steps 1-3 of Section 9.1.
2. Under the Geofence section located near the bottom of the window, click “Reset Geofence”.

3. A confirmation message should appear indicating “Geofence successfully reset” as shown below.



10 Normal Operation

When properly installed, configured and powered, the VTU-20 will function without user interaction. Geofence data will be evaluated, and when in an inclusion zone, the device will transmit. When outside of an inclusion zone, or in an exclusion zone, the device will not transmit.

The following status indications are available on the In-Cab Controller.

ICC LED	Off	Blink (1Hz)	On
UAT Status (Green)	Out of transmission area	Unused	In transmission area
GPS/Power Status (Green)	VTU-20 off	No GPS 3D fix	VTU-20 on
Fault (Red)	No failures	Device or configuration failure	Self-test in progress / self-test failure

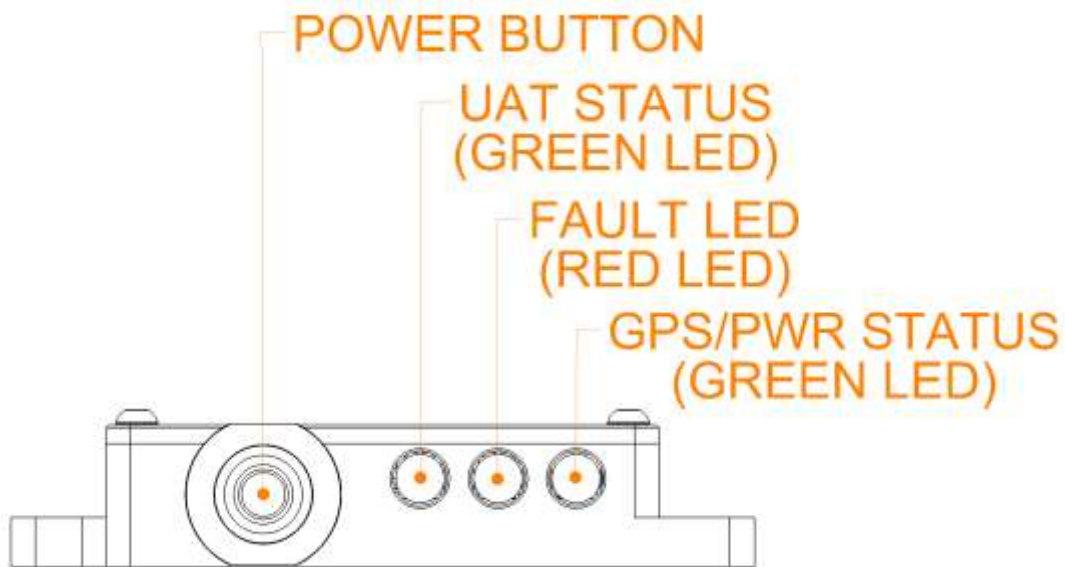

11 Warranty Conditions



Warning!

Device parameters and geofence data appropriate for the operating airport must be configured prior to use.



Warning!

The user is not allowed to make any modifications to the equipment.



Caution!

Use the equipment only in an intended manner described in this User and Installation Guide.



Caution!

The manufacturer shall not be responsible for any damages caused by an incorrect installation on the vehicle and/or an unqualified installation in the vehicle electrical system.

The manufacturer shall not be responsible for any damages caused by equipment use not consistent with instructions in this User and Installation Guide.

The manufacturer shall not be responsible for any damages caused by the equipment falling from the vehicle, on the vehicle or in its environment.

12 Environmental Qualification Forms

Nomenclature	VTU-20	
Part No	UAV-1001253-001	
Manufacturer	uAvionix Corporation	
Address	300 Pine Needle Lane, Bigfork, MT 59911	
Conditions	SAE/J1455 Section	Description of Conducted Tests
Temperature	4.1	5d Top
Low temperature ground survival		-55°C
Low Temperature Short-Time Operating		-45°C
Low Temperature Operating		-45°C
High Temperature Operating		+70°C
High Temperature Short-Time Operating		+70°C
High Temperature Ground Survival		+85°C
Humidity	4.2	
Salt Spray	4.3	96 Hour Salt Fog (NaCL)
Steam Cleaning and Pressure Washing	4.5	
Altitude	4.9	
Mechanical Vibration	4.10	Category 3 – 3-axis with resonance sweep
Mechanical Shock	4.11	3-axis 20G, 15G and 10G tests with pulse durations of 1.5, 1.5 and 3ms
Combined Environments	4.12	
Transient, Noise and Electrostatic Characteristics for 12 and 24 V	4.13.2	
Electromagnetic Compatibility	4.13.3	