



AV-30-C

Instructions for Continued Airworthiness



© 2020 - 2022 uAvionix Corporation. All rights reserved.

uAvionix Corporation
Bigfork, MT

www.uavionix.com
support@uavionix.com

Except as expressly provided herein, no part of this guide may be reproduced, transmitted, disseminated, downloaded, or stored in any storage medium, for any purpose without the express written permission of uAvionix. uAvionix grants permissions to download a single copy of this guide onto an electronic storage medium to be viewed for personal use, provided that the complete text of this copyright notice is retained. Unauthorized commercial distribution of this manual or any revision hereto is strictly prohibited.

uAvionix® and Ping® are registered trademarks of uAvionix Corporation and may not be used without express permission of uAvionix.

AV-30, AV-30-E, and AV-30-C, BeaconX, tailBeaconX, and skyBeaconX are trademarks of uAvionix Corporation and may not be used without express permission of uAvionix.

Patents www.uavionix.com/patents

1 Revision History

Revision	Date	Comments
A	4/24/2020	Initial release
B	12/6/2021	Update battery check Update System Interconnect drawing Editorial updates
C	9/29/2022	Update nominal battery operation to 1 hour (was incorrectly described as 2 hours)



2 Warnings / Disclaimers

All device operational procedures must be learned on the ground.

uAvionix is not liable for damages arising from the use or misuse of this product.

This equipment is classified by the United States Department of Commerce's Bureau of Industry and Security (BIS) as Export Control Classification Number (ECCN) 7A994.

These items are controlled by the U.S. Government and authorized for export only to the country of ultimate destination for use by the ultimate consignee or end-user(s) herein identified. They may not be resold, transferred, or otherwise disposed of, to any other country or to any person other than the authorized ultimate consignee or end-user(s), either in their original form or after being incorporated into other items, without first obtaining approval from the U.S. government or as otherwise authorized by U.S. law and regulations.

3 Limited Warranty

uAvionix products are warranted to be free from defects in material and workmanship for two years from the installation of the AV-30-C on the aircraft. For the duration of the warranty period, uAvionix, at its sole option, will repair or replace any product which fails in normal use. Such repairs or replacement will be made at no charge to the customer for parts or labor, provided that the customer shall be responsible for any transportation cost.

Restrictions: This warranty does not apply to cosmetic damage, consumable parts, damage caused by accident, abuse, misuse, water, fire or flood, theft, damage caused by unauthorized servicing, or product that has been modified or altered.

Disclaimer of Warranty: IN NO EVENT, SHALL UAVIONIX BE LIABLE FOR ANY INCIDENTAL, SPECIAL, INDIRECT OR CONSEQUENTIAL DAMAGES, WHETHER RESULTING FROM THE USE, MISUSE OR INABILITY TO USE THE PRODUCT OR FROM DEFECTS IN THE PRODUCT. SOME STATES DO NOT ALLOW THE EXCLUSION OF INCIDENTAL OR CONSEQUENTIAL DAMAGES, SO THE ABOVE LIMITATIONS MAY NOT APPLY TO YOU.

Warranty Service: Warranty repair service shall be provided directly by uAvionix. Proof of purchase for the product from uAvionix or authorized reseller is required to obtain and better expedite warrant service.

Please email or call uAvionix support with a description of the problem you are experiencing. Also, please provide the model, serial number, shipping address and a daytime contact number.

You will be promptly contacted with further troubleshooting steps or return instructions. It is recommended to use a shipping method with tracking and insurance.

4 Table of Contents

1	Revision History.....	3
2	Warnings / Disclaimers.....	4
3	Limited Warranty	5
4	Table of Contents	6
5	Introduction.....	8
5.1	Publications	8
5.2	Revision and Distribution	8
6	System Description.....	9
6.1	System Functions	11
6.2	System Interconnects	12
7	Instructions for Continued Airworthiness.....	13
7.1	Airworthiness Limitations	13
7.2	Test and Service Procedures.....	13
7.3	Installation, Removal and Trouble Shooting Procedures.....	13
7.4	Test and Inspection Schedules	14
7.5	On-Condition Servicing.....	14
7.6	Display Backlight Useful Life.....	14
7.7	Special Tools	14
7.8	Visual Inspection Procedure	15
7.9	Altimeter Test and Calibration Procedure	16
7.9.1	Display Mode and Baro Setting.....	16
7.9.2	Install Menu Activation	17
7.9.3	Accessing Install Menu.....	17
7.9.4	Applicable Install Menu Settings.....	18
7.9.5	Altimeter Trimming	18
7.10	Battery Test and Replacement Procedure	19
7.10.1	Manual Load Test	19
7.10.2	Battery Replacement.....	20
8	Post-Installation Test Procedures	22

9 Troubleshooting.....22

10 Return to Service Procedure.....22

11 Maintenance Records.....22

12 Support.....22

13 Appendix A – Installation Record.....23

5 Introduction

This document provides Instructions for Continued Airworthiness (ICA) and Maintenance Manual (MM) for the AV-30-C. This document satisfies the requirements for continued airworthiness as defined by 14 CFR 23.1529. Information in this document is required to maintain the continued airworthiness of the AV-30-C.

5.1 Publications

When performing AV-30-C system maintenance it is required the following documents are available.

Part Number	uAvionix Document
UAV-1003947-001	AV-30-C Installation Manual
UAV-1003946-001	AV-30-C Pilots Guide
UAV-1004044-001	AV-30-C Flight Manual Supplement

Owner/operators may obtain these documents at www.uavionix.com or by contacting a uAvionix dealer.

5.2 Revision and Distribution

This document is required for maintaining the continued airworthiness of the aircraft. When this document is revised, every page will be revised to indicate current revision level.

Owner/operators may obtain the latest revision of this document at www.uavionix.com or by contacting a uAvionix dealer. They may also register for updates and support at www.uavionix.com.

6 System Description

The uAvionix AV-30-C is a fully digital multi-mode instrument that mounts in the legacy 3 1/8" round instrument panel. It can be field configured as either an Attitude Indicator (AI) or a Directional Gyro (DG) indicator. It is fully self-contained with dual-precision inertial and pressure sensors and allows for a wide variety of pilot customization. Transponder control is available in both AI and DG modes.



When configured as an AI, primary attitude and slip are always displayed. The unused portions of the display area can be customized by the pilot to show a variety of textual and graphical data overlay fields. Three pages may be customized by the pilot while a fourth page presents a fully decluttered view of attitude and slip, while optionally presenting transponder controls.

When configured as a Directional Gyro (DG), direction of flight information is presented. The flight direction can be configured to be presented as a non-slaved heading or inertially stabilized GPS track when connected to an external GPS navigator. Multiple display presentations, including compass rose, GPS HSI, and GPS ARC views can be selected by the pilot. The unused portions of the display area can similarly be configured for a variety of textual data overlays.

In all operating modes, the pilot may select from multiple visual styles which are intended to improve visual compatibility with legacy aircraft instrumentation and preserve the look-and-feel of older aircraft applications.

A wide variety of supplemental functions, including audio alerting, derived angle of attack presentation, g-load display, and more are provided. An internal, rechargeable battery allows for operation for a nominal 1 hour in the event of aircraft power loss in flight and 30 minutes minimum under all temperature conditions.

See *AV-30-C Pilots Guide UAV-1003946-001* for additional details.

6.1 System Functions

Primary Functions:

- Primary Attitude (AI Mode)
- Primary Slip (AI Mode)
- Primary Direction of Flight Indication (DG Mode)

Supplemental Functions:

- Indicated Airspeed
- Altitude
- V-Speeds
- Angle Of Attack
- Vertical Trend
- Vertical Speed
- Set Altitude
- Heading
- Bus Voltage
- G Load
- Outside Air Temp
- True Airspeed
- Density Altitude
- GPS Navigator / Waypoint Data
- GPS Navigator Nav Data
- GPS Navigator Route Line
- Heading Bug
- Transponder Control (AI / DG Mode)

Audio and Visual Alerting Functions:

- AoA Alerting
- G Limit Alerting
- Excessive Roll Alerting

Misc. Functions:

- Internal Battery Operation
- Auto / Manual Brightness

6.2 System Interconnects

The following section describes each of the AV-30-C system interconnects. Interfaces indicated as optional are not required in any specific installation but will limit availability of some supplemental data display if not connected.

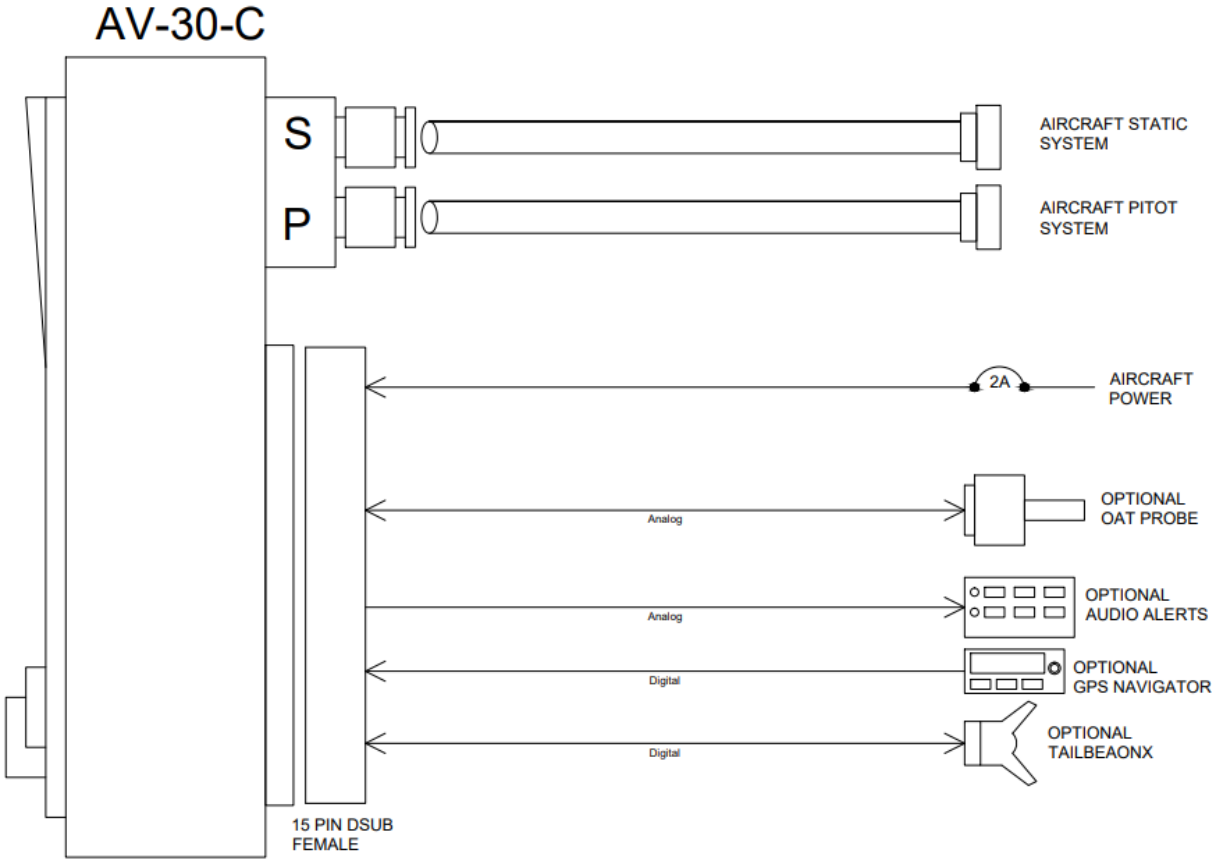

All connections are provided on the single 15-Pin D-sub connector and the two pneumatic fittings.

7 Instructions for Continued Airworthiness

This section provides Instructions for Continued Airworthiness of the AV-30-C system as installed under AML-STC #SA00410BO and satisfies the requirements for continued airworthiness as defined by 14 CFR Part 23.1529 and Part 23 Appendix G (Amendment 61).

7.1 Airworthiness Limitations

The Airworthiness Limitations section is FAA-approved and specifies maintenance required under 14 CFR Part 43.16 and 14 CFR Part 91.403 of the Federal Aviation Regulations unless an alternative program has been FAA-approved.

There are no new (or additional) airworthiness limitations associated with this equipment and/or installation.

No component-level overhaul is required.

7.2 Test and Service Procedures

Utilize *Section 7.8 - Visual Inspection Procedure* of this document to perform visual inspections when required.

Utilize *Section 7.9.5 - Altimeter Test and Calibration Procedure* of this document to perform altimeter trimming when required.

Utilize *Section 7.10 - Battery Test and Replacement Procedure* of this document to test and replace the battery when required.

The Altitude Trim procedure only applies when the AV-30-C is configured as an Attitude Indicator or transponder control head. In other cases, altitude is not displayed and therefore trimming is not applicable.

7.3 Installation, Removal and Trouble Shooting Procedures

For other non-related instructions including removal, installation and troubleshooting procedures of the unit, reference *AV-30-C Installation Manual*.

7.4 Test and Inspection Schedules

For VFR operations (Recommended, not required):

- Perform visual inspection every 12 calendar months.
- Perform altimeter calibration every 24 calendar months.
- Perform battery test every 24 calendar months.

For IFR operations (Required):

- Perform visual inspection every 12 calendar months.
- Perform altimeter calibration every 24 calendar months.
- Perform battery test every 24 calendar months.
- Replace battery every 5 years.

7.5 On-Condition Servicing

On Condition replacement and/or servicing may be required when conditions, symptoms, and/or servicing should take place only after the system is troubleshot based on guidance provided in this manual and per common avionics maintenance practices.

7.6 Display Backlight Useful Life

The display backlight is rated for 50,000 hours, however degradation of the display intensity is normal and will occur over time. The useful life is dependent on operational conditions. Backlight replacement may be required based on pilot discretion - the unit must be returned to the factory for this service.

7.7 Special Tools

The following tools are needed to perform maintenance tasks.

- Ground power source (capable of supplying sufficient power to the aircraft systems and avionics)
- Air Data Test Set
- Timer or stop-watch for battery capacity test

7.8 Visual Inspection Procedure

Perform a visual inspection as detailed in this section.

- Inspect the unit and verify it is securely mounted.
- Inspect the unit fasteners and verify they are properly torqued (6 +/- 1 Inch LBS) and show no wear or damage.
- Inspect unit support structure and verify it is in good condition and its integrity is not compromised.
- Inspect the condition of the wiring.
- Verify that all wiring and cables are securely fastened.
- Verify that the harness shows no signs of cracking, chafing, abrasion, melting, or any other form of damage.
- Inspect unit connector and ground strap for corrosion, evidence of moisture, or other defects.
- Inspect pneumatic connections and repair or replace those parts that are defective (e.g., broken “B” nuts, cracked flare sleeves, deteriorated flexible tubing, bad valves). Purge the system, if necessary, to remove foreign matter that may have accumulated in the tubing.
- Inspect display screen to ensure it is clean and free of debris. If cleaning is required, utilize a soft cloth and glass cleaner. Do not clean with alcohol-based solvents.
- Caution—Be sure to remove all pitot pressure and static air connections to every instrument before purging the system tubing.

7.9 Altimeter Test and Calibration Procedure

Altimeter calibration must be done in accordance with *14 CFR Part 91.411 Altimeter system and altitude reporting equipment tests and inspections*.

User interface control and operation required to enter and navigate the maintenance mode is provided here.

For a full description of the user interface, refer to document *AV-30-C Pilots Guide*.

7.9.1 Display Mode and Baro Setting

For these purposes, the user interface must be configured to show altitude. If altitude is not configured for display, refer to *AV-30-C Pilots Guide* for procedures to configure altitude to be shown.

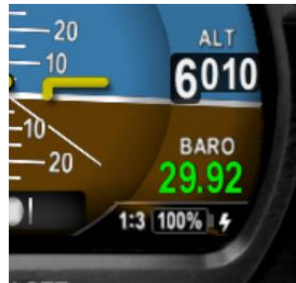

The baro setting must be set to 29.92 for these tests.

7.9.2 Install Menu Activation

The install menu allows for configuration changes and adjustments that are not normally pilot accessible. To access the Install Menu, ensure the unit is turned off. Press and hold the main control knob while power is applied.



Push and Hold While Applying Power

Keep the knob pressed until the startup logo is shown. The Install Menu will now be enabled for access.

7.9.3 Accessing Install Menu

To access the Install menu, press the Menu button until the INSTALL menu is shown:

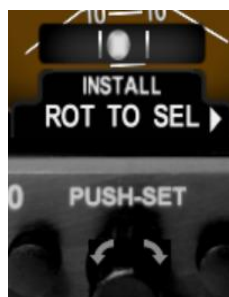
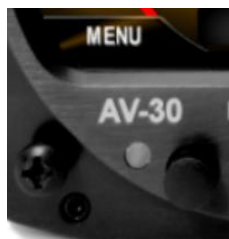

Rotating the knob left and right will access the various parameters that may be configured.

Pressing the knob when the desired field is shown will allow the associated setting to be edited. The parameter and associated setting will be shown in magenta while the editing mode is active:



Rotating the knob left and right changes the indicated value. After adjustment, pressing the knob again will disable the editing mode but the Install Menu will remain active.

Pressing DONE will exit the Install Menu.

7.9.4 Applicable Install Menu Settings

The Install Menu options and settings allow for various parameters to be set and calibrated. Parameter settings that are not associated with ongoing maintenance (operational modes, port settings, etc.) must not be modified and maintained in accordance with the setting definitions within *AV-30-C Installation Manual*.

7.9.5 Altimeter Trimming

Connect the pitot static test set and follow applicable calibration procedures in accordance with *14 CFR Part 91.411*. Trim the indicated altitude as required.

Once complete, exit the Install Menu and turn power off. The altitude trim setting will be stored in internal memory.

7.10 Battery Test and Replacement Procedure

7.10.1 Manual Load Test

The following procedure is utilized to ensure the AV-30-C internal battery meets minimum capacity for emergency operation.

A timer or stopwatch is required for this test procedure. This test is to be performed in standard ambient conditions ranging from 40°F to 90°F.

1. Ensure the battery is fully charged (100% status and with no charging indicator shown).
2. If battery is not fully charged, connect aircraft to ground-power, turn the instrument on and allow full charge levels to be obtained.
3. Set manual mode for display backlight and set to maximum brightness.
4. Remove power to the unit by pulling the corresponding circuit breaker. When power-down screen is displayed, press any button to abort the shutdown sequence.
5. Start the timer and ensure the unit remains operating for 1 hour without shutting down.
6. If unit shuts-down occurs prior to the required time duration, repeat the procedure ensuring full charge is obtained prior to executing the test. If failure occurs on the second test cycle, replacement of the battery is required.
7. To shut unit down when operating on battery, press both left and right buttons together.

7.10.2 Battery Replacement

The battery pack is located on the rear of the unit and housed in a removable battery cover assembly.

The battery pack is wrapped in a thermal insulation blanket that assists in maintaining internal thermal energy when operating at cold temperatures. The existing thermal blanket is re-used.

Battery replacement consists of removing the battery cover, removal and unwrapping of the old battery pack, re-wrapping the new battery pack and re-assembly.

Ensure unit power is removed and unit is not operating under battery power for this procedure.

Details steps as follows:

1. Remove the two battery cover hold-down screws.

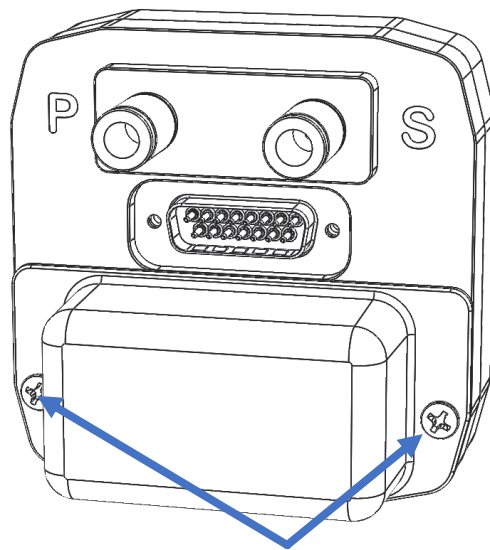

Battery Cover Hold-Down Screws

2. Remove the wrapped battery pack and pull gently on the battery wires close to the connector to disconnect the battery from the unit.

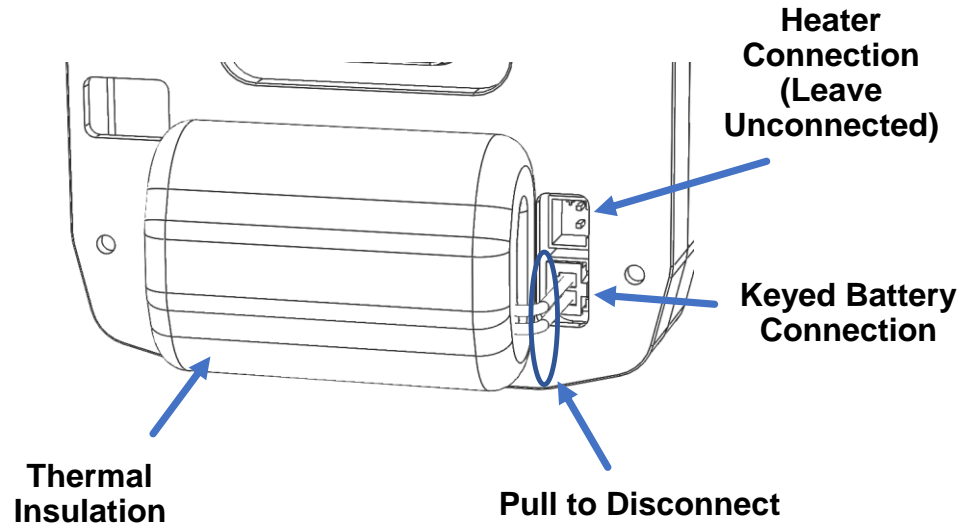

3. Un-wrap the old battery pack and do not discard the thermal insulation.
4. Re-wrap the new battery pack and insert into the battery cover, leaving the battery connection wires outside of the wrapping.
5. Locate the keyed side of the battery connector and press firmly into the mating connector on the unit.
6. Tuck the battery wire into the battery cover while aligning the battery cover to the rear of the unit – ensure the battery wires are not caught or compressed between the battery cover and the unit.
7. Replace the two battery cover hold-down screws and tighten firmly.
8. Dispose of the old battery pack in accordance with local regulatory requirements regarding Li-ion battery disposal or recycling.

8 Post-Installation Test Procedures

Refer to *AV-30-C Installation Manual* for Post-Installation Checks to be performed after removal and re-installation.

9 Troubleshooting

Refer to *AV-30-C Installation Manual* for trouble shooting procedures.

10 Return to Service Procedure

After removing and re-installing or replacing the AV-30-C, perform the setup and configuration procedures in the *AV-30-C Installation Manual*.

11 Maintenance Records

After conducting the test and service procedures as defined in this document, the aircraft may be returned to service.

Record the following information in the appropriate aircraft maintenance logs.

- Part number and serial number of the unit that was replaced or re-installed.
- Any other applicable information related to the maintenance work performed on the aircraft.

Appendix A includes an installation record that should be completed and updated as appropriate with every maintenance action.

12 Support

For additional questions or support please visit:

<http://www.uavionix.com/support/>

13 Appendix A – Installation Record

A copy of this appendix should be used to record installation information and should be kept in the aircraft permanent records.



A copy of this form must be submitted by visiting:

<https://uavionix.com/logbook/>

AV-30-C Installation and Configuration Log

Date:	By:
Aircraft Information	
Make:	Model:
Serial Number:	Registration Number:
AV-30-C Information	
Serial Number(s):	Configuration (AI/DG):
Customer Information	
Name:	
Email:	
Telephone:	
Address:	